

Las longitudes de **L.C. = Lado Corto** y **L.L. = Lado Largo**, corresponden a longitudes que se miden en la muelle u hoja a condición plana (sobre la superficie exterior, ó lado de tensión de la hoja)

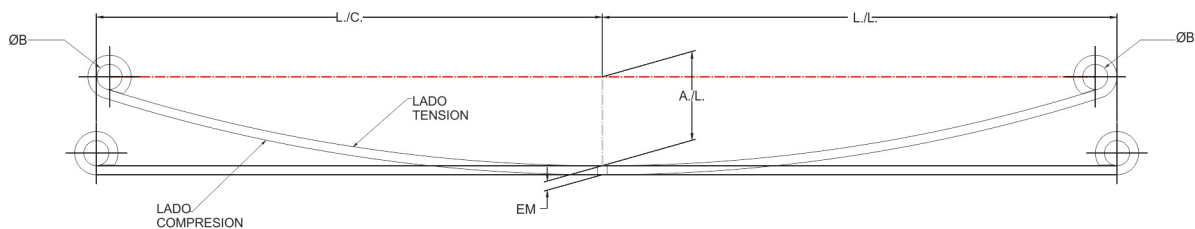

- a)** Si no es posible medirla en forma recta, se pueden tomar las medidas a la muelle formada de la misma forma que si estuviera plana, siguiendo el lado de tensión de la hoja.

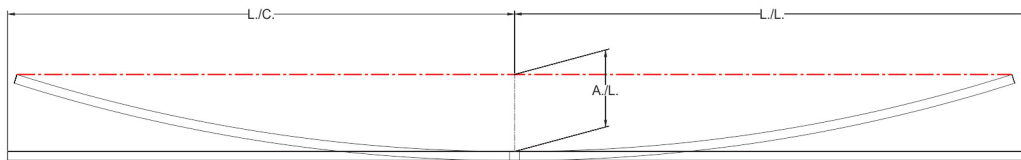

- b)** En una hoja recta (lisa), las medidas de L.C. Y L.L. se pueden tomar por cualquiera de los 2 lados, tensión o compresión.

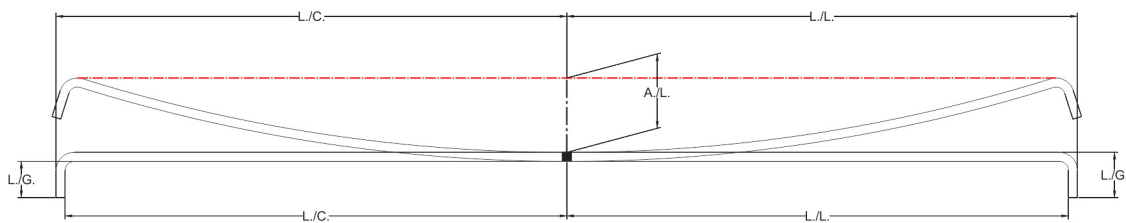

- c)** En las hojas con ganchos en extremos, las medidas de L.C. Y L.L. Asi como la longitud del gancho, se pueden tomar de extremo a extremo (por fuera, le llamamos) ó restando el espesor del material (le llamamos por dentro).

Tipos de Roleo



No.1 / NORMAL

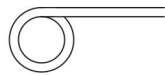

No.2 / INVERTIDO



No.3 / OVALADO



No.4 / BERLIN

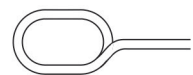

No.5 / BERLIN OVALADO

Terminación de Puntas

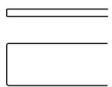

No.6

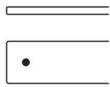

No.7

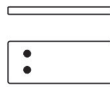

No.8

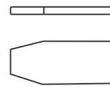

No.9

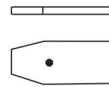

No.10

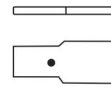

No.11

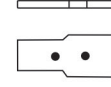

No.12



No.13

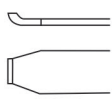

No.14

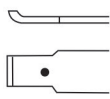

No.15

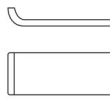

No.16

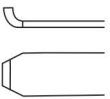

No.17

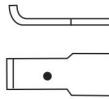

No.18

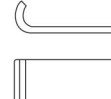

No.19

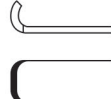

No.20

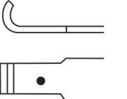

No.21

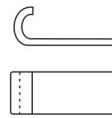

No.22

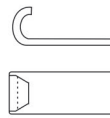

No.23

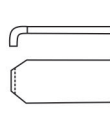

No.36

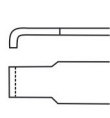

No.37

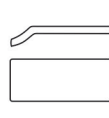

No.38

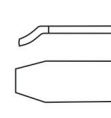

No.39

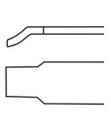

No.40

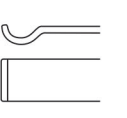

No.41

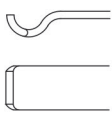

No.42

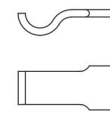

No.43

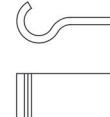

No.44

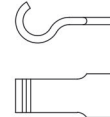

No.45

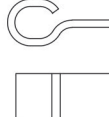

No.46

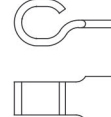

No.47

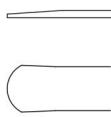

No.48

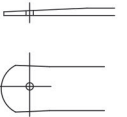

No.49

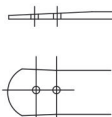

No.50

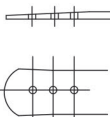

No.51

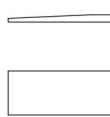

No.52

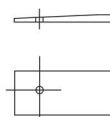

No.53

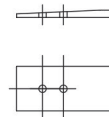

No.54

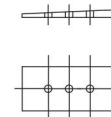

No.55

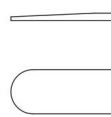

No.56

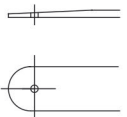

No.57

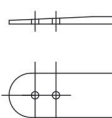

No.58

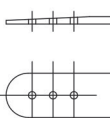

No.59

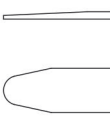

No.60

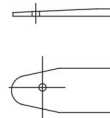

No.61

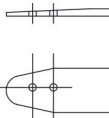

No.62

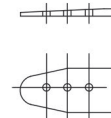

No.63

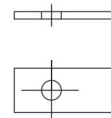

No.64

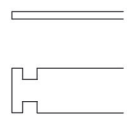

No.65

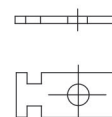

No.66

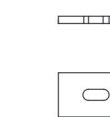

No.67



No.68



No.69



No.70

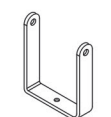

No.71

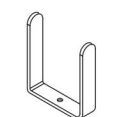

No.72

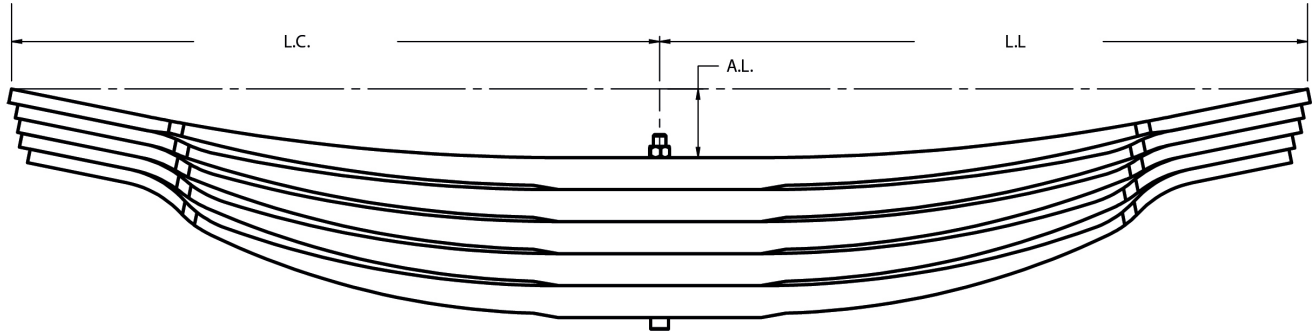

# SANDOVAL	# ORIGINAL	MODELO	ANCHO	ESPESOR	L./C.	L./L.	BRÍO	BUJE L./C.	BUJE L./L.
AS-0001	-	HD9 84.48 (Burrita Italiana)	100 mm	40 mm	32 3/8"	32 3/8"	3 3/8"	NA	NA
AS-0001-1			100 mm	40 mm	32 3/8"	32 3/8"			
AS-0001-2			100 mm	40 mm	32 3/8"	32 3/8"			
AS-0001-3			100 mm	40 mm	32 3/8"	32 3/8"			
AS-0001-4			100 mm	40 mm	32 3/8"	32 3/8"			
AS-0001-5			100 mm	40 mm	32 3/8"	32 3/8"			

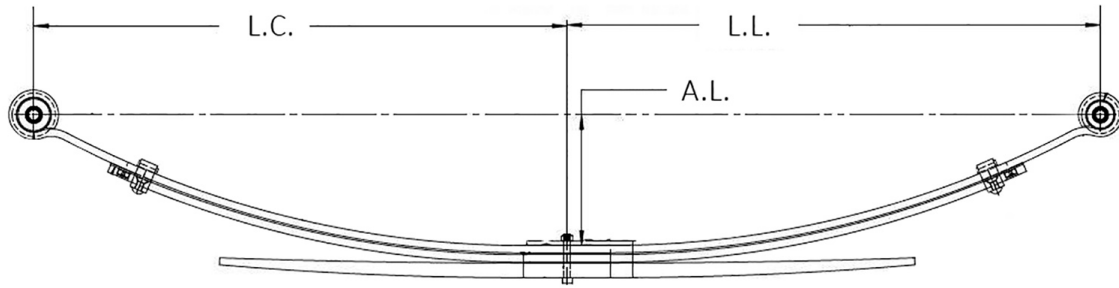

# SANDOVAL	# ORIGINAL	MODELO	ANCHO	ESPEJOR	L./C.	L./L.	BRÍO	BUJE L./C.	BUJE L./L.
22-1567-1	25976356	Camión	2 1/2"	0.447"	32"	32"	7 1/2"	RB-250CR	RB-172CR
22-1567-2				0.447"	27"	27"			
22-1567-2RD				0.447"	32"	32"			
22-1567-3				0.447"	32"	32"			

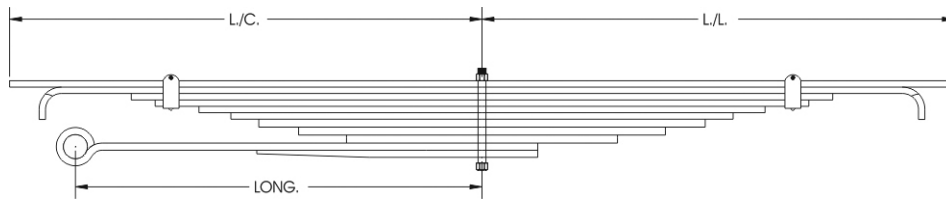

# SANDOVAL	# ORIGINAL	MODELO	ANCHO	ESPEJOR	L./C.	L./L.	BRÍO	BUJE L./C.	BUJE L./L.
23030	3818302, 2455008	Serie 40-50 Mod 63-77, Trasera	2 1/2"	0.360"	29 5/8"	29 5/8"	8 1/8"		
23030-1				0.360"	29 5/8"	29 5/8"			
23030-2				0.360"	27 5/8"	27 5/8"			
23030-3				0.360"	22"	22"			
23030-4				0.360"	21"	21"			
23030-5				0.360"	18"	18"			
23030-6				0.467"	16"	16"			
23030-7				0.467"	12 3/4"	12 3/4"			
23030-8				0.467"	9 1/2"	9 1/2"			
23030-9				0.360"	5 1/4"	5 1/4"			
23030-10				0.401"	24"	3 1/2"			
23030-11				0.401"	9 1/2"	2"			

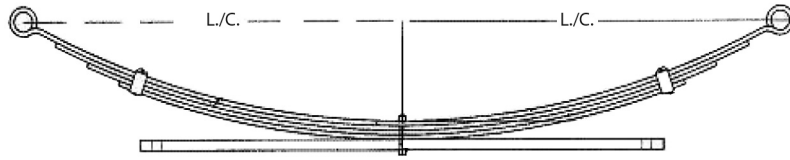

# SANDOVAL	# ORIGINAL	MODELO	ANCHO	ESPESOR	L./C.	L./L.	BRÍO	BUJE L./C.	BUJE L./L.
23032	15620357	Doble rodado 2500, Mod.92 / Trasera	2 1/2"	0.360"	32"	32"	7 1/2"		
23032-1				0.360"	32"	32"		RB-117	RB-117
23032-2				0.341"	29 1/8"	29 1/8"			
23032-2RD				0.360"	32"	32"			
23032-3				0.341"	26 1/4"	26 1/4"			
23032-3E				0.360"	27"	27"			
23032-4				0.341"	23 1/2"	23 1/2"			
23032-4E				0.360"	25"	25"			
23032-5				0.788"	21 1/4"	21 1/4"			

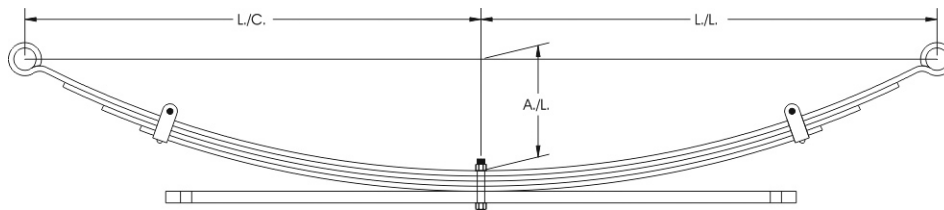

# SANDOVAL	# ORIGINAL	MODELO	ANCHO	ESPESOR	L./C.	L./L.	BRÍO	BUJE L./C.	BUJE L./L.
24032	93422799	C20 Pick Up Che- yene Mod. 91-95 / Trasera	2 1/2"	0.401"	32"	32"	7 3/4"		
24032-1				0.401"	32"	32"		RB-117	RB-117
24032-2				0.401"	29 1/8"	29 1/8"			
24032-2RD				0.401"	32"	32"			
24032-3				0.401"	26 1/4"	26 1/4"			
24032-4				0.401"	23 1/2"	23 1/2"			
24032-5				0.999"	21 1/4"	21 1/4"			

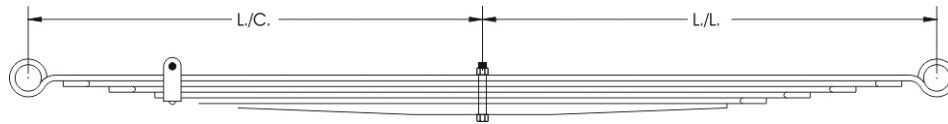

# SANDOVAL	# ORIGINAL	MODELO	ANCHO	ESPESOR	L./C.	L./L.	BRÍO	BUJE L./C.	BUJE L./L.
25026	3941764	C30 1 ½ Ton. Mod. 69-72/ Trasera	2 ½"	0.323"	26"	26"	6 1/2"		
25026-1				0.323"	26"	26"		RB-117	RB-117
25026-2				0.323"	24"	24"			
25026-2RD				0.323"	26"	26"			
25026-3				0.323"	21 3/8"	21 3/8"			
25026-3A				0.323"	22"	22"			
25026-4				0.323"	18 3/4"	18 3/4"			
25026-4A				0.323"	20"	20"			
25026-5				0.323"	16 1/4"	16 1/4"			
25026-5A				0.323"	18"	18"			
25026-6				0.625"	14"	14"			
25026-6A				0.323"	16 1/4"	16 1/4"			

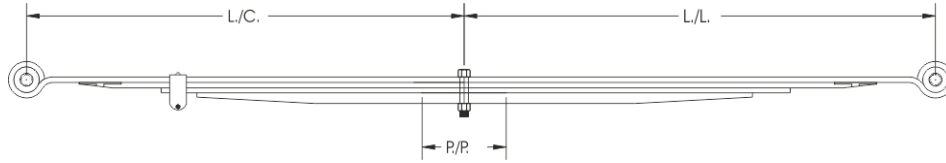

# SANDOVAL	# ORIGINAL	MODELO	ANCHO	ESPESOR	L./C.	L./L.	BRÍO	BUJE L./C.	BUJE L./L.
25026-CH1	155683339	CHEV TRUCK	2 1/2 "	0.323"	26"	28"	5 7/8"	RB-117CR	RB-117CR

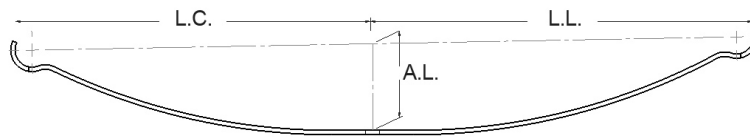

# SANDOVAL	# ORIGINAL	MODELO	ANCHO	ESPESOR	L./C.	L./L.	BRÍO	BUJE L./C.	BUJE L./L.
25026-CH2RD	155683339	Truck S10 (Refuerzo) Mod. 2002-2006 / Trasera	2 1/2 "	0.323"	26 3/16"	28 3/16"	6 3/8"		

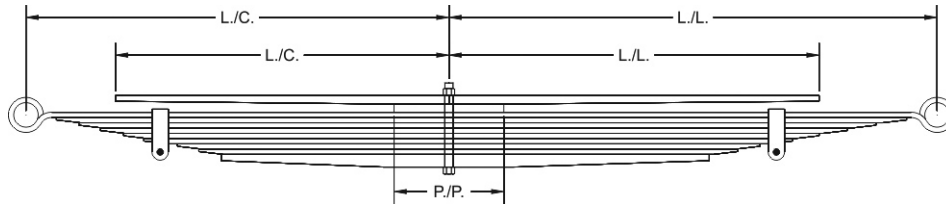

# SANDOVAL	# ORIGINAL	MODELO	ANCHO	ESPESOR	L./C.	L./L.	BRÍO	BUJE L./C.	BUJE L./L.
25030	6271320	C30 Estacas Doble Rodado Mod. 73-91 / Trasera	2 1/2"	0.323"	26"	30"	6"		
25030-1				0.323"	26"	30"		RB-136	RB-117
25030-2				0.323"	24 1/8"	28 1/8"			
25030-2RD				0.323"	26"	30"			
25030-3E				0.323"	22 3/4"	26 1/4"			
25030-4				0.323"	21 7/16"	24 1/2"			
25030-5				0.323"	20"	22 3/4"			
25030-6				0.291"	18 3/4"	21 1/8"			
25030-7				0.291"	16 11/16"	19 1/8"			
25030-8				0.291"	15 3/8"	17 3/4"			
25030-9				0.770"	14"	16"			

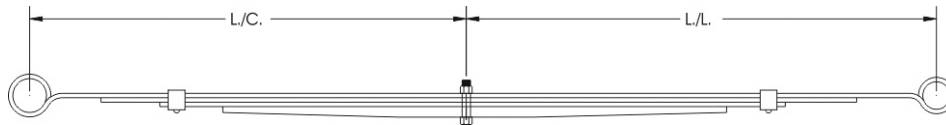

# SANDOVAL	# ORIGINAL	MODELO	ANCHO	ESPESOR	L./C.	L./L.	BRÍO	BUJE L./C.	BUJE L./L.
21026-C	15568339	Blazer Mod. 95 / Trasera	2 1/2"	0.262"	26"	28"	7 3/4"		
21026-C1				0.262"	26"	28"		RB-67	RB-159
21026-C2				0.262"	21 3/4"	23 1/4"			
21026-C2RD				0.262"	26"	28"			
21026-C3				0.262"	18 1/4"	19"			
21026-C4				0.625"	14 1/2"	15 1/2"			

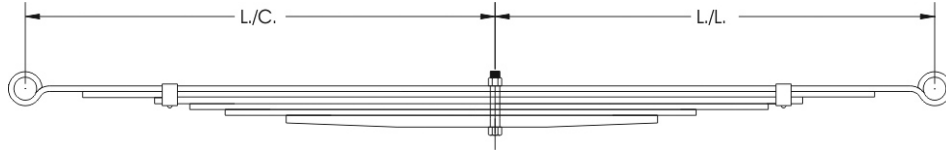

# SANDOVAL	# ORIGINAL	MODELO	ANCHO	ESPESOR	L./C.	L./L.	BRÍO	BUJE L./C.	BUJE L./L.
23127-SER	15568339	Blazer Rod. sencillo Silverado Mod. 99-01 / Trasera	2 1/2"	0.360"	27"	27"	4"		
23127-SER1				0.360"	27"	27"	4"	RB-117	RB-117
23127-SER2				0.360"	24 1/2"	24 1/2"	3 1/2"		
23127-SER2RD				0.360"	27"	25"	4"		
23127-SER3				0.360"	22 1/2"	22 1/2"	2 7/8"		

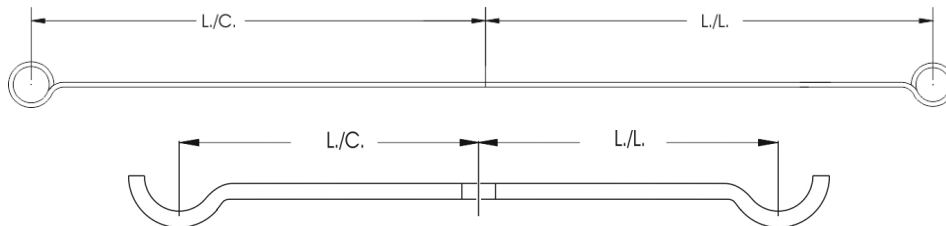

# SANDOVAL	# ORIGINAL	MODELO	ANCHO	ESPESOR	L./C.	L./L.	BRÍO	BUJE L./C.	BUJE L./L.
27032-CH	93423938	C3500 Doble Rodado Mod. 92-98 / Delantera	2 1/2"	0.447"	32"	32"	6 1/8"		
27032-CH1				0.447"	32"	32"		RB-117	RB-117
27032-CH2RD				0.447"	32"	32"			

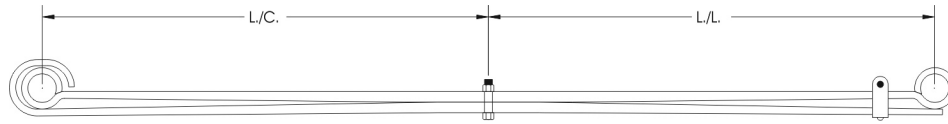

# SANDOVAL	# ORIGINAL	MODELO	ANCHO	ESPESOR	L./C.	L./L.	BRÍO	BUJE L./C	BUJE L./L
28828-CH	15638995	Camioneta HD-3500 Mod. 99-03 / Delantera	3"	0.662"	28 1/2"	28 1/2"	3 5/8" +		
28828-CH1				0.662"	28 1/2"	28 1/2"		RB-117 C/ CEJA	RB-117 C/ CEJA
28828-CH2				0.662"	28 1/2"	29 1/2"			
28828-CH2E				0.662"	28 1/2"	29 1/2"			
28828-CH3R				0.662"	29 1/2"	29 1/2"			

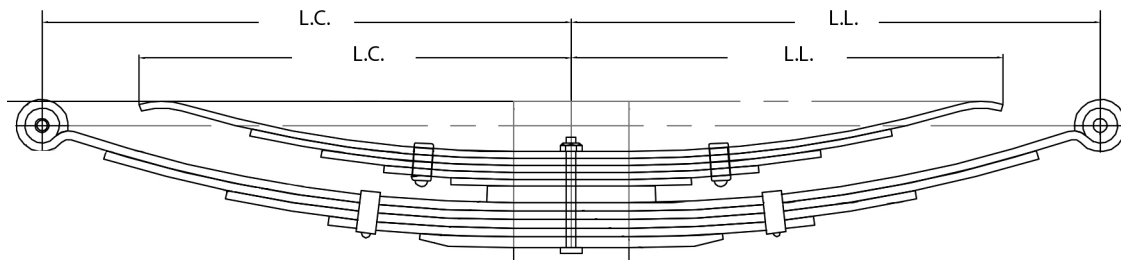

# SANDOVAL	# ORIGINAL	MODELO	ANCHO	ESPESOR	L./C.	L./L.	BRÍO	BUJE L./C	BUJE L./L
37028-CH	15636134	Camioneta HD-3500 Mod. 98-00 / Trasera	3"	0.447"	28"	28"	4"		
37028-CH1				0.447"	28"	28"		RB-218	RB-219
37028-CH2				0.447"	24 1/2"	24 1/2"			
37028-CH2R				0.447"	28"	25 1/2"			
37028-CH2RD				0.447"	28"	28"			
37028-CH3				0.447"	18"	18"			
37028-CH4				0.447"	12 5/8"	12 5/8"			
37028-CH5				0.558"	7 7/8"	7 7/8"			

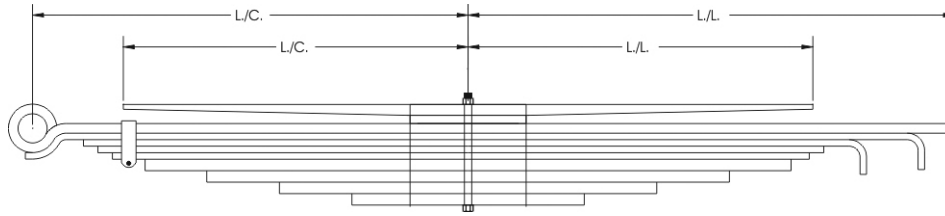

# SANDOVAL	# ORIGINAL	MODELO	ANCHO	ESPEJOR	L./C.	L./L.	BRÍO	BUJE L./C	BUJE L./L
39729-K	15641031	Camion Kodiak Diesel Mod. 95-99 / Trasera	3"	0.662"	29 13/16"	33 3/8"	5"		
39729-K1				0.662"	29 13/16"	33 3/8"		RB-191	
39729-K2				0.447"	29 13/16"	31 1/8"			
39729-K2M				0.662"	30"	31"			
39729-K3				0.447"	26 1/2"	27"			
39729-K4				0.447"	25 1/2"	24 1/2"			
39729-K5				0.447"	24 1/2"	23 1/2"			
39729-K6				0.788"	22 1/4"	23"			
39729-K7				0.788"	18"	18"			
39729-K8				0.788"	13"	13"			
39729-K9				0.788"	8"	8"			

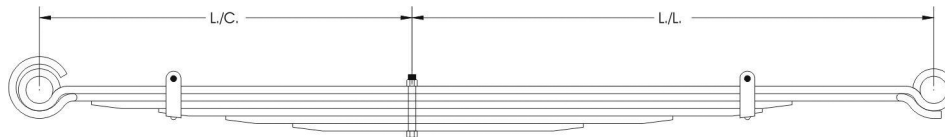

# SANDOVAL	# ORIGINAL	MODELO	ANCHO	ESPEJOR	L./C.	L./L.	BRÍO	BUJE L./C	BUJE L./L
42025-K	93427625	Kodiak 7000 lbs Mod. 97 / Delan-tera	4"	0.449"	25"	35"	6 1/2"		
42025-K1				0.449"	25"	35"		RB-190	RB-190
42025-K2				0.449"	25"	35"			
42025-K3				0.449"	21 1/2"	25 1/2"			
42025-K4				0.449"	17"	23 1/2"			
42025-K5				0.449"	12 1/2"	17 1/2"			
42025-K6				0.449"	8"	11 1/2"			

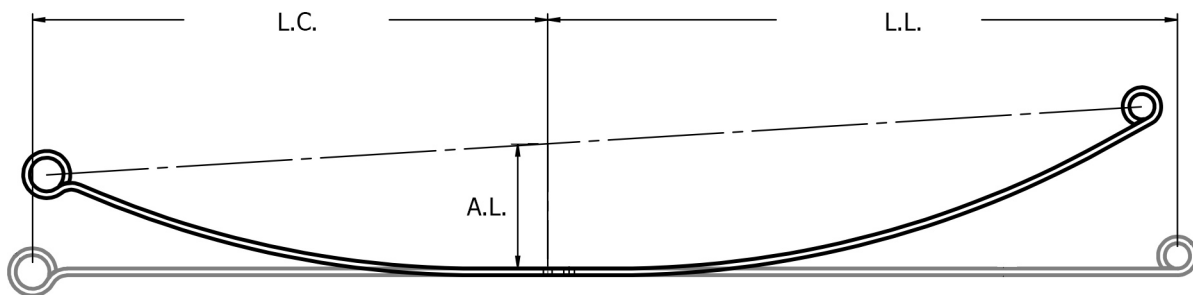

# SANDOVAL	# ORIGINAL	MODELO	ANCHO	ESPESOR	L./C.	L./L.	BRÍO	BUJE L./C	BUJE L./L
CH-0002-1	93427625	S-10 Mod. 2006	60 mm	8 mm	24 1/8"	29 1/2"	5.827"	40 mm	30 mm

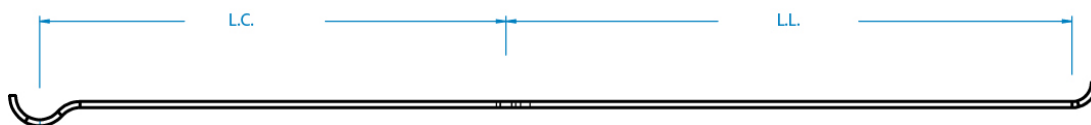

# SANDOVAL	# ORIGINAL	MODELO	ANCHO	ESPESOR	L./C.	L./L.	BRÍO	BUJE L./C	BUJE L./L
CH-0002-2RD	93427625	Refuerzo S-10 Mod. 2006	60 mm	8 mm	616 mm	748 mm	5.827"	N/A	N/A

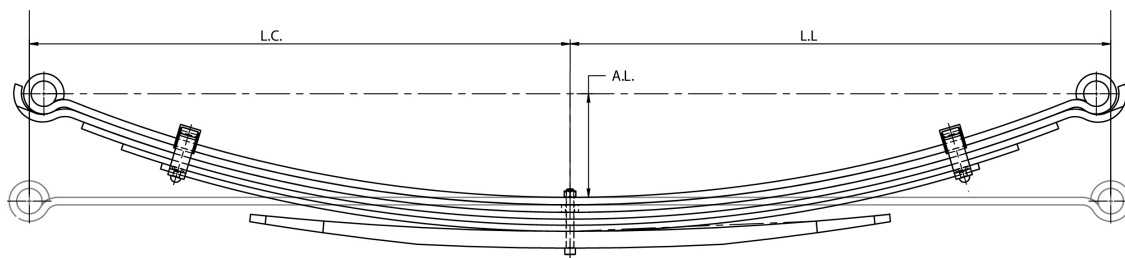

# SANDOVAL	# ORIGINAL	MODELO	ANCHO	ESPESOR	L./C.	L./L.	BRÍO	BUJE L./C	BUJE L./L
CH-0004	-	-	2 1/2"	0.447"	32"	32"	6 1/8"		
CH-0004-1			2 1/2"	0.447"	32"	32"		1 1/2"	1 1/2"
CH-0004-2			2 1/2"	0.447"	32"	32"			
CH-0004-3			2 1/2"	0.401"	29 1/2"	29 1/2"			
CH-0004-4			2 1/2"	0.360"	27"	27"			
CH-0004-5			2 1/2"	0.360"	24 1/2"	24 1/2"			
CH-0004-6			2 1/2"	0.999"	19"	19"			

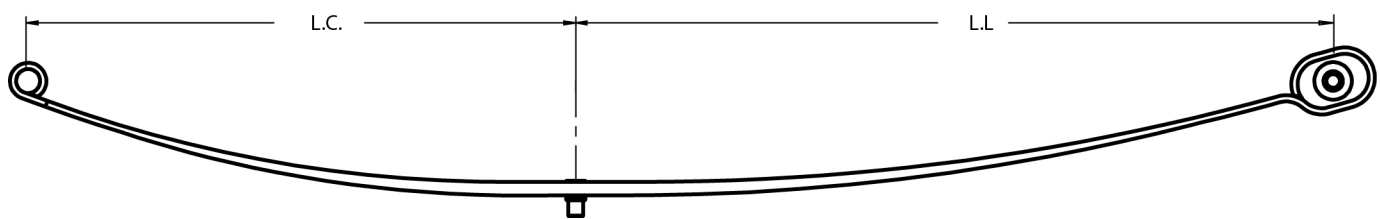

# SANDOVAL	# ORIGINAL	MODELO	ANCHO	ESPESOR	L./C.	L./L.	BRÍO	BUJE L./C	BUJE L./L
CR-0001	93427625	Town & Country 2004-2007	2.5"	0.558"	23 1/2"	32"	4 1/2"	RB-139	RB-139

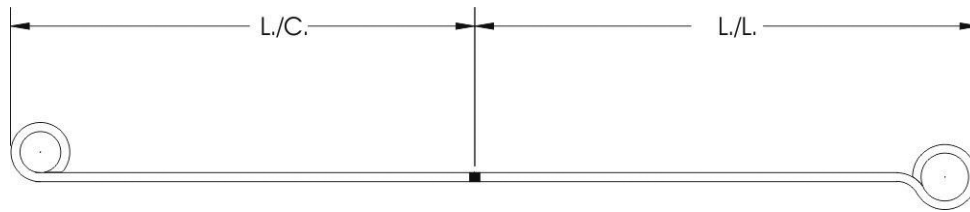

# SANDOVAL	# ORIGINAL	MODELO	ANCHO	ESPESOR	L./C.	L./L.	BRÍO	BUJE L./C	BUJE L./L
21124-E	-	Voyager Americana / Trasera	2 1/2"	0.262"	24 1/2"	27 1/2"	5"	Goma 6088	RB-67

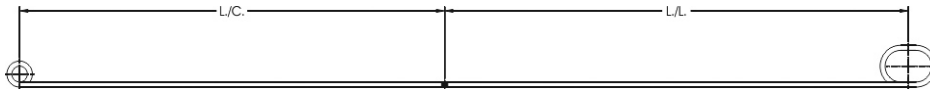

# SANDOVAL	# ORIGINAL	MODELO	ANCHO	ESPESOR	L./C.	L./L.	BRÍO	BUJE L./C	BUJE L./L
25027-DG1	-	Voyager Mod. 95-98 / Trasera	2 1/2"	0.323"	27 1/2"	30"	5 1/2"	Goma 6088	RB-139

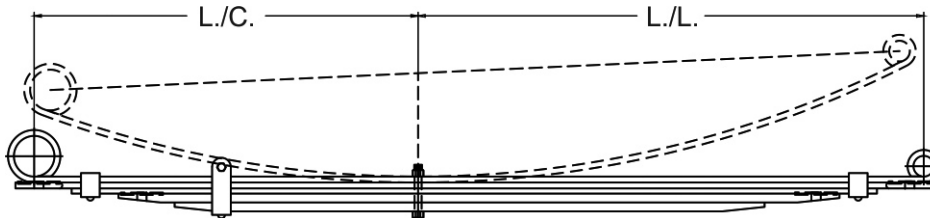

# SANDOVAL	# ORIGINAL	MODELO	ANCHO	ESPESOR	L./C.	L./L.	BRÍO	BUJE L./C	BUJE L./L
27920-DG	551004F700	H100 Pick Up Mod. 02-05 / Trasera	70 mm	8 mm	20 1/2"	27"	5 1/2"		
27920-DG1				8 mm	20 1/2"	27"		RB-67	RB-52
27920-DG2				8 mm	21 1/2"	27 1/2"			
27920-DG3				7 mm	18 1/2"	24 1/2"			
27920-DG4				12 mm	16"	22 1/2"			
27920-DG5				12 mm	13"	18 1/2"			

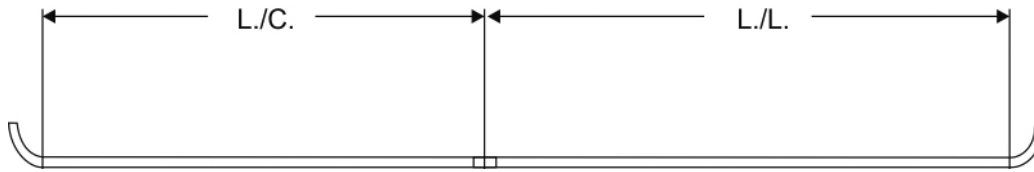

# SANDOVAL	# ORIGINAL	MODELO	ANCHO	ESPESOR	L./C.	L./L.	BRÍO	BUJE L./C	BUJE L./L
27927-DG2RD	-	Dodge H100 Pick Up Mod. 07-10 / Trasera	70 mm	8 mm	20 1/2"	27"	5 1/2"	N/A	N/A

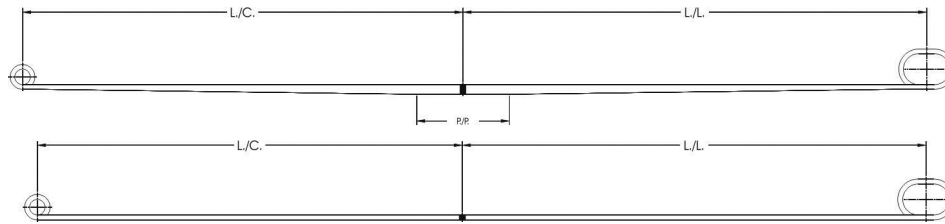

# SANDOVAL	# ORIGINAL	MODELO	ANCHO	ESPESOR	L./C.	L./L.	BRÍO	BUJE L./C	BUJE L./L
28828-DG1	-	Voyager Mod. 98 / Trasera	2 1/2"	0.625"	28 1/2"	30"	5 1/2"	Goma 6088	RB-139

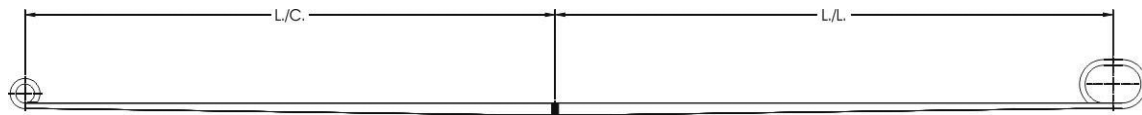

# SANDOVAL	# ORIGINAL	MODELO	ANCHO	ESPESOR	L./C.	L./L.	BRÍO	BUJE L./C	BUJE L./L
29624-V	4684604	Voyager Mod.2000 / Trasera	2 1/2"	0.558"	24 1/2"	30"	5 3/4"	Goma 6088	RB-139 (Ovalado)

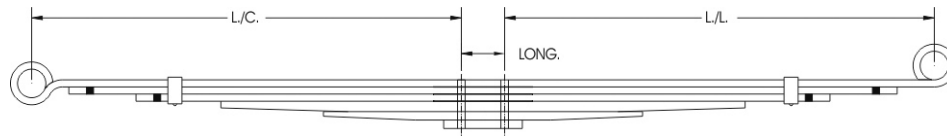

# SANDOVAL	# ORIGINAL	MODELO	ANCHO	ESPESOR	L./C.	Centro	L./L.	BRÍO	BUJE L./C	BUJE L./L
32030-DG	5271520AA	Dodge Ram 4000 Doble Rodado Mod 04-05 / Trasera	3"	0.499"	30 3/8"	3 1/16"	30 3/8"	4"		
32030-DG1				0.499"	30 3/8"	3 1/16"	30 3/8"		RB-273	RB-273
32030-DG2				0.499"	27 3/4"	3 1/16"	27 3/4"			
32030-DG2RD				0.499"	30 3/8"	3 1/16"	30 3/8"			
32030-DG3				0.499"	23"	3 1/16"	23"			
32030-DG4				0.788"	17"	3 1/16"	17"			
32030-DG5				0.558"	9 3/4"	3 1/16"	9 3/4"			
32030-DG6				0.558"	1 3/4"	3 1/16"	1 3/4"			

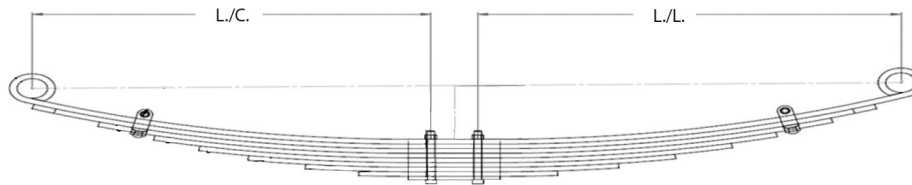

# SANDOVAL	# ORIGINAL	MODELO	ANCHO	ESPESOR	L./C.	Centro	L./L.	BRÍO	BUJE L./C	BUJE L./L
32029-DG	-	Dodge Ram 4000 Mod.2013 / Trasera	3"	0.499"	28 1/2"	3 1/16"	30 1/4"	5 1/2"		
32029-DG1				0.499"	28 1/2"	3 1/16"	30 1/4"	5 1/2"	RB-212	RB-212
32029-DG2				0.499"	28"	3 1/16"	28"	5 1/2"		
32029-DG2RD				0.499"	28 3/4"	3 1/16"	30 1/2"	6 1/8"		
32029-DG3				0.499"	23 1/2"	3 1/16"	25"	5 1/2"		
32029-DG4				0.499"	19 3/4"	3 1/16"	21 1/4"	5 1/2"		
32029-DG5				0.788"	16 3/4"	3 1/16"	18 1/4"	5 1/2"		
32029-DG6				0.558"	13 1/2"	3 1/16"	14 1/2"	5 1/2"		
32029-DG7				0.558"	9 3/4"	3 1/16"	10 3/4"	5 1/2"		
32029-DG8				0.558"	6 1/4"	3 1/16"	6 3/4"	5 1/2"		
PAD				0.558"	1 15/32"	3 1/16"	1 15/32"	5 1/2"		

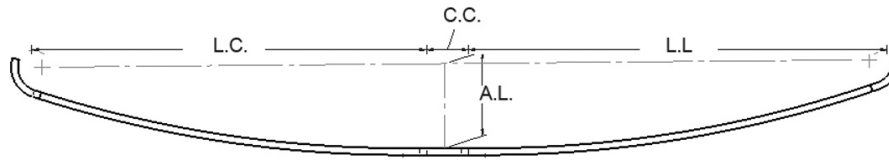

# SANDOVAL	# ORIGINAL	MODELO	ANCHO	ESPESOR	L./C.	C.C.	L./L.	BRÍO	BUJE L./C	BUJE L./L
32029-DG2RD	-	Dodge RAM 4000 Mod. 2013 / Trasera	3"	0.499"	28 3/4"	3 1/16"	30 1/2"	6 1/8"	N/A	N/A

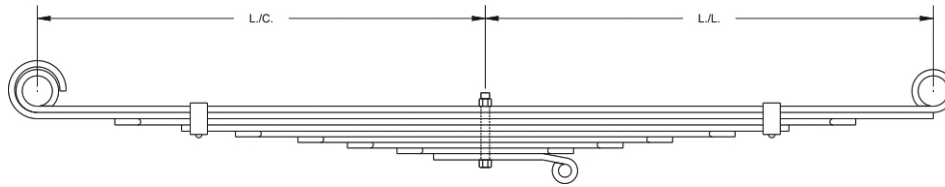

# SANDOVAL	# ORIGINAL	MODELO	ANCHO	ESPESOR	L./C.	L./L.	BRÍO	BUJE L./C	BUJE L./L
33026	3732825	D500, PD600 Mod. 77-83 / Delantera	3"	0.360"	26"	26"	5 1/16"		
33026-1				0.360"	26"	26"		RB-135	RB-135
33026-2				0.360"	26"	26"			
33026-3				0.360"	21 1/2"	21 1/2"			
33026-3R				0.360"	24"	24"			
33026-4				0.360"	17 5/8"	17 5/8"			
33026-5				0.323"	14 1/2"	14 1/2"			
33026-5R				0.360"	12 1/2"	12 1/2"			
33026-6				0.323"	10 7/8"	10 7/8"			
33026-7				0.323"	8"	8"			
33026-8				0.323"	5 1/8"	5 1/8"			
33026-9				0.360"	3"	4 5/8"			

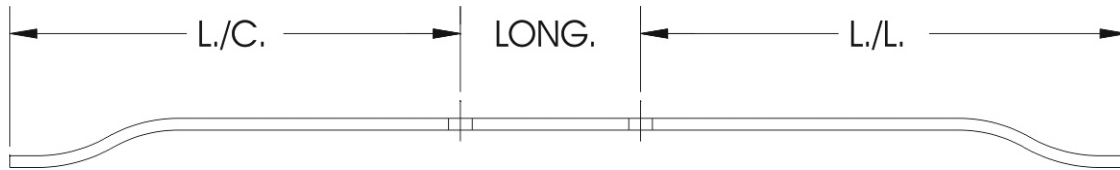

# SANDOVAL	# ORIGINAL	MODELO	ANCHO	ESPESOR	L./C.	L./L.	BRÍO	BUJE L./C	BUJE L./L
18131-CV	-	Caja de Velocidades Mod. 91-95 / Delantera	2"	0.323"	12 1/2"	13 1/2"	Especial	N/A	N/A

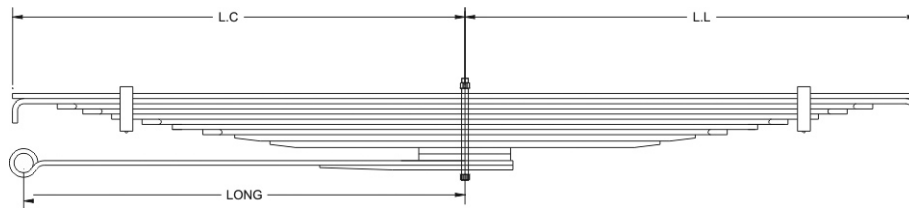

# SANDOVAL	# ORIGINAL	MODELO	ANCHO	ESPESOR	L./C.	L./L.	BRÍO	BUJE L./C	BUJE L./L
32030	471292C91	Famsa 551 Mod. 90-91 / Trasera	3"	0.499"	30 1/4"	30 1/4"	6 3/4"		
32030-1				0.499"	30 1/4"	30 1/4"			
32030-2				0.499"	27 1/2"	27 1/2"			
32030-3				0.499"	24"	24"			
32030-4				0.499"	21 1/4"	21 1/4"			
32030-5				0.499"	18 1/2"	18 1/2"			
32030-6				0.499"	15 5/8"	15 5/8"			
32030-7				0.447"	12 7/8"	12 7/8"			
32030-8				0.447"	10 5/8"	10 5/8"			
32030-9				0.447"	8 1/2"	8 1/2"			
32030-10				0.447"	6 1/4"	6 1/4"			
PAD				0.447"	3 3/4"	3 3/4"			
PAD				0.447"	3 3/4"	3 3/4"			
32030-13				0.447"	26 1/2"	3 3/4"		RNG	
32030-13R				0.447"	26 1/2"	3 3/4"			
32030-14				0.447"	11 1/4"	3 3/4"			

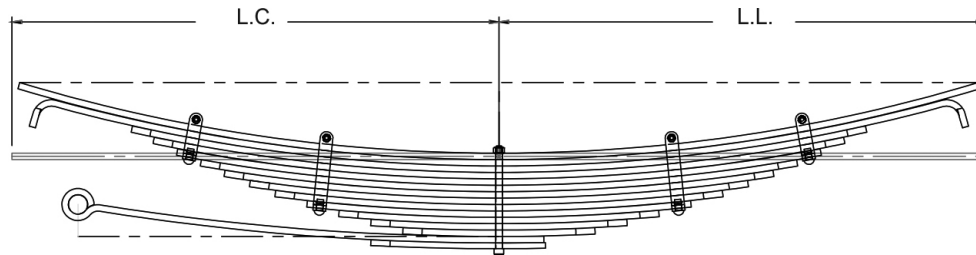

# SANDOVAL	# ORIGINAL	MODELO	ANCHO	ESPESOR	L./C.	L./L.	BRÍO	BUJE L./C	BUJE L./L
32038	A1453219	D500 Mod. 65-85 / Trasera	3"	0.499"	38"	38"	5 1/2"		
32038-1				0.499"	38"	38"			
32038-2				0.499"	36"	36"			
32038-3				0.499"	28 7/8"	28 7/8"			
32038-4				0.499"	27 1/8"	27 1/8"			
32038-5				0.499"	25 1/4"	25 1/4"			
32038-6				0.447"	23 3/8"	23 3/8"			
32038-7				0.447"	21 1/2"	21 1/2"			
32038-8				0.447"	19 1/2"	19 1/2"			
32038-9				0.447"	17 1/2"	17 1/2"			
32038-10				0.447"	15"	15"			
32038-11				0.447"	12 1/2"	12 1/2"			
32038-12				0.447"	10"	10"			
32038-13				0.447"	7 1/2"	7 1/2"			
32038-14				0.499"	33"	3 1/2"		RNG	
32038-15				0.447"	10"	3 5/8"			
32038-15R				0.499"	33"	3 1/2"			

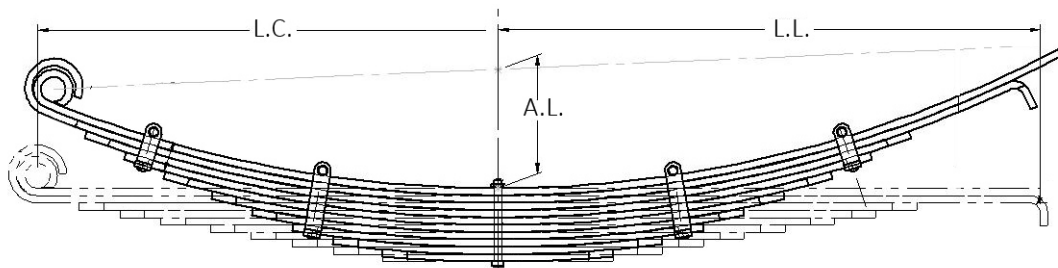

# SANDOVAL	# ORIGINAL	MODELO	ANCHO	ESPESOR	L./C.	L./L.	BRÍO	BUJE L./C	BUJE L./L
37036	-	D-60 / Delantera	3"	0.447"	28"	36"	6"		
37036-1				0.447"	28"	38"		RNG	
37036-2				0.447"	28"	33"			
37036-3				0.447"	25 1/2"	25 1/2"			
37036-4				0.447"	23"	23"			
37036-5				0.447"	20 1/2"	20 1/2"			
37036-6				0.447"	17 1/2"	17 1/2"			
37036-7				0.447"	15"	15"			
37036-8				0.447"	12 1/2"	12 1/2"			
37036-9				0.401"	10"	10"			
37036-10				0.401"	7"	7"			

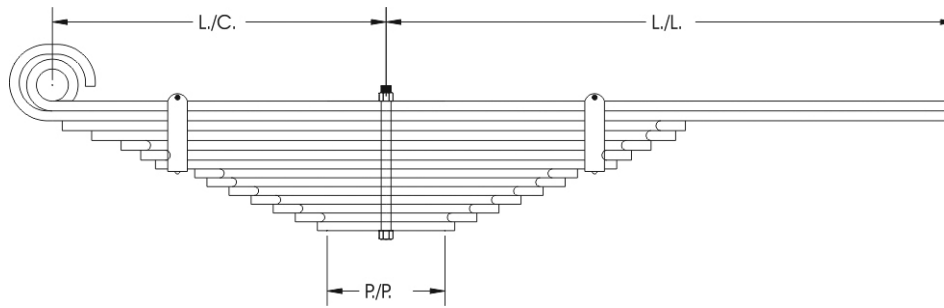

# SANDOVAL	# ORIGINAL	MODELO	ANCHO	ESPESOR	L./C.	L./L.	BRÍO	BUJE L./C	BUJE L./L
42028	A24532-19	Susp. Hend. Dina 800,861 Mod. 67- 87 / Trasera	4"	0.499"	17"	29"	2"		
42028-1				0.499"	17"	29"		TPK	
42028-2				0.499"	17"	29"			
42028-3				0.499"	16 1/2"	15 1/4"			
42028-3R				0.499"	17"	29"			
42028-4				0.499"	15"	14 3/4"			
42028-5				0.499"	13 1/2"	13 1/2"			
42028-6				0.499"	12 1/2"	12 1/2"			
42028-7				0.447"	11 3/4"	11 3/4"			
42028-8				0.447"	9 3/4"	9 3/4"			
42028-9				0.447"	9 1/8"	9 1/8"			
42028-10				0.447"	8"	8"			
42028-11				0.447"	6 7/8"	6 7/8"			
42028-12				0.447"	5 3/4"	5 3/4"			
42028-13				0.447"	4 5/8"	4 5/8"			
42028-14				0.401"	3 1/2"	3 1/2"			

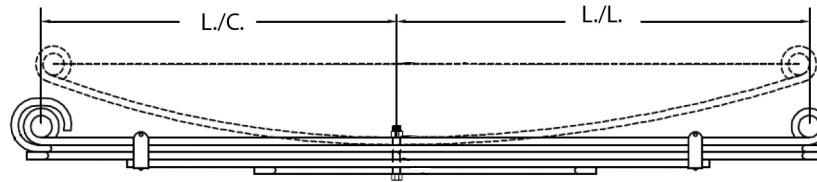

# SANDOVAL	# ORIGINAL	MODELO	ANCHO	ESPESOR	L./C.	L./L.	BRÍO	BUJE L./C.	BUJE L./L.
42029-D	640C030080	S-500 Mod. 92-94 / Delantera	4"	0.499	25"	29"	5"		
42029-D1				0.499	25"	29"		RNK	RNK
42029-D2				0.499	25"	30"			
42029-D3				0.499	26"	30"			
42029-D4				0.499	19"	22"			
42029-D5				0.499	10"	14"			

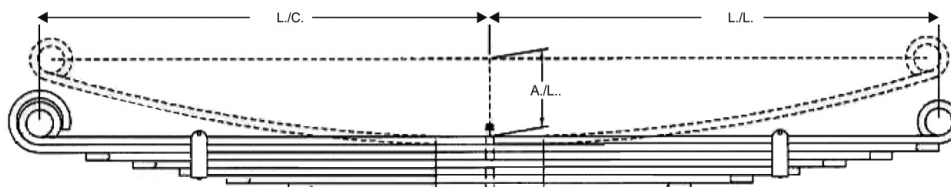

# SANDOVAL	# ORIGINAL	MODELO	ANCHO	ESPESOR	L./C.	L./L.	BRÍO	BUJE L./C.	BUJE L./L.
42029-V	1653685C91	S9400 Mod. 91-98 / Delantera	4"	0.499	29"	29"	3 15/16"		
42029-V1				0.499	29"	29"		1 3/4"	1 3/4"
42029-V2				0.499	29"	29"			
42029-V3				0.499	26"	26"			
42029-V4				0.499	23"	23"			
42029-V5				0.499	20"	20"			
42029-V6				0.499	17"	17"			
42029-V7				0.499	13"	13"			

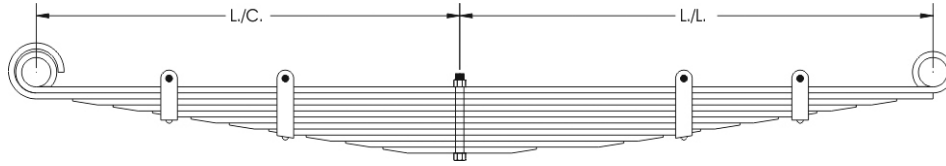

# SANDOVAL	# ORIGINAL	MODELO	ANCHO	ESPEJOR	L./C.	L./L.	BRÍO	BUJE L./C	BUJE L./L
43028	A1753018	Dina 800-,861 Mod. 85-86 / Delantera	4"	0.360"	25 1/2"	28 1/2"	6 1/8"		
43028-1				0.360"	25 1/2"	28 1/2"		TB-26 174026	TB-26 174026
43028-2				0.360"	25 1/2"	28 1/2"			
43028-3				0.360"	23 5/16"	26 1/16"			
43028-4				0.360"	20 7/8"	23 1/4"			
43028-5				0.360"	18 1/2"	20 3/8"			
43028-6				0.360"	16 3/16"	18"			
43028-7				0.360"	13 7/8"	15 3/16"			
43028-8				0.360"	11 1/2"	12 3/4"			
43028-9				0.360"	9 1/4"	10"			
43028-10				0.360"	6 3/8"	7 3/8"			
43028-11				0.360"	4 5/8"	4 5/8"			

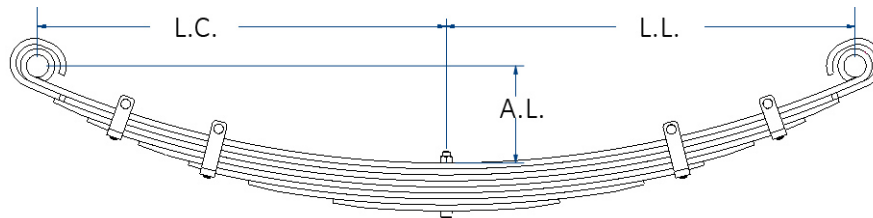

# SANDOVAL	# ORIGINAL	MODELO	ANCHO	ESPEJOR	L./C.	L./L.	BRÍO	BUJE L./C	BUJE L./L
44028	-	Trasera	4"	0.041"	28 9/16"	28 9/16"	6 1/2"		
44028-1				0.360"	28 9/16"	28 9/16"		RNK	RNK
44028-2				0.360"	28 9/16"	28 9/16"			
44028-3				0.360"	27 1/16"	27 1/16"			
44028-4				0.360"	24 5/8"	24 5/8"			
44028-5				0.360"	21"	21"			
44028-6				0.360"	17 1/2"	17 1/2"			
44028-7				0.360"	13 3/8"	13 3/8"			
44028-8				0.360"	7 5/8"	7 5/8"			

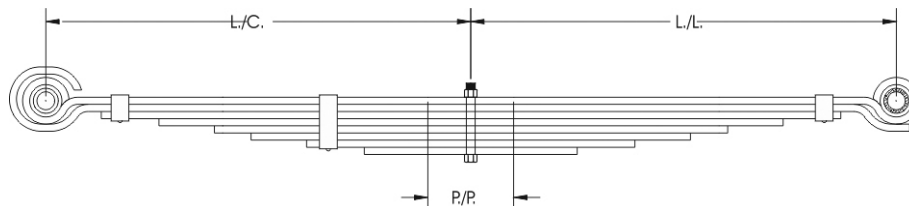

# SANDOVAL	# ORIGINAL	MODELO	ANCHO	ESPESOR	L./C.	L./L.	BRÍO	BUJE L./C	BUJE L./L
47025-GR	8234M891	S600 Mod. 94-98 / Delantera	4"	0.447"	25"	29"	4 1/2"		
47025-GR1				0.447"	25"	29"		RNK	RNK
47025-GR2				0.447"	25"	29 1/2"			
47025-GR3				0.447"	22 1/4"	25 3/4"			
47025-GR4				0.447"	19 1/2"	22 1/2"			
47025-GR5				0.447"	16 3/4"	19 1/4"			
47025-GR6				0.447"	14"	16"			
47025-GR7				0.447"	11 1/4"	12 3/4"			
47025-GR8				0.447"	8 1/2"	9 1/2"			

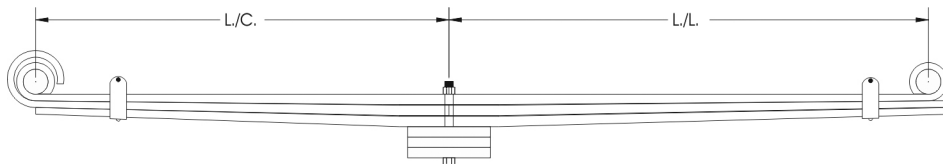

# SANDOVAL	# ORIGINAL	MODELO	ANCHO	ESPESOR	L./C.	L./L.	BRÍO	BUJE L./C	BUJE L./L
48029	2996707C92	Camión S-500 10800 lbs Mod. 92-98 / Delantera	4"	0.662"	25"	29"	5 7/8"		
48029-1				0.662"	25"	29"		BM-RNK	BM-RNK
48029-2				0.662"	25"	30 1/2"			
48029-3				0.662"	26"	30 1/2"			
PAD				0.662"	2 1/2"	2 1/2"			
PAD				0.662"	2 1/2"	2 1/2"			
PAD				0.662"	2 1/2"	2 1/2"			

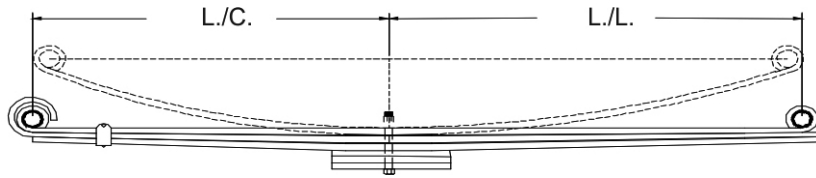

# SANDOVAL	# ORIGINAL	MODELO	ANCHO	ESPESOR	L./C.	L./L.	BRÍO	BUJE L./C	BUJE L./L
48029-RM	1654700C91	S-500, Mod. 78-88 / Delantera	4"	0.662"	25"	29"	5 7/8"		
48029-RM1				0.662"	25"	29"		TB-26	TB-26
48029-RM2				0.662"	25"	30 1/2"			
48029-RM3				0.662"	26"	30 1/2"			

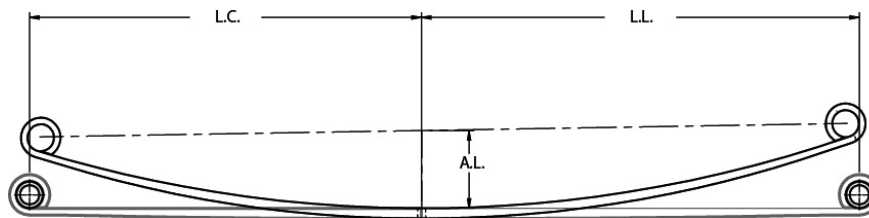

# SANDOVAL	# ORIGINAL	MODELO	ANCHO	ESPESOR	L./C.	L./L.	BRÍO	BUJE L./C	BUJE L./L
48125-FE	477649C91	Americana / Delantera	4"	0.662"	25 1/2"	28 1/2"	5"	TB-26	TB-26

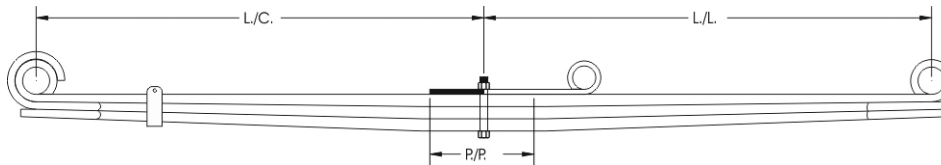

# SANDOVAL	# ORIGINAL	MODELO	ANCHO	ESPESOR	L./C.	L./L.	BRÍO	BUJE L./C	BUJE L./L
49029-S	1653685C91	Tractocamion S-9400 14000 lbs. Mod. 93 / Delantera	4"	0.788"	29"	29"	5"		
49029-S1				0.788"	29"	29"		TB-26 C/caja	TB-26 C/caja
49029-S2				0.788"	29"	30"			
49029-S3				0.788"	30"	30"			
49029-S4				0.323"	3 1/2"	6 1/2"			

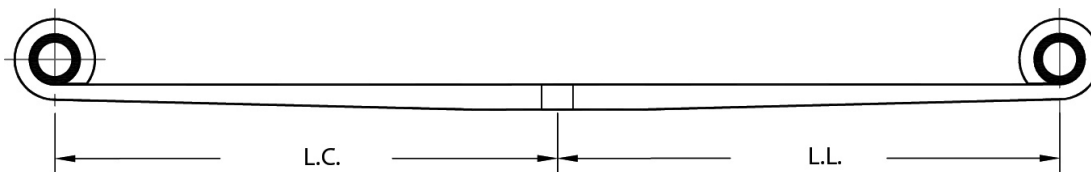

# SANDOVAL	# ORIGINAL	MODELO	ANCHO	ESPESOR	L./C.	L./L.	BRÍO	BUJE L./C	BUJE L./L
49129-AQ	2994929C91	Tractocamion 7400 Mod. 97-98 / Delantera	4"	0.788"	29"	29"	5"	Buje de bronce RNK	Buje de bronce RNK

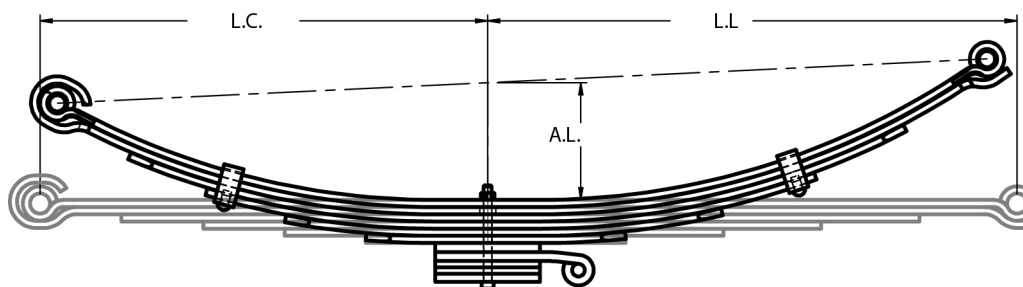

# SANDOVAL	# ORIGINAL	MODELO	ANCHO	ESPESOR	L./C.	L./L.	BRÍO	BUJE L./C	BUJE L./L
DI-0001	-	Camión Runner Delantera	4"	0.447"	710 mm	840 mm	185 mm	BM-NJK	BM-NJK
DI-0001-1			4"	0.447"	710mm	840 mm			
DI-0001-2			4"	0.447"	710 mm	840 mm			
DI-0001-3			4"	0.447"	581 mm	685 mm			
DI-0001-4			4"	0.447"	451 mm	529 mm			
DI-0001-5			4"	0.447"	322 mm	374 mm			
DI-0001-6			4"	0.447"	193 mm	219 mm			
PAD			4"	0.558"	83 mm	83 mm			
BRACKET			4"	0.558"	83 mm	144 mm			
PAD			4"	0.401"	83 mm	83 mm			
PAD			4"	0.401"	83 mm	83 mm			
PAD			4"	0.499"	83 mm	83 mm			

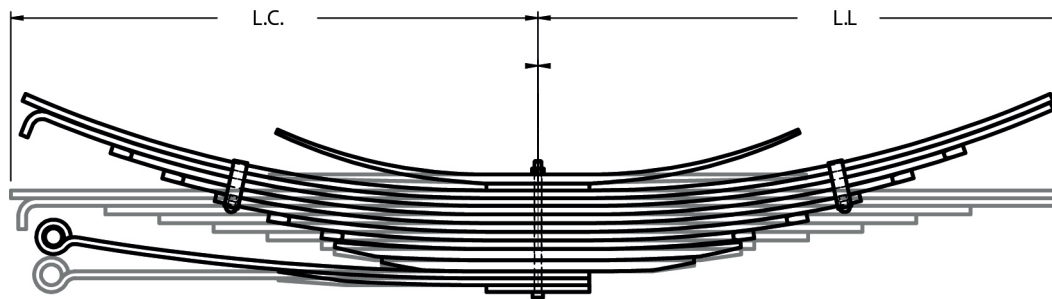

# SANDOVAL	# ORIGINAL	MODELO	ANCHO	ESPESOR	L./C.	L./L.	BRÍO	BUJE L./C	BUJE L./L
DI-0002	-	Runner 10 y Linner Trasera	3"	0.447"	710 mm	840 mm	82.6mm		
DI-0002-01			3"	0.662"	496mm	496mm	82.6 mm		
PAD			3"	0.499"	95 mm	95 mm			
DI-0002-1			3"	0.558"	975 mm	975 mm			
DI-0002-2			3"	0.558"	961 mm	961 mm			
DI-0002-3			3"	0.625"	800 mm	800 mm			
DI-0002-4			3"	0.625"	700 mm	700 mm			
DI-0002-5			3"	0.625"	600 mm	600 mm			
DI-0002-6			3"	0.625"	500 mm	500 mm			
DI-0002-7			3"	0.625"	400 mm	400 mm			
DI-0002-8			3"	0.812"	376 mm	376 mm			
DI-0002-9			3"	0.812"	289 mm	289 mm			
DI-0002-10			3"	0.499"	95 mm	95 mm		BM-RNG	
DI-0002-11			3"	0.499"	95 mm	95 mm			
PAD			3"	0.499"	95 mm	95 mm			

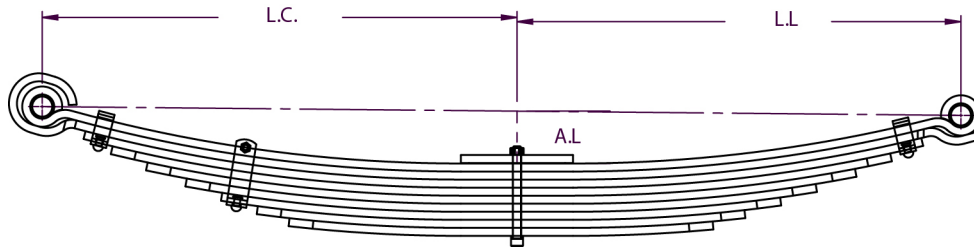

# SANDOVAL	# ORIGINAL	MODELO	ANCHO	ESPESOR	L./C.	L./L.	BRÍO	BUJE L./C	BUJE L./L
DI-0003	-	Runner 10 y Linner Trasera	3"	0.499"	30"	28"	3 1/2"		
PAD			3"	0.499"	3 1/2"	3 1/2"			
DI-0003-1			3"	0.499"	30"	28"		BM-RNG	BM-RNG
DI-0003-2			3"	0.499"	30"	28"			
DI-0003-3			3"	0.499"	27 1/4"	25 1/2"			
DI-0003-4			3"	0.499"	25 1/2"	23 1/2"			
DI-0003-5			3"	0.499"	23 1/4"	21 1/4"			
DI-0003-6			3"	0.499"	30 3/4"	18 3/4"			
DI-0003-7			3"	0.499"	18 1/2"	16 1/2"			
DI-0003-8			3"	0.499"	16 1/4"	14 1/4"			
DI-0003-9			3"	0.499"	14 1/4"	12 1/4"			

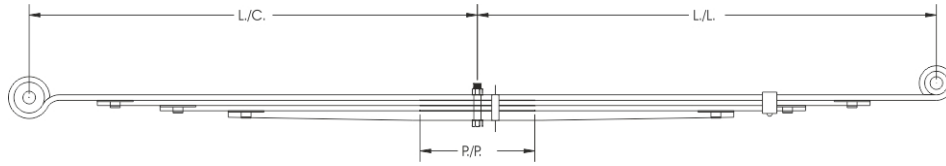

# SANDOVAL	# ORIGINAL	MODELO	ANCHO	ESPESOR	L./C.	L./L.	BRÍO	BUJE L./C	BUJE L./C
23032-DG	-	DOGE RAM TRAS PICK UP 2002-2005	2 1/2"	0.360"	31 1/4"	32"	6 3/4"		
23032-DG1			2 1/2"	0.360"	31 1/4"	32"		RB-272CR	RB-271CR
23032-DG2			2 1/2"	0.360"	26 1/2"	27 3/8"			
23032-DG2RD			2 1/2"	0.360"	31 1/4"	32"			
23032-DG3			2 1/2"	0.360"	22 1/8"	22 7/8"			
23032-DG4			2 1/2"	0.702"	17 3/8"	17 7/8"			

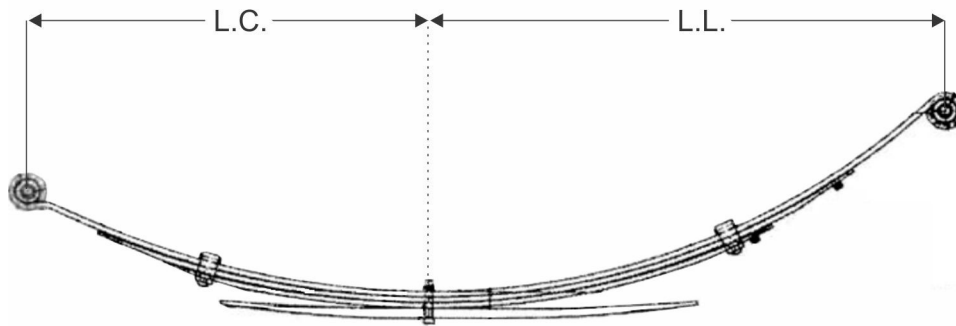

# SANDOVAL	# ORIGINAL	MODELO	ANCHO	ESPESOR	L./C.	L./L.	BRÍO	BUJE L./C	BUJE L./L
34-1431-1	MFG 52106744AD	TRUCK	2 1/2"	0.323"	24"	32"	L.C. 5 1/4" L.L. 10.87"	RB-257CR	RB-257CR
34-1431-2R		REFUERZO	2 1/2"	0.323"	21"	29"	L.C. 4.47" L.L. 9.64"		

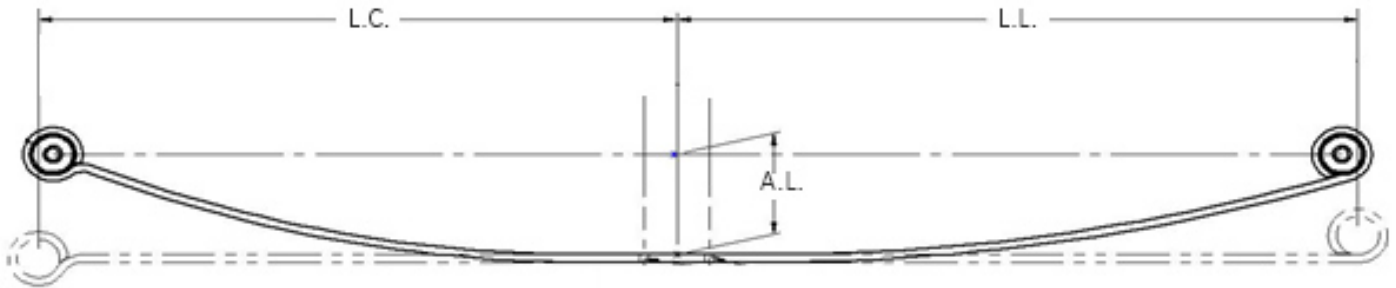

# SANDOVAL	# ORIGINAL	MODELO	ANCHO	ESPEJOR	L./C.	L./L.	BRÍO	BUJE L./C	BUJE L./L
34-1453-1	52113513AD	-	3"	0.401"	30"	32"	5 1/4"	RB-273CR	RB-273CR

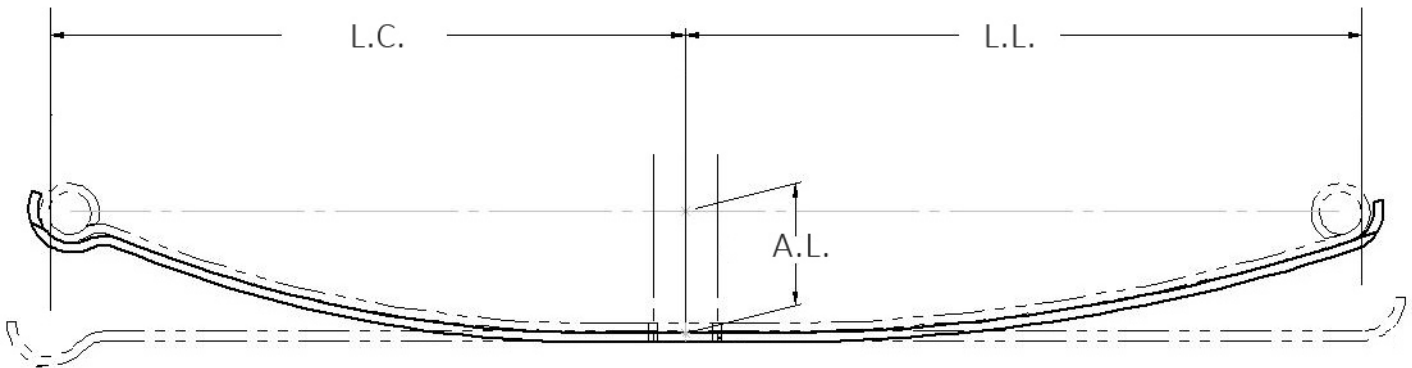

# SANDOVAL	# ORIGINAL	MODELO	ANCHO	ESPEJOR	L./C.	L./L.	BRÍO	BUJE L./C	BUJE L./L
34-1453-2RD	52113513AD	-	3"	0.401"	30 1/4"	32 1/4"	5 3/4"	N/A	N/A

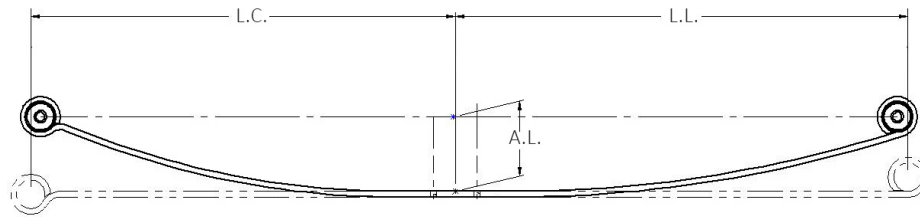

# SANDOVAL	# ORIGINAL	MODELO	ANCHO	ESPESOR	L./C.	L./L.	BRÍO	BUJE L./C	BUJE L./L
34-1459-1	52113319AD	-	3"	0.447"	30"	32"	5 1/4"	RB-273	RB-273

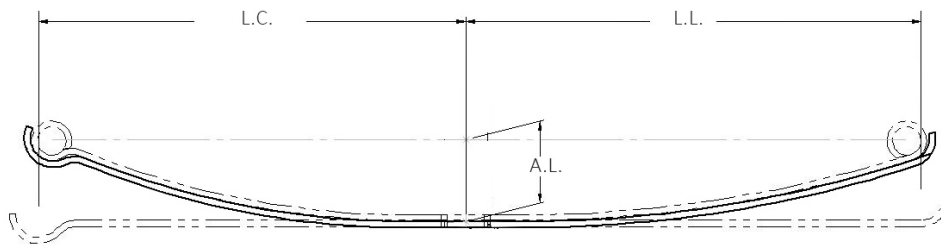

# SANDOVAL	# ORIGINAL	MODELO	ANCHO	ESPESOR	L./C.	L./L.	BRÍO	BUJE L./C	BUJE L./L
34-1459-2RD	52113319AD	-	3"	0.447"	30 1/4"	32 1/4"	5 13/16"	N/A	N/A

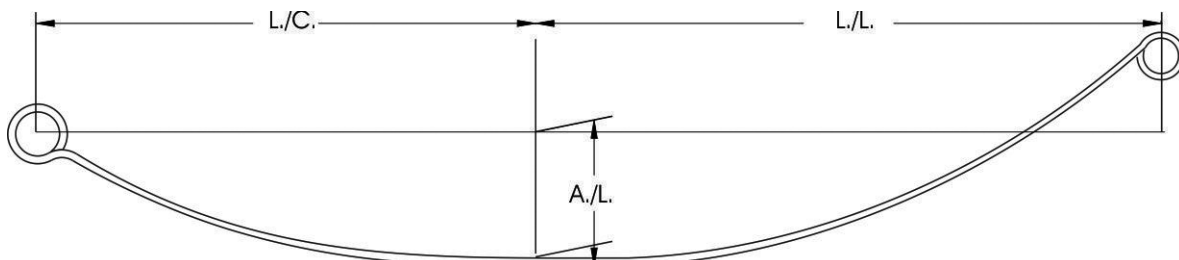

# SANDOVAL	# ORIGINAL	MODELO	ANCHO	ESPESOR	L./C.	L./L.	BRÍO	BUJE L./C	BUJE L./L
DG-0001	-	Dodge Dakota Mod.2011 / Trasera	2 1/2"	0.307"	24"	31"	7 1/4"	RB-67	RB-117

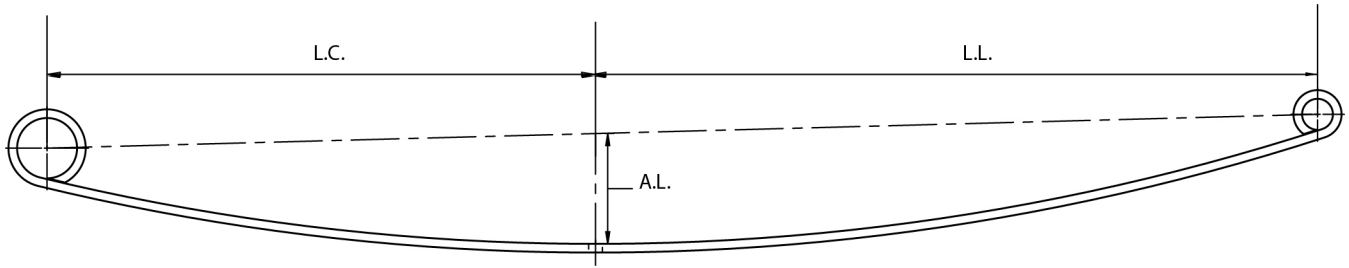

# SANDOVAL	# ORIGINAL	MODELO	ANCHO	ESPEJOR	L./C.	L./L.	BRÍO	BUJE L./C	BUJE L./L
DG-0002-1	-	H-100 Diesel	70	8	520	685	4"	2 3/16"	1 1/8"

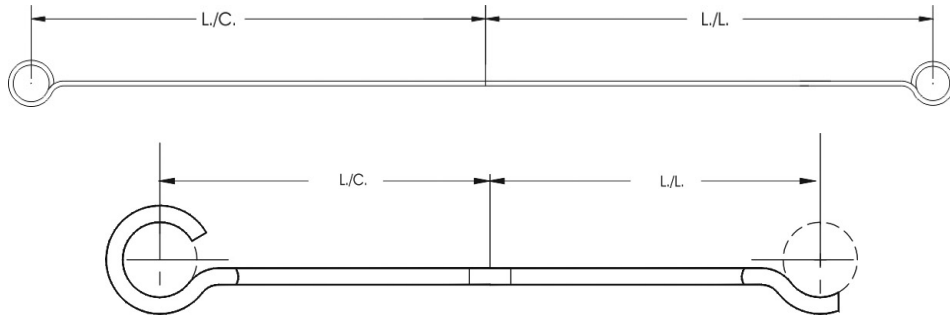

# SANDOVAL	# ORIGINAL	MODELO	ANCHO	ESPESOR	L./C.	L./L.	BRÍO	BUJE L./C.	BUJE L./L.
34125-B	572351C91	Boxer 1114-52 Mod. 90-92 / Delantera	3"	0.401"	25"	25"	4"	RB-75	RB-75
34225-B			3"	0.401"	25"	25"	4"	N/A	N/A

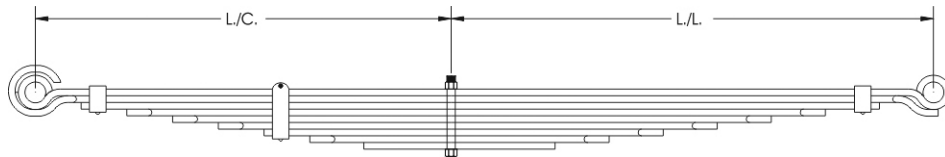

# SANDOVAL	# ORIGINAL	MODELO	ANCHO	ESPESOR	L./C.	L./L.	BRÍO	BUJE L./C.	BUJE L./L.
44029	471263C91	Tractocamion S-2500 Mod. 79- 92 / Delantera	4"	0.401"	25"	29"	5 5/8"		
44029-1				0.401"	25"	29"		NJK	NJK
44029-2				0.401"	25"	29"			
44029-3				0.401"	22 1/4"	25 3/4"			
44029-3R				0.401"	23"	27"			
44029-4				0.401"	19 1/2"	22 1/2"			
44029-5				0.401"	16 3/4"	19 1/4"			
44029-6				0.401"	14"	16"			
44029-7				0.401"	11 1/4"	12 3/4"			
44029-8				0.401"	8 1/2"	9 1/2"			
44029-9				0.401"	5 1/4"	6 1/4"			

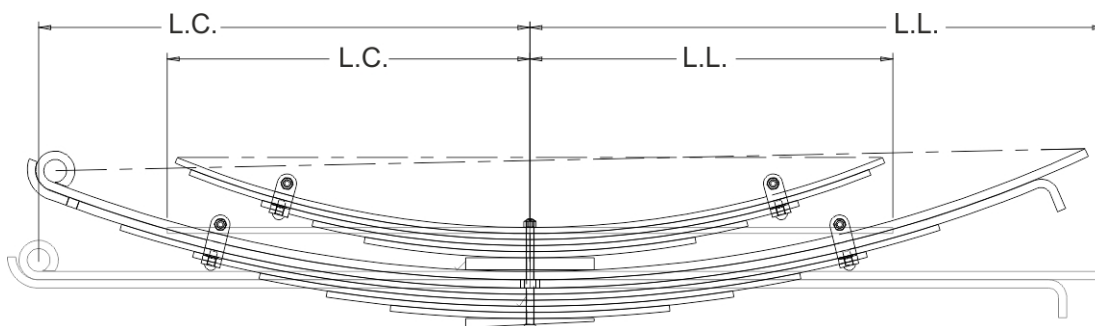

# SANDOVAL	# ORIGINAL	MODELO	ANCHO	ESPESOR	L./C.	L./L.	BRÍO	BUJE L./C	BUJE L./L
24726-CG	-	Changan Trasera	70 mm	11 mm	650	760	3.63"	N/A	N/A
24726-CG1			70 mm	11 mm	650	760		30	
24726-CG2			70 mm	11 mm	650	710			
24726-CG3			70 mm	8 mm	550	550			
24726-CG4			70 mm	8 mm	450	450			
24726-CG5			70 mm	8 mm	360	360			
24726-CG6			70 mm	8 mm	270	270			
24726-CG7			70 mm	8 mm	185	185			
CUÑA			70 mm	12 mm	85	85			
24726-CG01			70 mm	8 mm	480	480			
24726-CG02			70 mm	8 mm	460	460			
24726-CG03			70 mm	8 mm	360	360			
24726-CG04			70 mm	8 mm	290	290			
24726-CG05			70 mm	8 mm	220	220			
PAD			70 mm	16 mm	85	85			

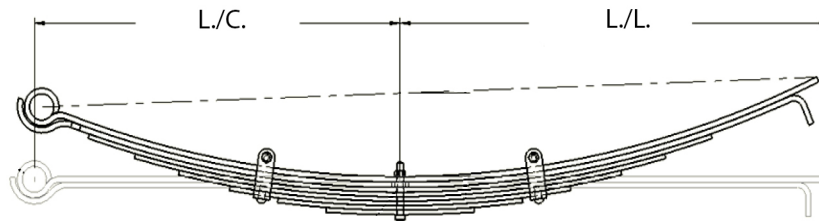

# SANDOVAL	# ORIGINAL	MODELO	ANCHO	ESPESOR	L./C.	L./L.	BRÍO	BUJE L./C	BUJE L./L
27922-CG	-	Changan Delantera	70 mm	8 mm	570	670	4.72"	N/A	N/A
27922-CG1			70 mm	8 mm	570	670		38	
27922-CG2			70 mm	8 mm	570	640			
27922-CG3			70 mm	7 mm	490	490			
27922-CG4			70 mm	7 mm	415	415			
27922-CG5			70 mm	7 mm	345	345			
27922-CG6			70 mm	6 mm	265	265			
27922-CG7			70 mm	6 mm	190	190			
27922-CG8			70 mm	6 mm	115	115			

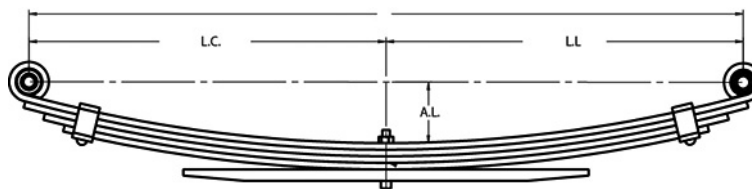

# SANDOVAL	# ORIGINAL	MODELO	ANCHO	ESPESOR	L./C.	L./L.	BRÍO	BUJE L./C	BUJE L./L
CG-0001	SC1025DF4	Changan	2.250"	0.323"	18"	18"	3"	-	-
CG-0001-1			2.250"	0.323"	18"	18"		RB-21	RB-70
CG-0001-1			2.250"	0.323"	18"	18"			
CG-0001-1			2.250"	0.323"	17"	17"			
CG-0001-1			2.250"	0.323"	16"	16"			
CG-0001-1			2.250"	0.558"	10"	10"			

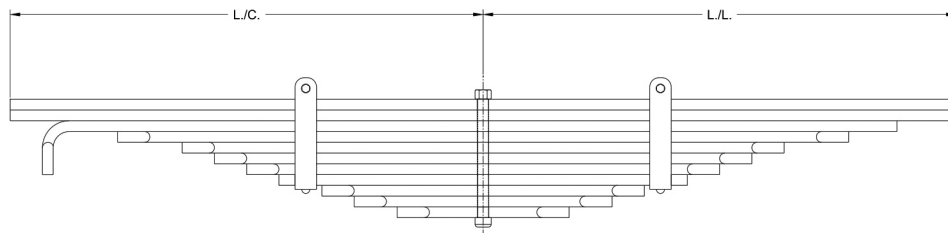

# SANDOVAL	# ORIGINAL	MODELO	ANCHO	ESPESOR	L./C.	L./L.	BRÍO	BUJE L./C	BUJE L./L
32022-H	-	Tandem Mod.66-94 / Trasera	3"	0.499"	22"	22"	4"	N/A	N/A
32022-H1				0.499"	22"	22"			
32022-H2				0.499"	22"	22"			
32022-H3				0.499"	20"	20"			
32022-H4				0.499"	17"	17"			
32022-H5				0.499"	14"	14"			
32022-H6				0.499"	12 1/2"	12 1/2"			
32022-H7				0.499"	11"	11"			
32022-H8				0.499"	9 1/2"	9 1/2"			
32022-H9				0.499"	7 1/2"	7 1/2"			
32022-H10				0.499"	6"	6"			
32022-H11				0.499"	4"	4"			

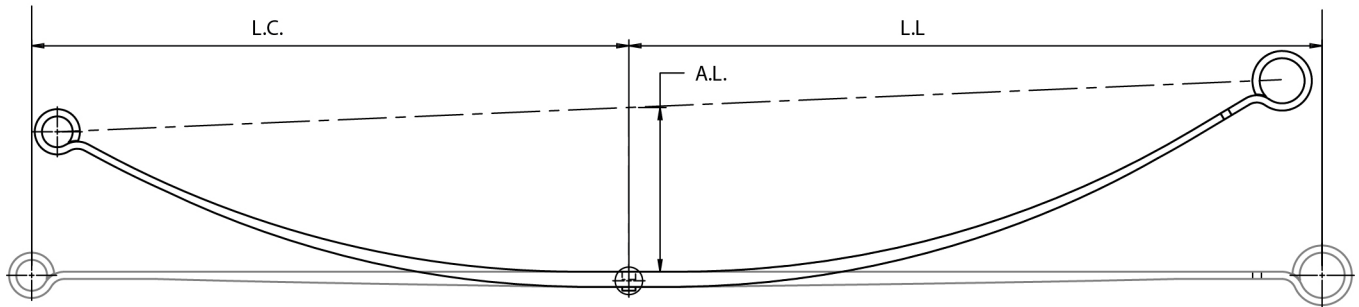

# SANDOVAL	# ORIGINAL	MODELO	ANCHO	ESPESOR	L./C.	L./L.	BRÍO	BUJE L./C	BUJE L./L
FI-0001-1	-	Fiat Strada Adventure	70mm	16 mm	632	733	6 7/8"	1 9/32"	1 7/8"

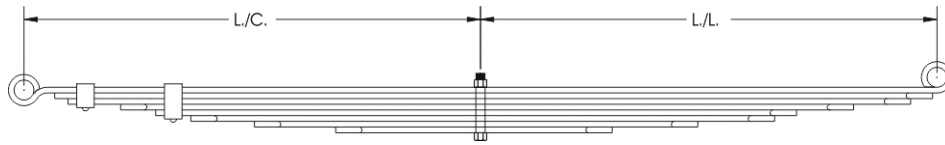

# SANDOVAL	# ORIGINAL	MODELO	ANCHO	ESPESOR	L./C.	L./L.	BRÍO	BUJE L./C	BUJE L./L
20026	C5TA5560DA	F350 Rodada Doble Mod. 67-76 / Trasera	4"	0.323"	26"	26"	7 1/4"		
20026-1				0.323"	26"	26"	7 1/4"	RB-101	RB-101
20026-2				0.323"	24 1/4"	25 1/4"	7 1/4"		
20026-2RD				0.323"	26"	26"	7 1/4"		
20026-3				0.323"	23 1/4"	23 1/4"	7 1/4"		
20026-4				0.323"	21 1/4"	21 1/4"	7 1/4"		
20026-5				0.323"	19 1/4"	19 1/4"	7 1/4"		
20026-6				0.401"	17"	17"	3/8"		
20026-7				0.401"	14"	14"	3/8"		
20026-8				0.401"	11"	11"	3/8"		
20026-9				0.401"	8"	8"	3/8"		
20026-10				0.401"	5"	5"	3/8"		

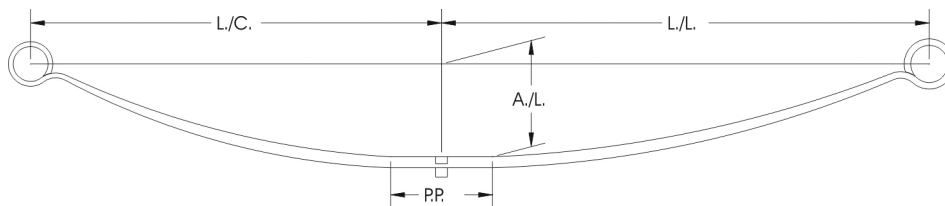

# SANDOVAL	# ORIGINAL	MODELO	ANCHO	ESPESOR	L./C.	L./L.	BRÍO	BUJE L./C	BUJE L./L
22723-C	-	Pick Up Courier Mod. 2001 / Trasera	60mm	15 mm	23"	27"	5"	1 7/8"	RB-82

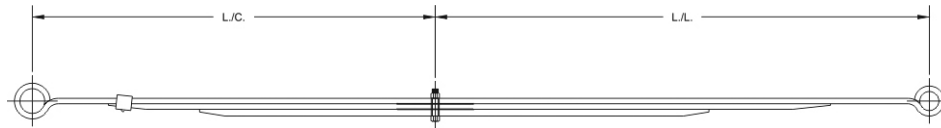

# SANDOVAL	# ORIGINAL	MODELO	ANCHO	ESPEJOR	L./C.	L./L.	BRÍO	BUJE L./C	BUJE L./L
23026-FL	F65A5560AD	Lobo Pick Up Mod. 97-98 / Trasera	2 1/2"	0.360"	26 3/8"	32 1/8"	7 15/16"		
23026-FL1				0.360"	26 3/8"	32 1/8"	7 15/16"	RB-235	RB-236
23026-FL2				0.360"	21 1/2"	25 3/4"	7 15/16"		
23026-FL2RD				0.360"	26 3/8"	32 1/8"	7 15/16"		
23026-FL3				0.447"	26 3/8"	32 1/8"	7/8"		

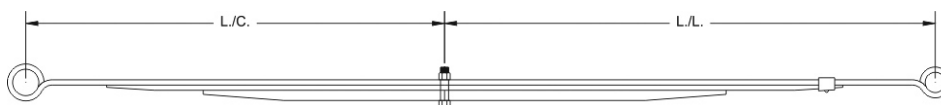

# SANDOVAL	# ORIGINAL	MODELO	ANCHO	ESPEJOR	L./C.	L./L.	BRÍO	BUJE L./C	BUJE L./L
25026-FR	E2TA5560CA	Ranger Mod.86-03 / Trasera	2 1/2"	0.323"	25 1/2"	31"	4"		
25026-FR1				0.323"	25 1/2"	31"		RB-159	RB-120
25026-FR2				0.323"	21"	24 3/4"			
25026-FR2RD				0.323"	25 1/2"	31"			
25026-FR3				0.625"	15"	17 1/2"			

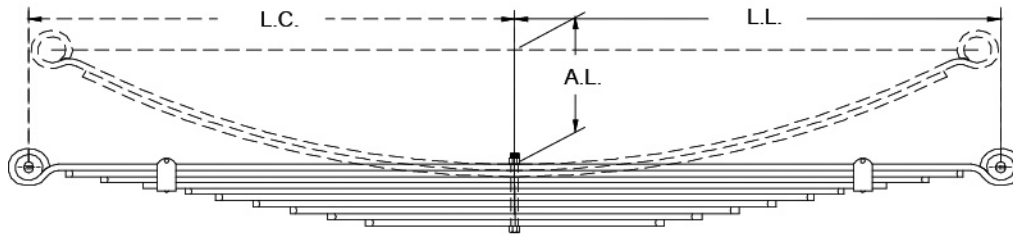

# SANDOVAL	# ORIGINAL	MODELO	ANCHO	ESPESOR	L./C.	L./L.	BRÍO	BUJE L./C	BUJE L./C
26026-C	E7TA5560YA	F350 Doble Roda- do Mod. 92-94 / Trasera	2 1/4"	0.401"	26"	26"	5 1/8"		
26026-C1				0.401"	26"	26"		RB-101	RB-101
26026-C2				0.401"	23 1/2"	23 1/2"			
26026-C2R				0.323"	26"	24 1/2"			
26026-C2RD				0.401"	26 1/8"	26 1/8"			
26026-C3				0.401"	21"	21"			
26026-C4				0.401"	18 3/4"	18 3/4"			
26026-C5				0.401"	16 7/16"	16 7/16"			
26026-C6				0.401"	14 1/16"	14 1/16"			
26026-C7				0.401"	11 13/16"	11 13/16"			
26026-C8				0.401"	9 5/8"	9 5/8"			
26026-C9				0.401"	7 5/16"	7 5/16"			
26026-C10				0.401"	5"	5"			

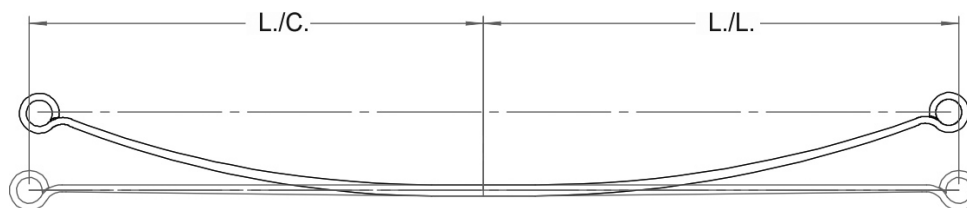

# SANDOVAL	# ORIGINAL	MODELO	ANCHO	ESPESOR	L./C.	L./L.	BRÍO	BUJE L./C	BUJE L./L
28826-FD	-	Transit / Trasera	2 1/2"	0.662"	26 1/4"	27 1/2"	4"	RB-117	RB-40

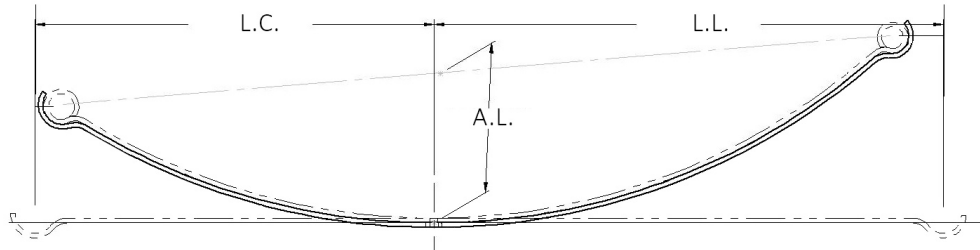

# SANDOVAL	# ORIGINAL	MODELO	ANCHO	ESPESOR	L./C.	L./L.	BRÍO	BUJE L./C	BUJE L./L
30225-FD2RD	-	2da de Refuerzo / Delantera	3"	0.291"	25 1/4"	32 1/4"	9 1/2"	N/A	N/A

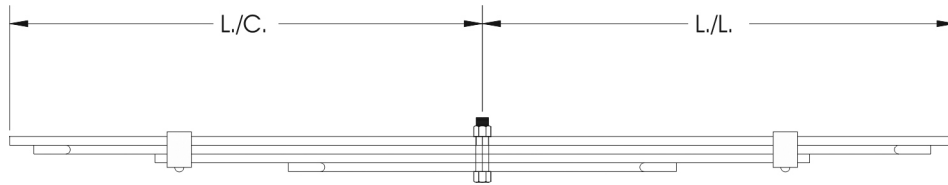

# SANDOVAL	# ORIGINAL	MODELO	ANCHO	ESPESOR	L./C.	L./L.	BRÍO	BUJE L./C	BUJE L./L
33019-A	C2TA5588B	F600, B700, B600 Mod. 62-94 / Trasera	3"	0.360"	19 1/2"	19 1/2"	2 3/4"	N/A	N/A
33019-A1				0.360"	19 1/2"	19 1/2"			
33019-A2				0.360"	18 1/2"	18 1/2"			
33019-A3				0.360"	13 1/2"	13 1/2"			
33019-A4				0.360"	8"	8"			

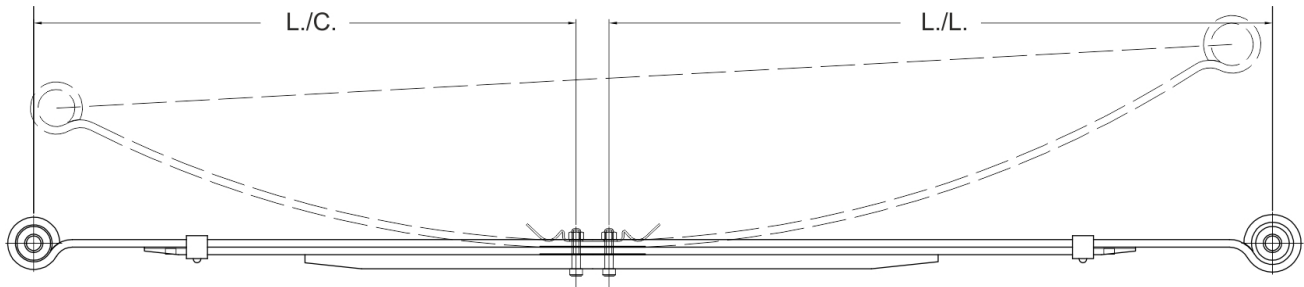

# SANDOVAL	# ORIGINAL	MODELO	ANCHO	ESPEJOR	L./C.	Centro	L./L.	BRÍO	BUJE L./C.	BUJE L./L.
33031-FD	6L3Z556RB	Lobo Trasera 2008	3"	0.360"	25 3/4"	1 9/16"	31 1/2"	7 5/8"	N/A	N/A
33031-FD1				0.360"	25 3/4"	1 9/16"	31 1/2"		RB-275	RB-276
33031-FD2				0.662"	20 1/2"	1 9/16"	25"			
33031-FD2RD		Refuerzo		0.360"	25 3/4"	1 9/16"	31 1/2"			
33031-FD3				0.360"	12 7/8"	1 9/16"	15 5/8"			

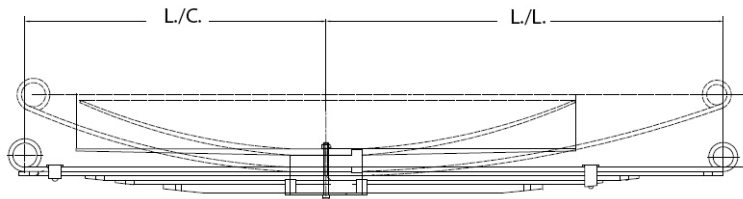

# SANDOVAL	# ORIGINAL	MODELO	ANCHO	ESPEJOR	L./C.	L./L.	BRÍO	BUJE L./C.	BUJE L./L.
33033-FD	-	PICK UP- SUPER DUTY F35050, DIESEL 2005-06	3"	0.360"	25"	33 1/4"	4"	N/A	N/A
33033-FD A1				0.360"	20 3/4"	20 3/4"			
33033-FD1				0.360"	25"	33 1/4"			
33033-FD2				0.360"	25 1/2"	33"			
33033-FD2R				0.360"	25"	33"			
33033-FD3				0.360"	20"	26"			
33033-FD4				0.360"	17 1/2"	23"			
33033-FD5				0.702"	13 1/2"	18"			
ESPACIADOR				0.999"	3"	3"			

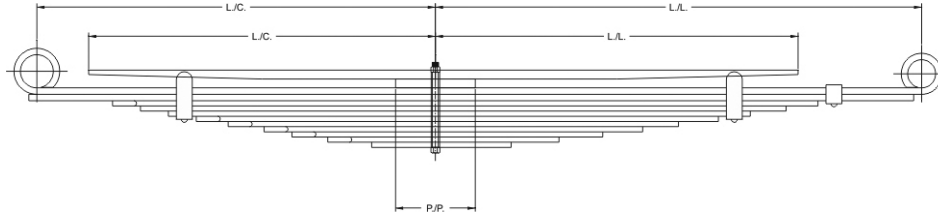

# SANDOVAL	# ORIGINAL	MODELO	ANCHO	ESPESOR	L./C.	L./L.	BRÍO	BUJE L./C	BUJE L./L
34025-F	F81A5560AC	Super Duty, F-450 Mod. 00-03 / Trasera	3"	0.401"	25"	30 1/2"	6 5/16"		
34025-F1				0.401"	25"	30"		RB-245	RB-244
34025-F2				0.401"	25"	30 1/2"			
34025-F2R				0.401"	25"	30 1/2"			
34025-F2RD				0.401"	25"	30 1/2"			
34025-F3				0.323"	20 1/4"	24"			
34025-F3R				0.401"	23"	28"			
34025-F4				0.323"	18 1/2"	22"			
34025-F5				0.323"	16 3/4"	19 3/4"			
34025-F6				0.323"	15"	17 3/4"			
34025-F7				0.323"	13"	15 1/4"			
34025-F8				0.323"	10 3/4"	13"			
34025-F9				0.323"	9"	10 1/2"			
34025-F10				0.323"	6 3/4"	7 3/4"			
34025-F11				0.323"	4"	4 3/4"			

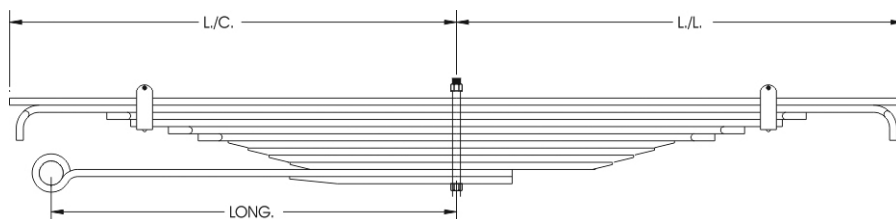

# SANDOVAL	# ORIGINAL	MODELO	ANCHO	ESPESOR	L./C.	L./L.	BRÍO	BUJE L./C	BUJE L./L
34030	C3TA5560AC	B600 C/Tirante Mod. 80-83 / Trasera	3"	0.401"	29 5/8"	29 5/8"	6 5/8"		
34030-1				0.401"	29 5/8"	29 5/8"			
34030-2				0.401"	27 1/16"	27 1/16"			
34030-3				0.401"	23"	23"			
34030-4				0.401"	20 1/2"	20 1/2"			
34030-5				0.401"	18 1/8"	18 1/8"			
34030-6				0.401"	15 3/4"	15 3/4"			
34030-7				0.499"	14 1/8"	14 1/8"			
34030-8				0.499"	10 3/4"	10 3/4"			
34030-9				0.499"	7 3/8"	7 3/8"			
34030-10				0.360"	5 1/2"	5 1/2"			
34030-11				0.447"	25 1/2"	3 1/2"		RNG	
34030-11R				0.447"	25 1/2"	3 1/2"			
34030-12				0.447"	10 1/22"	3"			

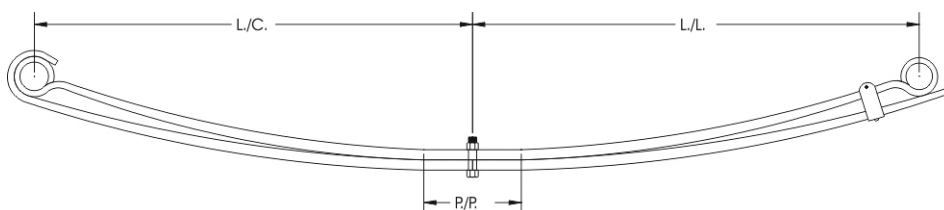

# SANDOVAL	# ORIGINAL	MODELO	ANCHO	ESPESOR	L./C.	L./L.	BRÍO	BUJE L./C	BUJE L./L
36028-FD	F81Z5310AF, F81A5310AGD	Super Duty 450, 550 Mod. 99-00 / Delantera	3"	0.625"	27 1/2"	28"	4 1/2"		
36028-FD1				0.625"	27 1/2"	28"		RB-243	RB-244
36028-FD2				0.625"	27 1/2"	30"			
36028-FD3E				0.625"	28 1/2"	30"			

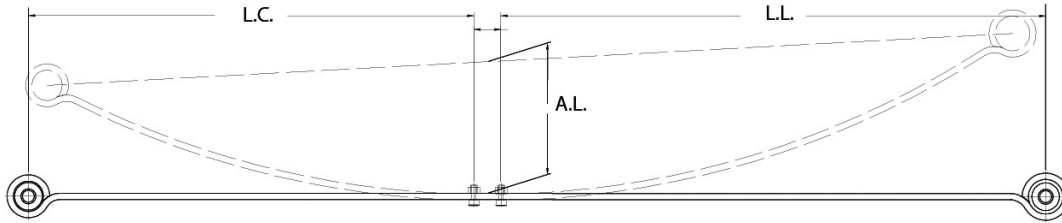

# SANDOVAL	# ORIGINAL	MODELO	ANCHO	ESPEJOR	L./C.	CENTRO	L./L.	BRÍO	BUJE L./C	BUJE L./L
35125-FD	-	Lobo Mod. 04-05 / Trasera	3"	0.323"	25 1/2"	1 9/16"	31 1/4"	7"	RB-73	RB-133
35225-FD2RD				0.323"	25 1/2"	1 9/16"	31 1/4"	7"		

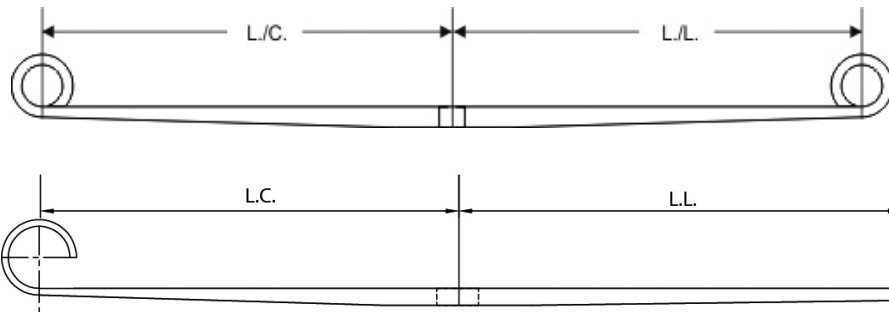

# SANDOVAL	# ORIGINAL	MODELO	ANCHO	ESPEJOR	L./C.	L./L.	BRÍO	BUJE L./C	BUJE L./L
36128-E	-	Heavy Duty Mod. 02-03 / Delantera	3"	0.625"	27 1/2"	28"	5 1/8"	RB-245	RB-244
36228-E				0.625"	27 1/2"	28"	5 1/8"		

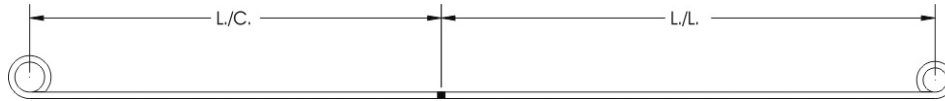

# SANDOVAL	# ORIGINAL	MODELO	ANCHO	ESPESOR	L./C.	L./L.	BRÍO	BUJE L./C	BUJE L./L
43-1265-1	F81A5560DB	Super Duty 350 Triton Mod. 99-04 / Trasera	3"	0.401"	25 1/2"	30 1/4"	5 3/8"	RB-155	RB159

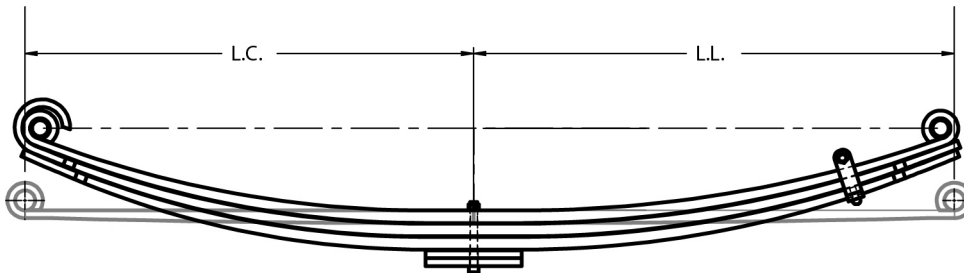

# SANDOVAL	# ORIGINAL	MODELO	ANCHO	ESPESOR	L./C.	L./L.	BRÍO	BUJE L./C	BUJE L./L
43-620	F3HT5310VA	Ford Truck	4"	0.788"	28"	30"	5 1/8"		
43-620-1			4"	0.788"	28"	30"		1 1/4"	1 1/4"
43-620-2			4"	0.788"	28"	31"			
43-620-3			4"	0.788"	29"	31"			

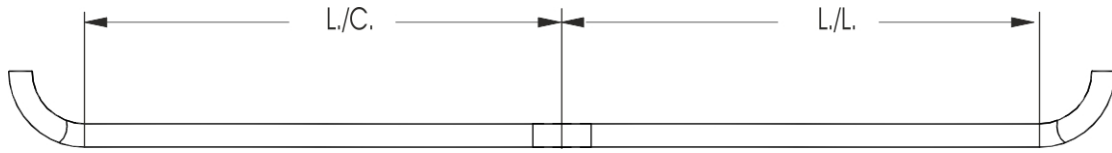

# SANDOVAL	# ORIGINAL	MODELO	ANCHO	ESPEJOR	L./C.	L./L.	BRÍO	BUJE L./C	BUJE L./L
43-1265-2RD	F81A5560DB	Super Duty 350 Triton Mod. 99-04 / Trasera	3"	0.401"	25 3/4"	30 1/2"	5 31/32"	RB-204	RB-204

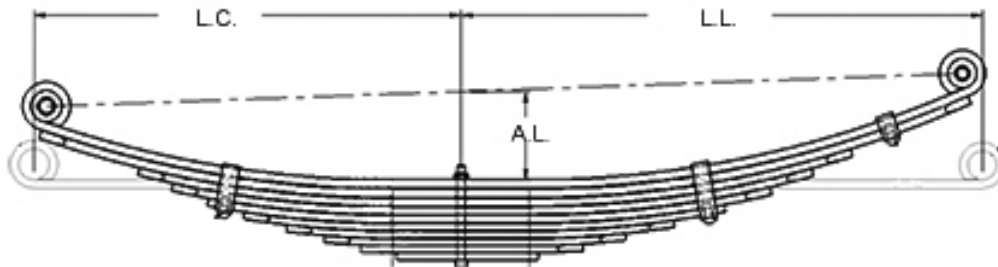

# SANDOVAL	# ORIGINAL	MODELO	ANCHO	ESPEJOR	L./C.	L./L.	BRÍO	BUJE L./C	BUJE L./L
43-1289	F81Z5560BB	Camión E550 Mod. 2002-2003 / Trasera	3"	0.499"	25"	30 1/2"	5 1/8"		
43-1289-1				0.499"	25"	30 1/2"		8150	8150
43-1289-2				0.499"	25"	30 1/2"			
43-1289-3				0.447"	19"	23 1/8"			
43-1289-4				0.447"	17"	20 3/4"			
43-1289-5				0.447"	14 7/8"	18 1/4"			
43-1289-6				0.401"	12 3/4"	15 1/2"			
43-1289-7				0.401"	10 1/4"	12 1/2"			
43-1289-8				0.401"	8"	9 5/8"			
43-1289-9				0.401"	5 7/8"	7 1/8"			
43-1289-10				0.401"	4"	4 1/2"			

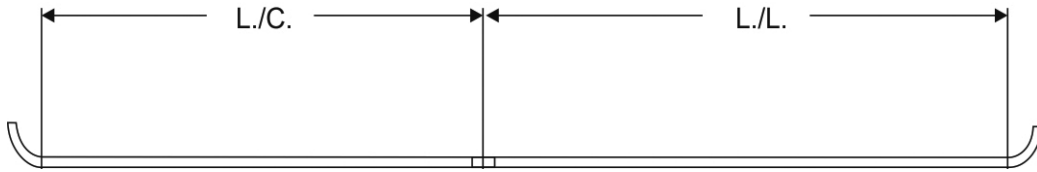

# SANDOVAL	# ORIGINAL	MODELO	ANCHO	ESPESOR	L./C.	L./L.	BRÍO	BUJE L./C.	BUJE L./L.
43-1289HD-2RD	-	Super Duty Mod. 2010 / Trasera	3"	0.558"	25 1/4"	30 3/4"	5 7/8"	N/A	N/A

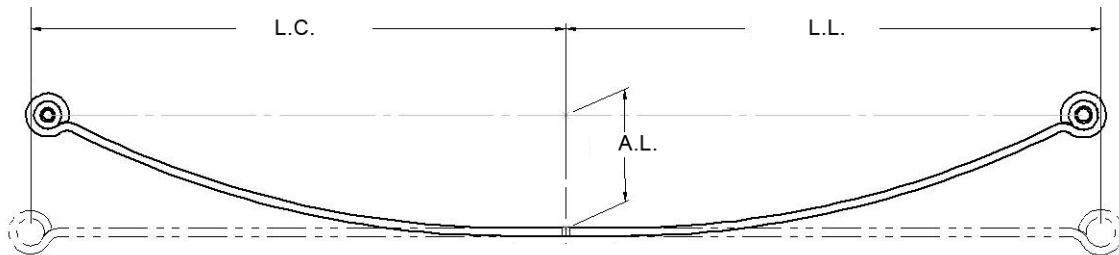

# SANDOVAL	# ORIGINAL	MODELO	ANCHO	ESPESOR	L./C.	L./L.	BRÍO	BUJE L./C.	BUJE L./L.
43-1855	BC375560E	Truck Mod. 2015 / Trasera	3"	0.499"	33 1/4"	33 1/4"	7"		
43-1855-1					33 1/4"	33 1/4"	7"	RB-244	RB-243
43-1855-2					28 1/4"	28 1/4"	5"		
43-1855-2RD					33 1/4"	33 1/4"	6 1/2"		
43-1855-3					18"	18"	-		

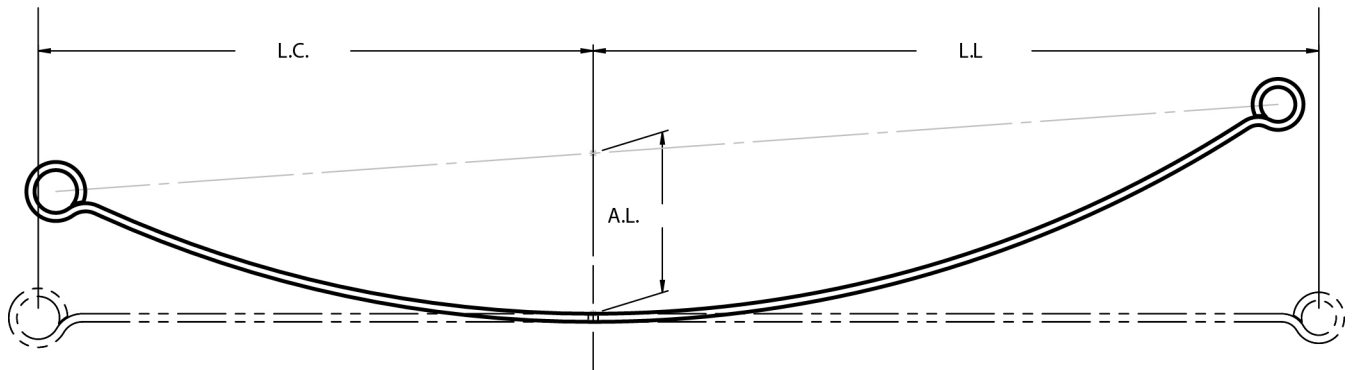

# SANDOVAL	# ORIGINAL	MODELO	ANCHO	ESPEJOR	L./C.	L./L.	BRÍO	BUJE L./C	BUJE L./L
FD-0004-1	-	PICK UP SUPER DUTY AMERICANA	3"	0.380"	26"	34"	7 1/2"	RB-227	RB-158R

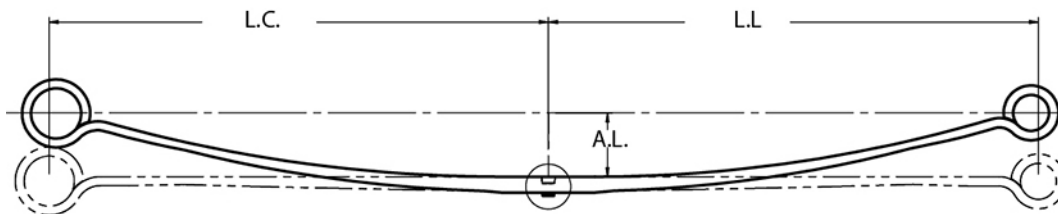

# SANDOVAL	# ORIGINAL	MODELO	ANCHO	ESPEJOR	L./C.	L./L.	BRÍO	BUJE L./C	BUJE L./L
FD-0005-1	FK21-5560-AA	-	60 mm	22 mm	27 3/8"	26 7/8"	3 1/2"	2 3/4"	1.969"

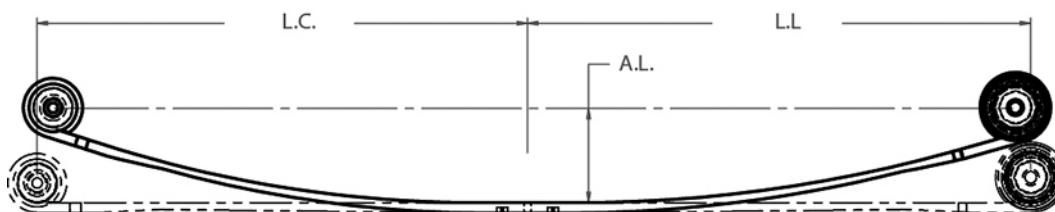

# SANDOVAL	# ORIGINAL	MODELO	ANCHO	ESPESOR	L./C.	L./L.	BRÍO	BUJE L./C	BUJE L./L
FD-0006-1	-	FORD TRANSIT 2012-2015	3"	0.558"	26 5/8"	27 5/16"	5 1/8"	RB-362	RB-361

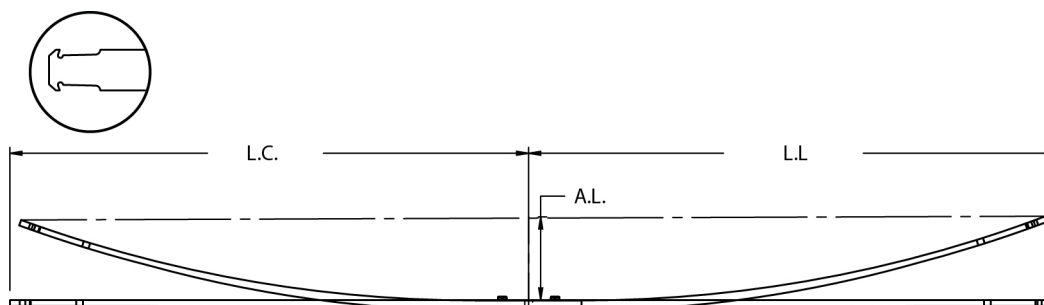

# SANDOVAL	# ORIGINAL	MODELO	ANCHO	ESPESOR	L./C.	L./L.	BRÍO	BUJE L./C	BUJE L./L
FD-0006-2	-	FORD TRANSIT 2012-2015	3"	0.558"	27"	27 1/2"	4 5/16"	N/A	N/A

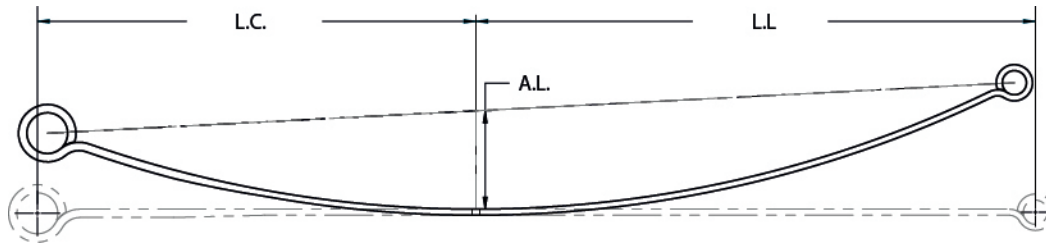

# SANDOVAL	# ORIGINAL	MODELO	ANCHO	ESPESOR	L./C.	L./L.	BRÍO	BUJE L./C	BUJE L./L
FD-0007-1	-	FORD RANGER 2016	60 mm	11 mm	580 mm	740 mm	130 mm		

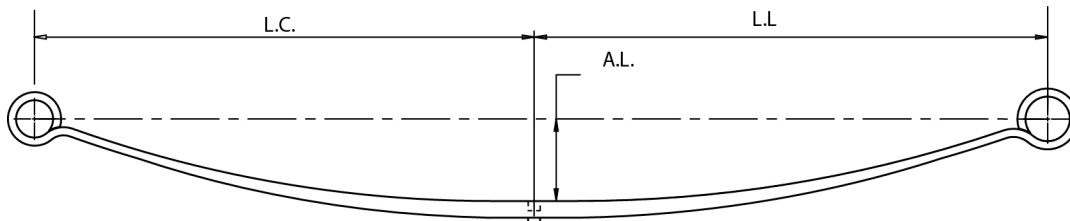

# SANDOVAL	# ORIGINAL	MODELO	ANCHO	ESPESOR	L./C.	L./L.	BRÍO	BUJE L./C	BUJE L./L
FD-0010-1	-	FORD TRANSIT 2016-2017	60 mm	22 mm	26 5/8"	27 1/4"	4.25"	1 15/16"	2 5/16"

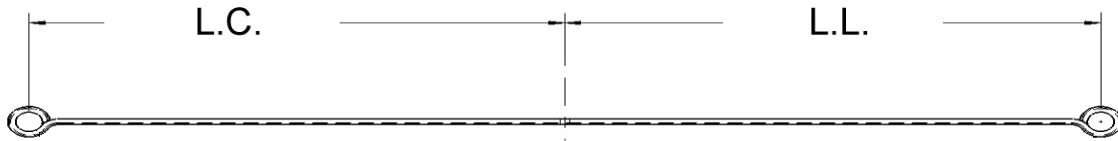

# SANDOVAL	# ORIGINAL	MODELO	ANCHO	ESPEJOR	L./C.	L./L.	BRÍO	BUJE L./C	BUJE L./L
FN-0001	-	Foton -Mod. 2015	2.937"	0.401"	27 1/2"	27 1/2"	5 1/2"	1 3/8"	1 3/8"

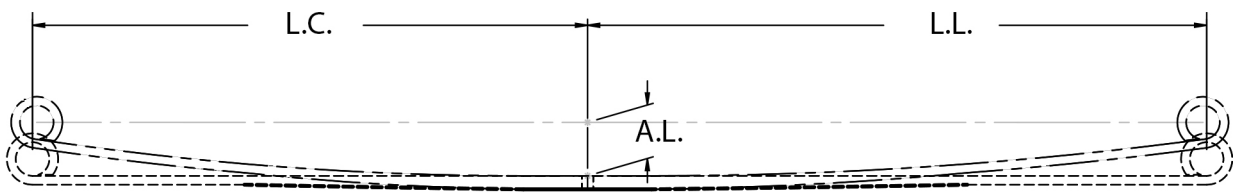

# SANDOVAL	# ORIGINAL	MODELO	ANCHO	ESPEJOR	L./C.	L./L.	BRÍO	BUJE L./C	BUJE L./L
FN-0002-1	-	Foton, Mod. 2015 / Delantera	90mm	16 mm	26"	29"	2 1/2"	1.575"	1.575"

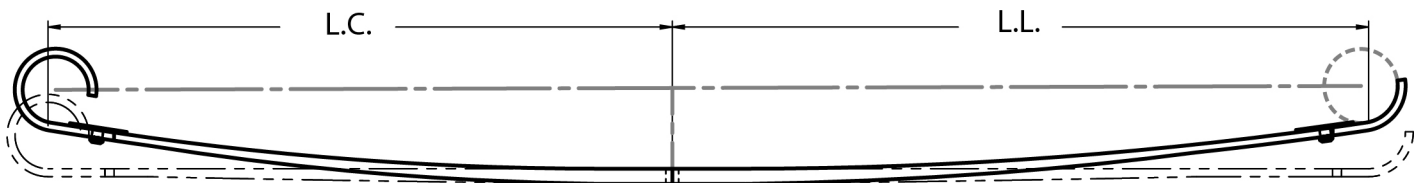

# SANDOVAL	# ORIGINAL	MODELO	ANCHO	ESPEJOR	L./C.	L./L.	BRÍO	BUJE L./C	BUJE L./L
FN-0002-2	-	Foton Mod. 2015 / Delantera	90mm	16 mm	26"	29"	3 3/8"	N/A	N/A

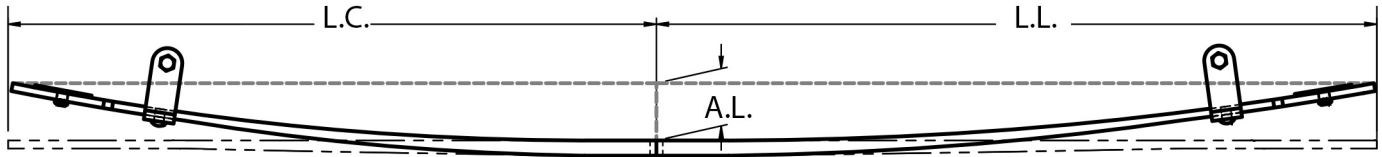

# SANDOVAL	# ORIGINAL	MODELO	ANCHO	ESPESOR	L./C.	L./L.	BRÍO	BUJE L./C	BUJE L./L
FN-0002-3	-	Foton, Mod. 2015 / Delantera	90mm	16 mm	27"	30"	2 3/8"	N/A	N/A

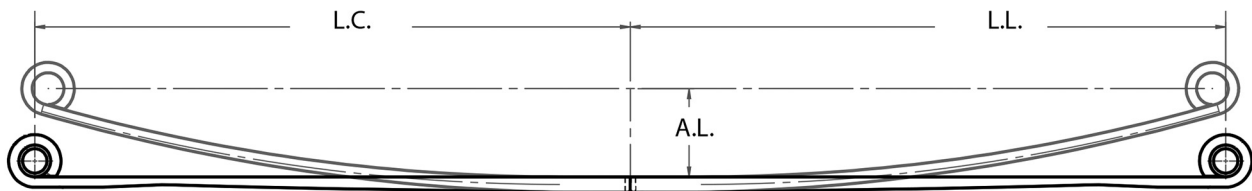

# SANDOVAL	# ORIGINAL	MODELO	ANCHO	ESPESOR	L./C.	L./L.	BRÍO	BUJE L./C	BUJE L./L
FN-0003-1	1681129520010	Foton, Mod. 2015 / Trasera	4"	0.788"	30 1/2"	30 1/2"	4 1/2"	1 5/8"	1 5/8"

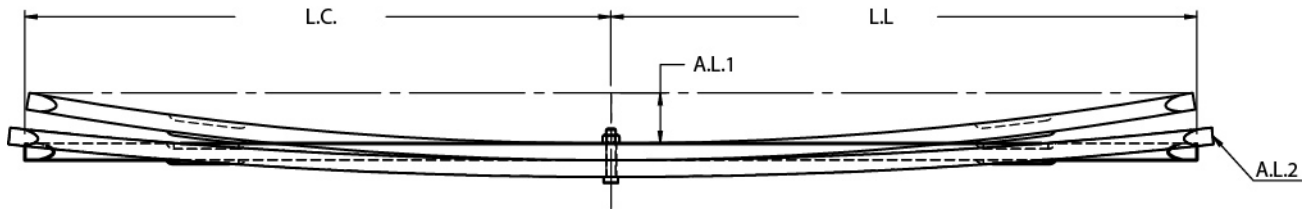

# SANDOVAL	# ORIGINAL	MODELO	ANCHO	ESPESOR	L./C.	L./L.	BRÍO	BUJE L./C	BUJE L./L
FN-0004	-	-	90 mm	22 mm	30 1/2"	30 1/2"			
FN-0004-1				22 mm	30 1/2"	30 1/2"	2 5/8"	N/A	N/A
FN-0004-2				22 mm	31 3/8"	31 3/8"	1 11/16"		

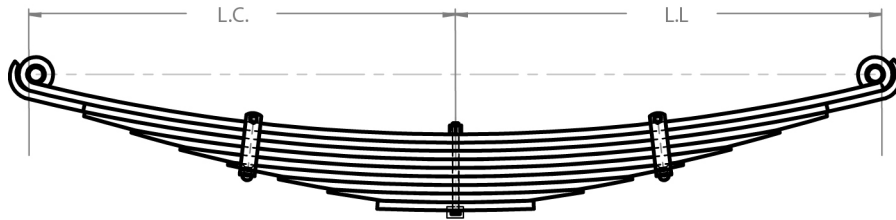

# SANDOVAL	# ORIGINAL	MODELO	ANCHO	ESPESOR	L./C.	L./L.	BRÍO	BUJE L./C	BUJE L./L
FN-0005	-	-	90 mm	18 mm	35 1/2"	35 1/2"	5"		
FN-0005-1				18 mm	35 1/2"	35 1/2"		BB-RMI	BB-RMI
FN-0005-3				18 mm	31 3/8"	31 3/8"			

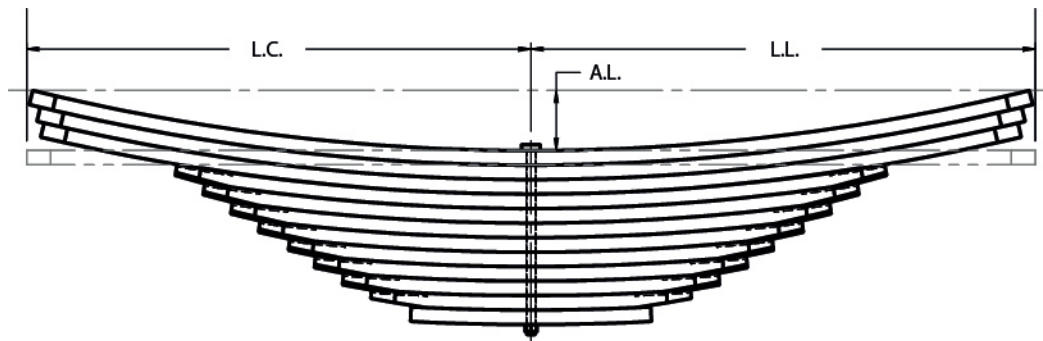

# SANDOVAL	# ORIGINAL	MODELO	ANCHO	ESPESOR	L./C.	L./L.	BRÍO	BUJE L./C	BUJE L./L
FN-0006		Trasera	3.543"	0.905"	31 1/2"	31 1/2"	3 3/4"	N/A	N/A
FN-0006-1			3.543"	0.905"	31 1/2"	31 1/2"			
FN-0006-2			3.543"	0.905"	31"	31			
FN-0006-3			3.543"	0.905"	30 3/4"	30 3/4"			
FN-0006-4			3.543"	0.905"	22 1/4"	22 1/4"			
FN-0006-5			3.543"	0.905"	20 1/2"	20 1/2"			
FN-0006-6			3.543"	0.905"	18 3/4"	18 3/4"			
FN-0006-7			3.543"	0.905"	17 "	17"			
FN-0006-8			3.543"	0.905"	15 1/8"	15 1/8"			
FN-0006-9			3.543"	0.905"	13 1/2"	13 1/2"			
FN-0006-10			3.543"	0.905"	11 3/4"	11 3/4"			
FN-0006-11			3.543"	0.905"	10 "	10"			
FN-0006-12			3.543"	0.905"	7 1/2"	7 1/2"			

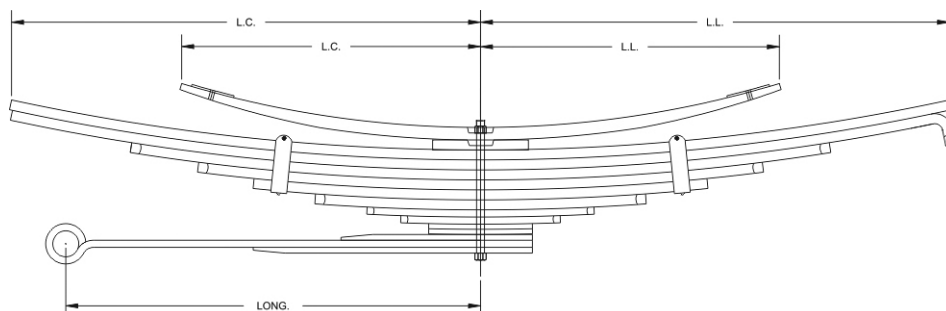

# SANDOVAL	# ORIGINAL	MODELO	ANCHO	ESPESOR	L./C.	L./L.	BRÍO	BUJE L./C	BUJE L./L
36030-F	6803200205	Revolvedora Mod. 96 / Trasera	3"	0.625"	29 5/8"	29 5/8"	3 1/8"		
36030-F1				0.625"	29 5/8"	29 5/8"			
36030-F2				0.625"	29 5/8"	29"			
36030-F3				0.625"	21 3/4"	22"			
36030-F4				0.625"	17 3/4"	17 3/4"			
36030-F5				0.625"	14 1/4"	14 1/4"			
36030-F6				0.625"	10 3/8"	10 3/8"			
36030-F7				0.447"	7 1/8"	7 1/8"			
36030-F8				0.447"	5"	5"			
36030-F9				0.323"	3 1/4"	3 1/4"			
36030-F10				0.323"	3 1/4"	3 1/4"		1 5/8"	
36030-F11				0.360"	8 3/4"	3 1/4"			
36030-F12				0.447"	26"	3 1/4"			
36030-F13				0.360"	14 1/4"	3 1/4"			

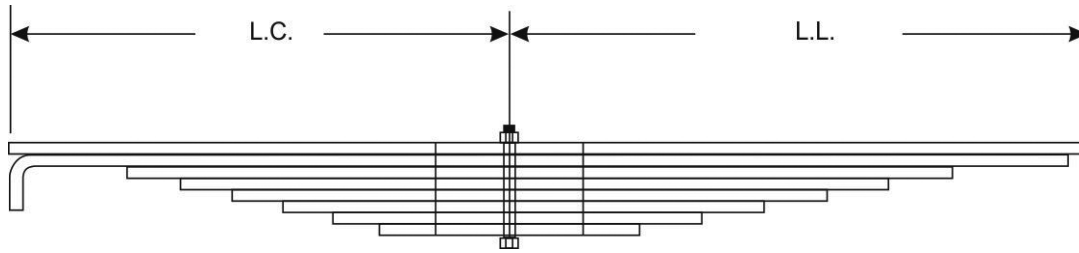

# SANDOVAL	# ORIGINAL	MODELO	ANCHO	ESPEJOR	L./C.	L./L.	BRÍO	BUJE L./C	BUJE L./L
38022-FL	6813201305	Serie FH, FL, FR, FRG, FS, FSG Mod. 1988-97 / Trasera	3"	0.558"	22"	25 1/2"	3 5/8"		
38022-FL1				0.558"	22"	25 1/2"			
38022-FL2				0.558"	22"	24 11/16"			
38022-FL3				0.558"	16 3/4"	19 1/2"			
38022-FL4				0.499"	14 1/2"	16 3/4"			
38022-FL5				0.499"	12 1/4"	14"			
38022-FL6				0.499"	10"	11 1/4"			
38022-FL7				0.499"	7 3/4"	8 1/2"			
38022-FL8				0.499"	5 3/4"	5 3/4"			

* Imagen no disponible

# SANDOVAL	# ORIGINAL	MODELO	ANCHO	ESPEJOR	L./C.	L./L.	BRÍO	BUJE L./C	BUJE L./L
38030-FL	6803200205	Revolvedora Mod. 96-97 / Trasera	3"	0.558"	30"	30"	6"		
38030-FL1				0.558"	30"	30"			
38030-FL2				0.558"	30"	30"			
38030-FL3				0.558"	27"	27"			
38030-FL4				0.558"	24"	24"			
38030-FL5				0.558"	21"	21"			
38030-FL6				0.558"	18"	18"			
38030-FL7				0.558"	15"	15"			

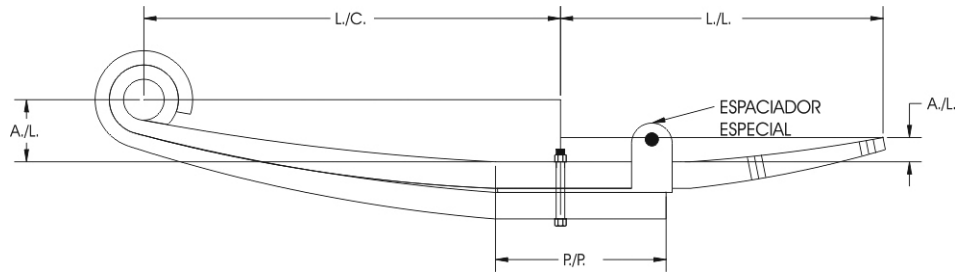

# SANDOVAL	# ORIGINAL	MODELO	ANCHO	ESPESOR	L./C.	L./L.	BRÍO	BUJE L./C	BUJE L./L
38926-F	A1613997000	Susp. Aire Mod. 2001 / Trasera	3"	1 5/8"	26"	20"	L.C. 1 3/4 L.L. 3 1/2		
38926-F1				1 5/8"	26"	20"		RB-268	
38926-F2				1 5/8"	26"	6 1/2"			

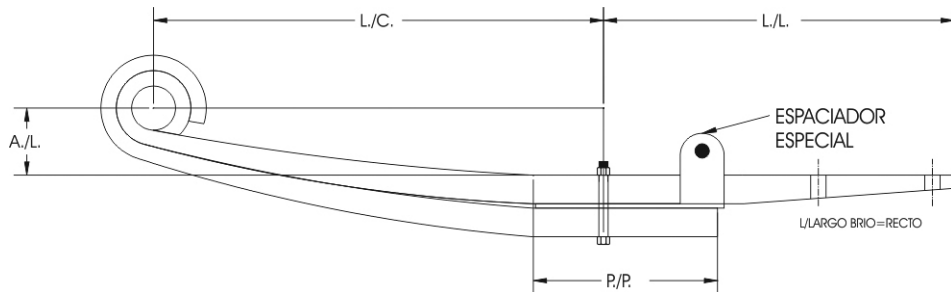

# SANDOVAL	# ORIGINAL	MODELO	ANCHO	ESPESOR	L./C.	L./L.	BRÍO	BUJE L./C	BUJE L./L
38926-FG	A1616414001	Susp. Aire Mod. 2001 / Trasera	3"	1 5/8"	26"	20"	L.C. 3 1/2		
38926-FG1				1 5/8"	26"	20"		RB-268	
38926-FG2				1 5/8"	26"	6 1/2"			

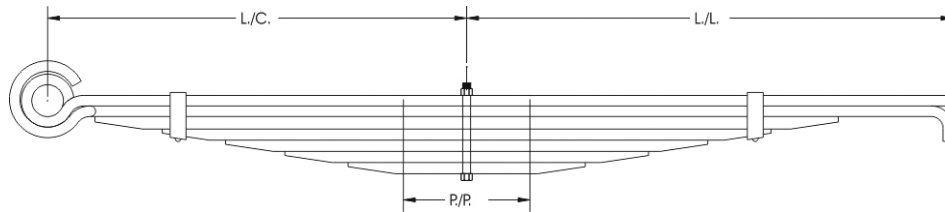

# SANDOVAL	# ORIGINAL	MODELO	ANCHO	ESPESOR	L./C.	L./L.	BRÍO	BUJE L./C	BUJE L./L
39626-FL	A161633800	FL70-80 Mod. 05-06 / Trasera	3"	0.662"	26 1/8"	30 3/4"	3 7/8"		
39626-FL1				0.662"	26 1/8"	30 3/4"		RB-267/ RB-135	
39626-FL2				0.662"	26 1/8"	30 1/8"			
39626-FL3				0.788"	23 1/2"	23 1/2"			
39626-FL4				0.702"	19 5/16"	19 5/16"			
39626-FL5				0.702"	15 5/16"	15 5/16"			
39626-FL6				0.702"	11 5/16"	11 5/16"			
39626-FL7				0.702"	7 5/16"	7 5/16"			

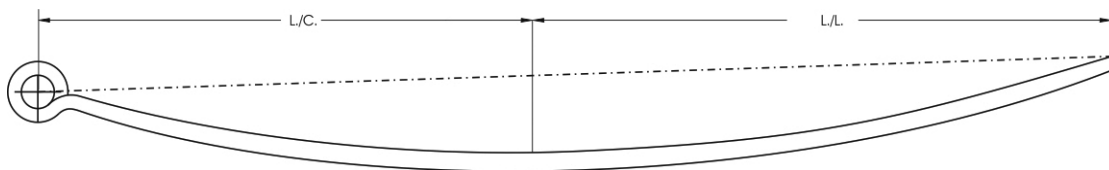

# SANDOVAL	# ORIGINAL	MODELO	ANCHO	ESPESOR	L./C.	L./L.	BRÍO	BUJE L./C	BUJE L./L
39626HD-FL1	A1613997000	Class M2 Mod. 2005 / Trasera	3"	0.788"	26 1/8"	30 3/4"	3 7/8"	RB-267/ RB-135	

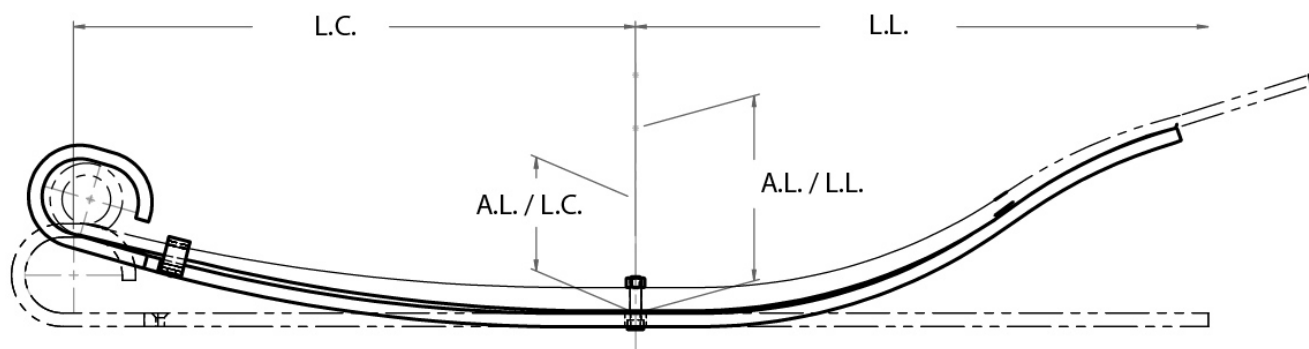

# SANDOVAL	# ORIGINAL	MODELO	ANCHO	ESPESOR	L./C.	L./L.	BRÍO	BUJE L./C	BUJE L./L
39633-FL	A161678700	Class M2 Mod. 2005 / Delantera	3"	0.625"	26"	33"	LC 4 1/2" LL 9 3/16"		
39633-FL1					26"	33"		RB-212	
39633-FL2					26"	3"			
39633-FLR					26"	26 1/2"			

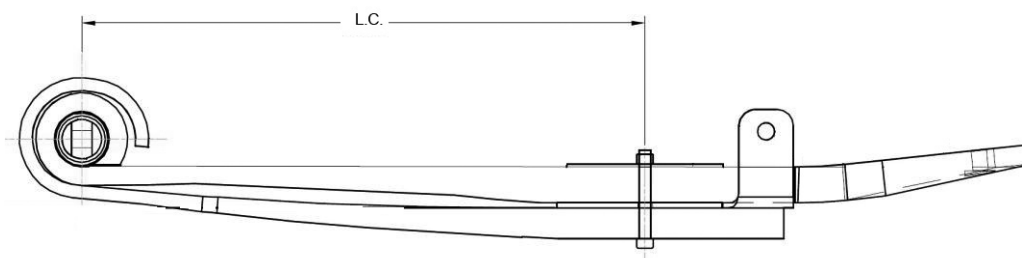

# SANDOVAL	# ORIGINAL	MODELO	ANCHO	ESPESOR	L./C.	L./L.	BRÍO	BUJE L./C	BUJE L./L
46-1211-1	A1613999000	Palo de Hockey Izq. Mod. 1995 / Trasera	3"	1 3/8"	25 19/32"	18 1/2"	L.C. 1"	RB-268	
46-1211-2			3"	1 3/8"	25 19/32"	6 9/32"	L.L. 3 1/8"		
46-1213-1	A1613999001	Palo de Hockey Der. / Trasera	3"	1 3/8"	25 19/32"	18 1/2"	L.C. 1"	RB-268	
46-1213-2			3"	1 3/8"	25 19/32"	6 9/32"	L.L. 3 1/8"		

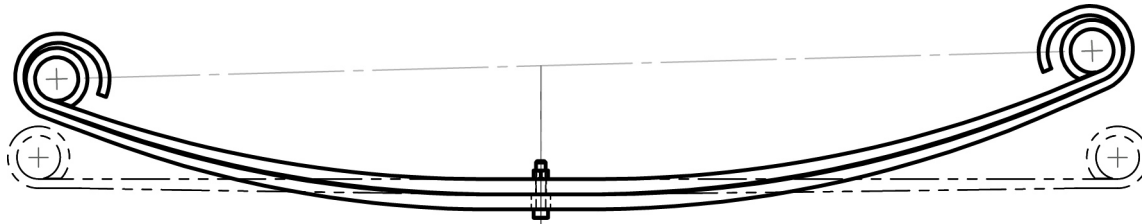

# SANDOVAL	# ORIGINAL	MODELO	ANCHO	ESPESOR	L./C.	L./L.	BRÍO	BUJE L./C	BUJE L./L
46-1302	-	-	4"	0.788"	26 1/8"	30"	5 7/8"		
46-1302-1		-	4"	0.788"	26 1/8"	30"	L.L. 3 1/8"	2 1/4"	2 1/4"
46-1302-2	-	-	4"	0.788"	26 1/8"	30"	L.C. 1"		

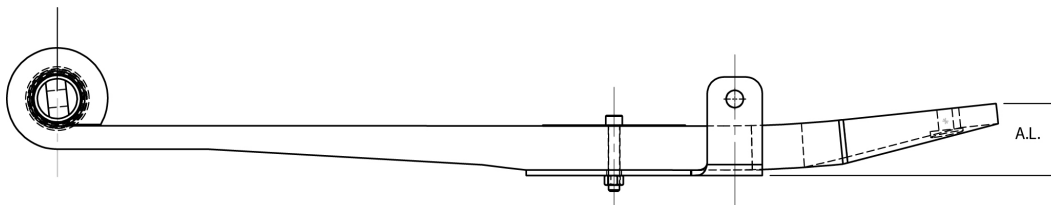

# SANDOVAL	# ORIGINAL	MODELO	ANCHO	ESPESOR	L./C.	L./L.	BRÍO	BUJE L./C	BUJE L./L
46-1345	A16-16413-000	Izquierda	75.4 mm	50.8 mm	644 mm	470 mm	73 mm	RB-268	-
46-1347	A16-16413-001	Derecha	75.4 mm	50.8 mm	644 mm	470 mm	73 mm	RB-268	-

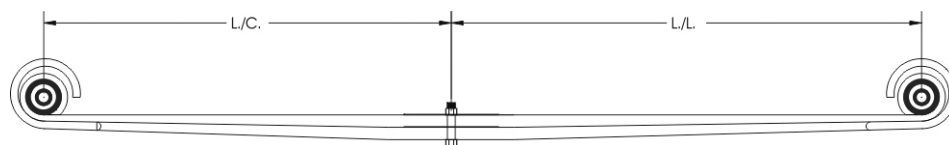

# SANDOVAL	# ORIGINAL	MODELO	ANCHO	ESPESOR	L./C.	L./L.	BRÍO	BUJE L./C	BUJE L./L
46-1434	A1614602000	Mod. 2005-2010/ Delantera	4"	0.788"	26"	30"	6 1/8"		
46-1434-1				0.788"	26"	30"		RB-263	RB-233
46-1434-2				0.788"	26 3/16"	30 1/4"			

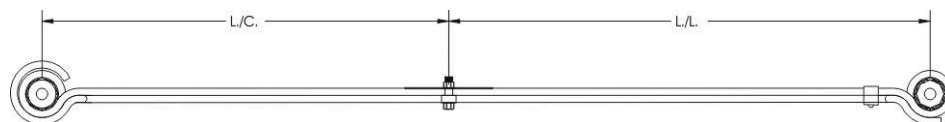

# SANDOVAL	# ORIGINAL	MODELO	ANCHO	ESPESOR	L./C.	L./L.	BRÍO	BUJE L./C	BUJE L./L
47128-P	LM6853203802	Adaptación Especial Mod. 94- 00 / Delantera	4"	0.447"	28"	33"	5"	RB-211/ RB-233	RB-211/ RB-233
47228-P				0.447"	28"	33"	5"		

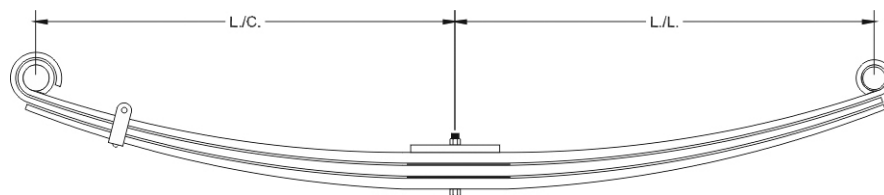

# SANDOVAL	# ORIGINAL	MODELO	ANCHO	ESPESOR	L./C.	L./L.	BRÍO	BUJE L./C	BUJE L./L
48026	A1612612	Tracto Camión Mod. 91-94 / Delantera	4"	0.662"	26"	29"	3"		
48026-1				0.662"	26"	29"		BM-RNK	BM-RNK
48026-2				0.662"	26"	30"			
48026-3				0.662"	27"	30"			
PAD				0.401"	3"	3"			

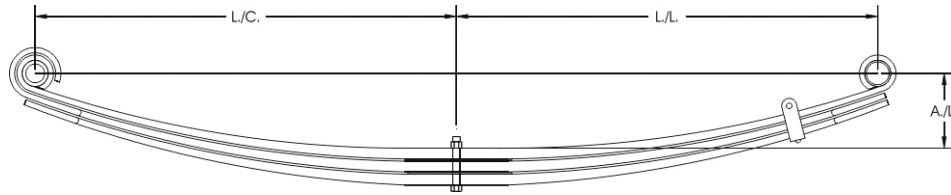

# SANDOVAL	# ORIGINAL	MODELO	ANCHO	ESPESOR	L./C.	L./L.	BRÍO	BUJE L./C	BUJE L./L
48026-M	A1613412001	Tracto Camión Mod. 84-00 / Delantera	4"	0.788"	26"	29"	6 1/2"		
48026-M1				0.788"	26"	29"		RNK	RNK
48026-M2				0.788"	26"	30"			
48026-M3				0.788"	27"	30"			

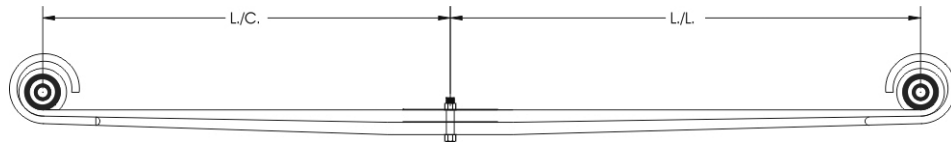

# SANDOVAL	# ORIGINAL	MODELO	ANCHO	ESPESOR	L./C.	L./L.	BRÍO	BUJE L./C	BUJE L./L
49026-FG	A1614463000	FL112 Mod. 96-00 / Delantera	4"	0.788"	26"	30"	5 7/8"		
49026-FG1				0.788"	26"	30"		RB-233R/211R	RB-233R/211R
49026-FG2				0.788"	26"	30"			

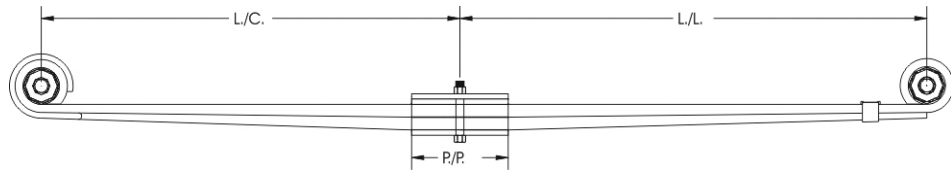

# SANDOVAL	# ORIGINAL	MODELO	ANCHO	ESPESOR	L./C.	L./L.	BRÍO	BUJE L./C	BUJE L./L
49026-FL	FH2300014	Tracto Camión Mod. 2003 / Delantera	4"	0.788"	26"	29"	4 1/2"		
49026-FL01				0.323"	3"	3"			
49026-FL02				0.323"	3"	3"			
49026-FL1				0.788"	26"	29"		RB-233	RB-233
49026-FL2				0.788"	26"	29"			
49026-FL03				0.323"	3"	3"			

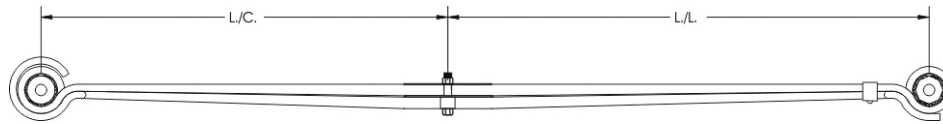

# SANDOVAL	# ORIGINAL	MODELO	ANCHO	ESPESOR	L./C.	L./L.	BRÍO	BUJE L./C	BUJE L./L
49128-P	6803200302	FLT80 Mod. 94-00 / Delantera	4"	0.788"	28"	32 3/4"	5 1/2"	RB-211/ RB-233	RB-211/ RB-233
49228-P				0.788"	28"	32 3/4"			

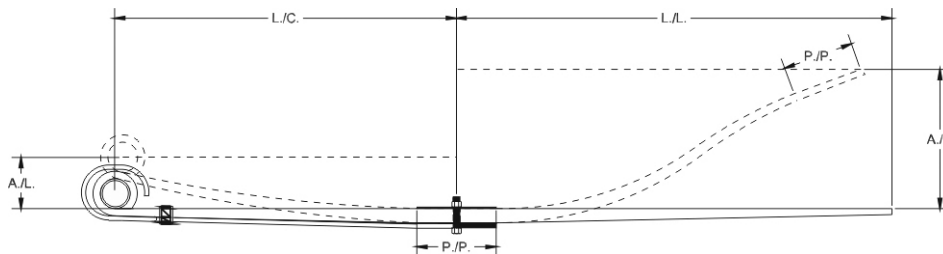

# SANDOVAL	# ORIGINAL	MODELO	ANCHO	ESPESOR	L./C.	L./L.	BRÍO	BUJE L./C	BUJE L./C
50025-FL	A1616789000	Bussines Class Mod. 2005 / Delantera	4"	0.999"	25 7/8"	33"	L.C. 3 7/8 L.L. 10 1/2		
50025-FL1				0.999"	25 7/8"	33"		RB-211	
50025-FL2				0.323"	25 7/8"	3"			

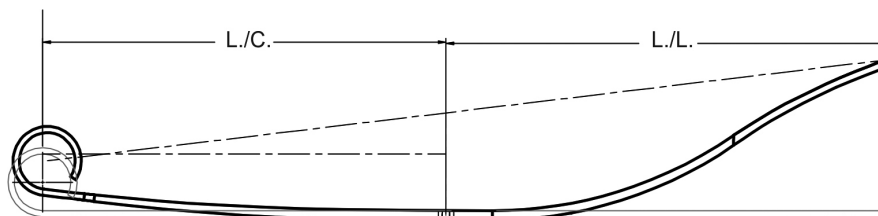

# SANDOVAL	# ORIGINAL	MODELO	ANCHO	ESPESOR	L./C.	L./L.	BRÍO	BUJE L./C	BUJE L./L
50025-FLR	A1616789000	Bussines Class Mod.2005 / De- lantera	4"	0.625"	25 7/8"	28 1/2"	L.C. 3 7/8 L.L. 10 1/2	3 5/8"	

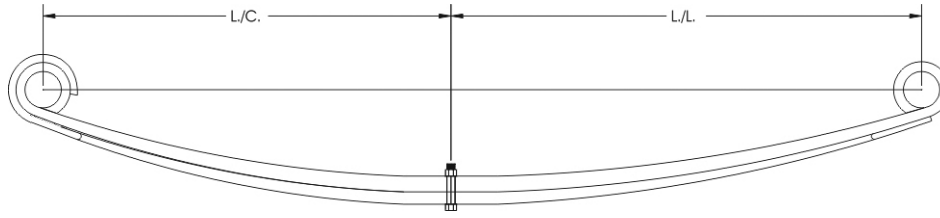

# SANDOVAL	# ORIGINAL	MODELO	ANCHO	ESPEJOR	L./C.	L./L.	BRÍO	BUJE L./C	BUJE L./L
50026-F	A1614898000	FL112 Columbia 120 Mod. 2000 / Delantera	4"	0.999"	26"	30"	5 1/2"		
50026-F1				0.999"	26"	30"		RB-233R	RB-233R
50026-F2				0.788"	26"	31"			

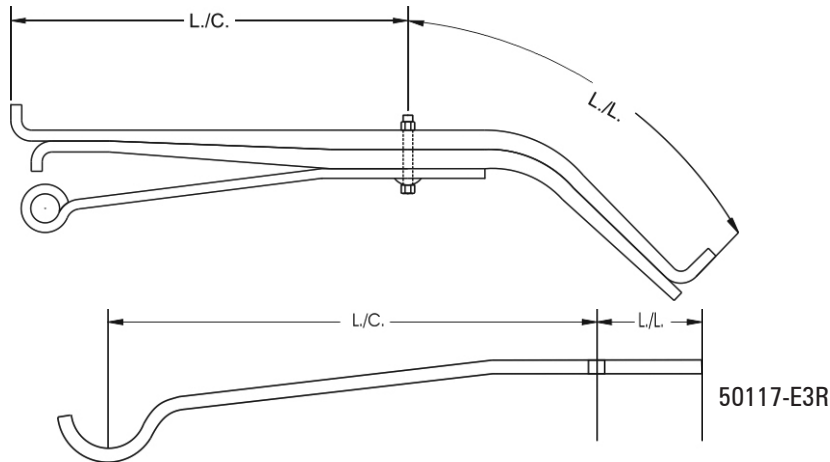

# SANDOVAL	# ORIGINAL	MODELO	ANCHO	ESPEJOR	L./C.	L./L.	BRÍO	BUJE L./C	BUJE L./L
50117-E	A1612852	Servicio Pesado Bolsa de Aire Mod. 89 / Trasera	4"	0.999"	20 5/8"	17"	5 1/2"		
50117-E1				0.999"	26"	29"			
50117-E2				0.999"	19 9/16"	17"			
50117-E3				0.499"	18 5/8"	4"		RB-175	
50117-E3G				0.499"	21 11/16"	4"			
50117-E3R				0.499"	18 5/8"	4"			

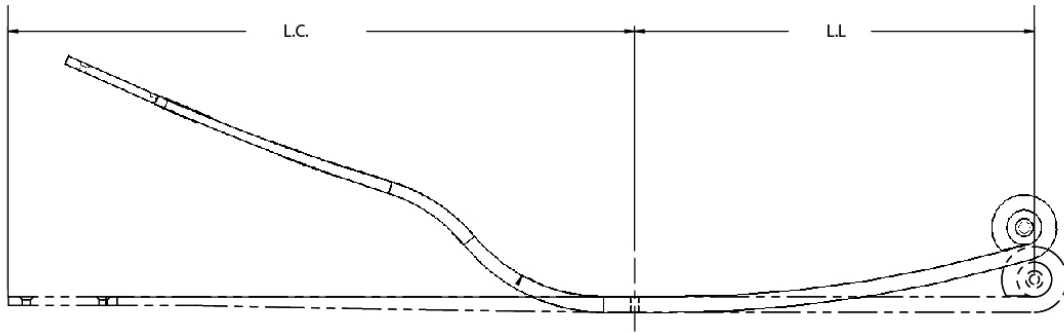

# SANDOVAL	# ORIGINAL	MODELO	ANCHO	ESPESOR	L./C.	L./L.	BRÍO	BUJE L./C	BUJE L./L
FL-0001	-	DELANTERA	3"	0.999"	40 3/4"	26"	15 5/8"	RB-263	N/A

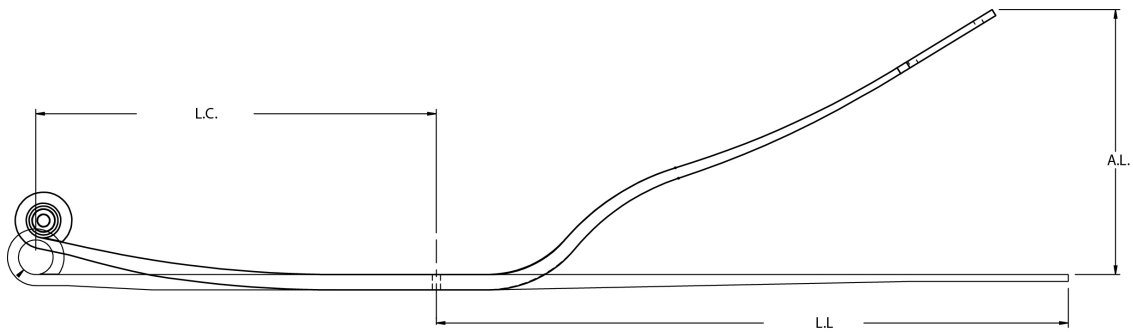

# SANDOVAL	# ORIGINAL	MODELO	ANCHO	ESPESOR	L./C.	L./L.	BRÍO	BUJE L./C	BUJE L./L
FL-0002-1	-	-	3"	0.999"	26 1/16"	41 1/8"	17 1/4"	RB-233	

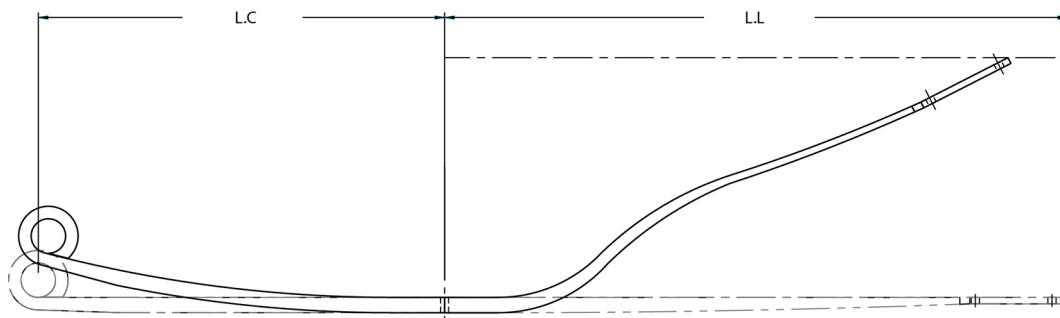

# SANDOVAL	# ORIGINAL	MODELO	ANCHO	ESPESOR	L./C.	L./L.	BRÍO	BUJE L./C	BUJE L./L
FL-0003	HDR59930-30	Airtek delantera	3"	0.999"	26 1/2"	40 5/8"	4"/15 5/8"	2 1/4"	

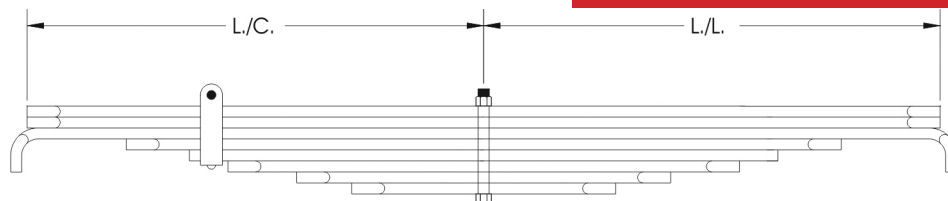

# SANDOVAL	# ORIGINAL	MODELO	ANCHO	ESPESOR	L./C.	L./L.	BRÍO	BUJE L./C	BUJE L./L
32021	UCA0105	Caja F1, F2 Mod. 66-94 / Trasera	3"	0.499"	20 3/4"	20 3/4"	2 1/2"		
32021-1				0.499"	20 3/4"	20 3/4"			
32021-2				0.499"	20 3/4"	20 3/4"			
32021-3				0.499"	21"	21"			
32021-4				0.499"	16 1/4"	15 1/4"			
32021-5				0.499"	13 3/8"	13 3/8"			
32021-6				0.499"	11 1/8"	10 5/8"			
32021-7				0.499"	8 1/2"	8 1/2"			
32021-8				0.499"	6"	6"			

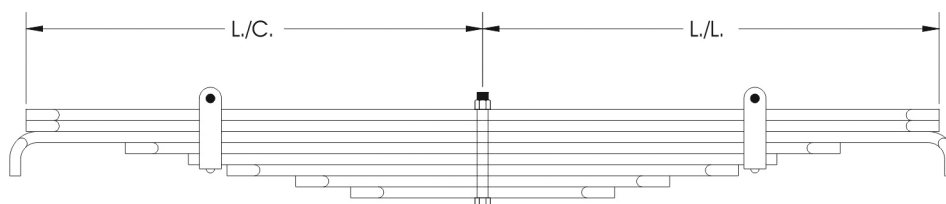

# SANDOVAL	# ORIGINAL	MODELO	ANCHO	ESPESOR	L./C.	L./L.	BRÍO	BUJE L./C	BUJE L./C
32021-B	UXA0252	Caja F1, F2 Mod. 66-94 / Trasera	3"	0.499"	20 3/4"	20 3/4"	2 1/2"		
32021-B1				0.499"	20 3/4"	20 3/4"			
32021-B2				0.499"	20 3/4"	20 3/4"			
32021-B3				0.499"	21"	21"			
32021-B4				0.499"	17 1/4"	17 1/4"			
32021-B5				0.499"	15 1/4"	16 1/4"			
32021-B6				0.499"	13 3/8"	13 3/8"			
32021-B7				0.499"	10 5/8"	11 1/8"			
32021-B8				0.499"	8 1/2"	8 1/2"			
32021-B9				0.499"	6"	6"			

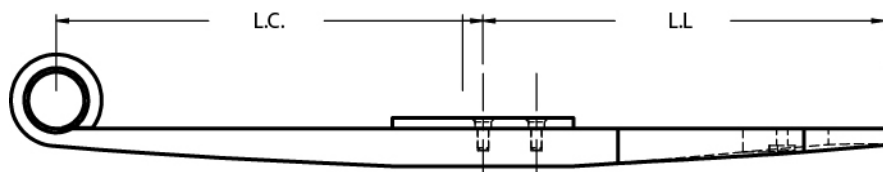

# SANDOVAL	# ORIGINAL	MODELO	ANCHO	ESPESOR	L./C.	L./L.	BRÍO	BUJE L./C	BUJE L./L
TRA-087	UCE000176-001	Izquierda	4.500"	0.499"	20"	20"	N/A	-	-
TRA-087-1			4.500"	0.499"	4 1/4"	4 1/4"			
TRA-087-2			4.500"	1.750"	20"	20"		2 5/8"	

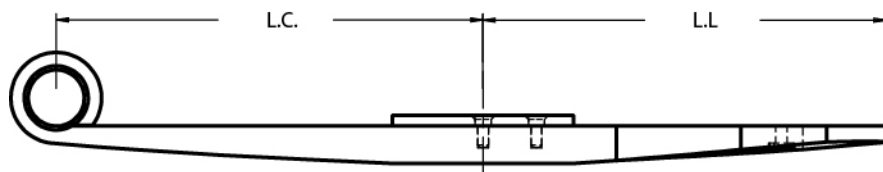

# SANDOVAL	# ORIGINAL	MODELO	ANCHO	ESPESOR	L./C.	L./L.	BRÍO	BUJE L./C	BUJE L./L
TRA-088	UCE000176-001	Derecha	4.500"	0.499"	20"	20"	N/A	-	-
TRA-088			4.500"	0.499"	4 1/4"	4 1/4"			
TRA-088			4.500"	1.750"	20"	20"		2 5/8"	

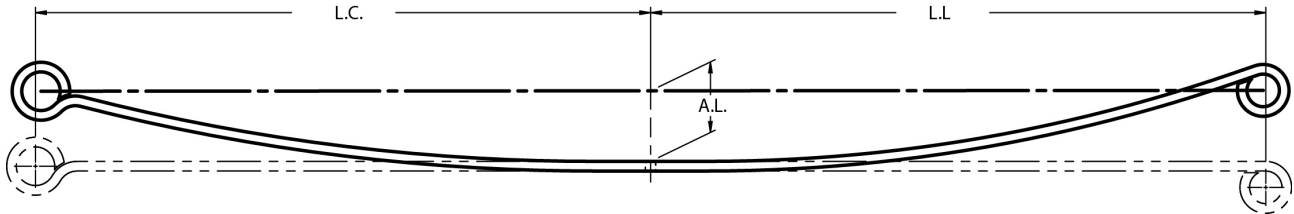

# SANDOVAL	# ORIGINAL	MODELO	ANCHO	ESPESOR	L./C.	L./L.	BRÍO	BUJE L./C	BUJE L./L
22-1801-1	23401106	Silverado 2017	3"	0.499"	32"	32"	3 21/32	RB-339	RB-340

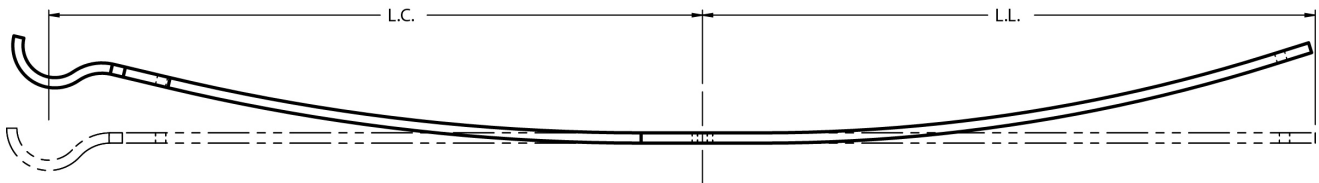

# SANDOVAL	# ORIGINAL	MODELO	ANCHO	ESPESOR	L./C.	L./L.	BRÍO	BUJE L./C	BUJE L./L
22-1801-2R	23401106	2da de refuerzo-Silverado 2017	3"	0.499"	32"	30"	-	-	-

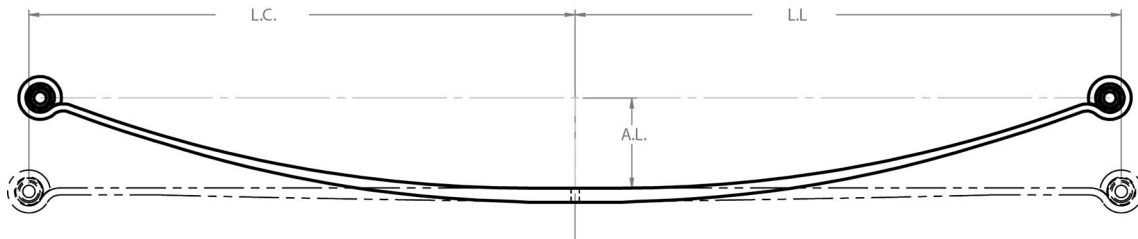

# SANDOVAL	# ORIGINAL	MODELO	ANCHO	ESPESOR	L./C.	L./L.	BRÍO	BUJE L./C	BUJE L./L
GM-0001-1	-	GMC T6500	3.500"	0.910"	35"	35"	5 3/4"	RB-190	RB-190

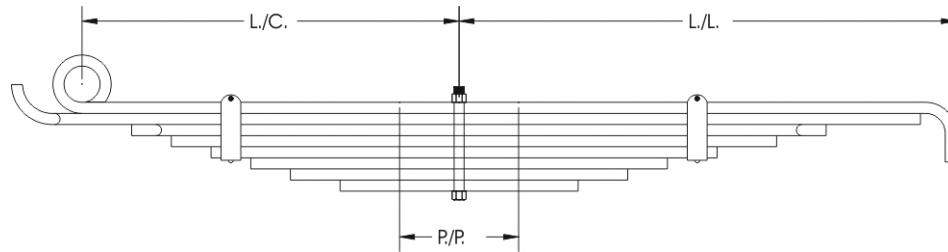

# SANDOVAL	# ORIGINAL	MODELO	ANCHO	ESPESOR	L./C.	L./L.	BRÍO	BUJE L./C	BUJE L./L
38019	BA47475	Susp. E-4 Mod. 87-89 / Trasera	3"	0.558"	19"	24 1/2"	3 3/4"		
38019-1				0.558"	19"	24 1/2"		RB-167	
38019-2				0.558"	23 1/2"	23 1/4"			
38019-3				0.558"	16 1/2"	18 1/2"			
38019-4				0.558"	14 1/2"	16"			
38019-5				0.558"	12 1/2"	13"			
38019-6				0.558"	10 1/2"	10 1/2"			
38019-7				0.558"	8 1/2"	8 1/2"			
38019-8				0.558"	6"	6"			

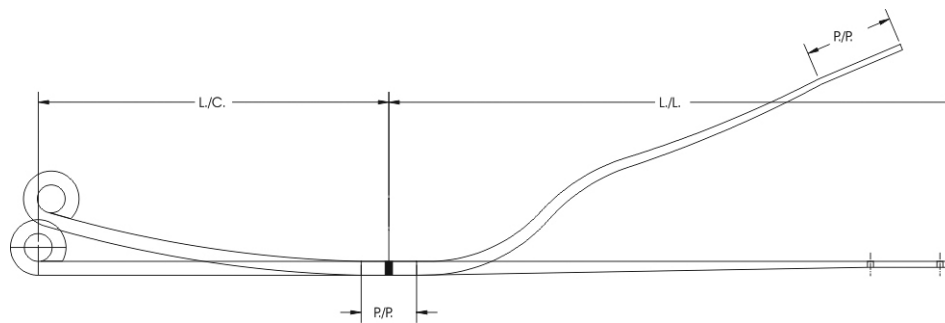

# SANDOVAL	# ORIGINAL	MODELO	ANCHO	ESPESOR	L./C.	L./L.	BRÍO	BUJE L./C	BUJE L./L
39725-MB	59930021	Century Columbia Mod. 2005 / Delantera	3"	0.999"	25 1/4"	40 3/4"	L.C. 4 1/2" L.L. 15 5/8"	RB-293	

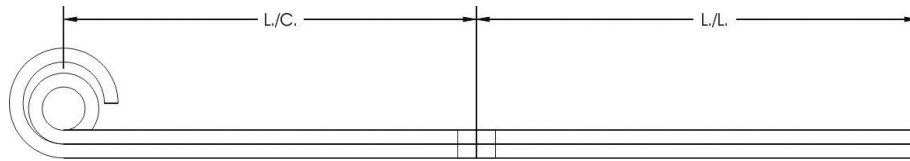

# SANDOVAL	# ORIGINAL	MODELO	ANCHO	ESPESOR	L./C.	L./L.	BRÍO	BUJE L./C	BUJE L./L
45117	BA25912	Tandem dos sus- pensiones / Trasera	4"	0.558"	17"	29"	Especial	TPK	
45217				0.558"	17"	29"	Especial		

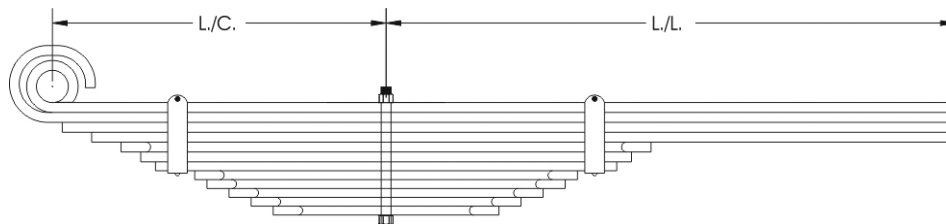

# SANDOVAL	# ORIGINAL	MODELO	ANCHO	ESPESOR	L./C.	L./L.	BRÍO	BUJE L./C	BUJE L./C
48017-G	BA45322	Susp. Hendrickson Revolvedora Mod. 02-12 / Trasera	4"	0.625"	17"	28 1/2"	Especial		
48017-G1				0.625"	17"	28 1/2"		BM-TPK	
48017-G2				0.625"	17"	28 1/2"			
48017-G3				0.625"	16 1/2"	28 1/2"			
48017-G4				0.625"	15 1/4"	17"			
48017-G5				0.625"	14"	14 1/2"			
48017-G6				0.625"	12 3/4"	12 3/4"			
48017-G7				0.625"	11 1/2"	11 1/2"			
48017-G8				0.625"	9 1/2"	9 1/2"			
48017-G9				0.625"	8 1/2"	8 1/2"			
48017-G10				0.625"	7 1/4"	7 1/4"			
48017-G11				0.625"	6"	6"			
48017-G12				0.625"	4 3/4"	4 3/4"			

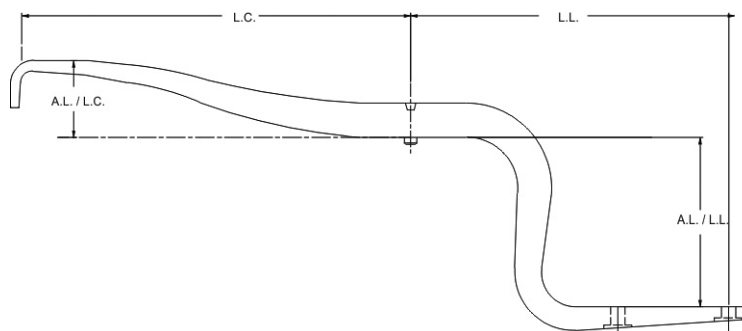

SUSPENSIÓN DE AIRE

# SANDOVAL	# ORIGINAL	MODELO	ANCHO	ESPESOR	L./C.	L./L.	BRÍO	BUJE L./C	BUJE L./C
50-363	48645-001	-	75 mm	60.3 mm	587mm	582 mm	LC 118mm LL 310mm		
50367Z	56871-001	Series Has -210 / Trasera	3"	1.875"	508 mm	459.5 mm	LC 115 mm L.L. 238 mm		
50387Z	56943-000	Series Has -210 / 400 Mod. 93-06 / Trasera	3"	1.875"	23 1/8"	19 15/16"	LC 114mm LL 251mm		
50389Z	56946-000	Series Has -230 / 402 / 460 Mod. 93-06 / Trasera	3"	2"	23 1/2"	30 1/4"	LC 110mm LL 251mm		

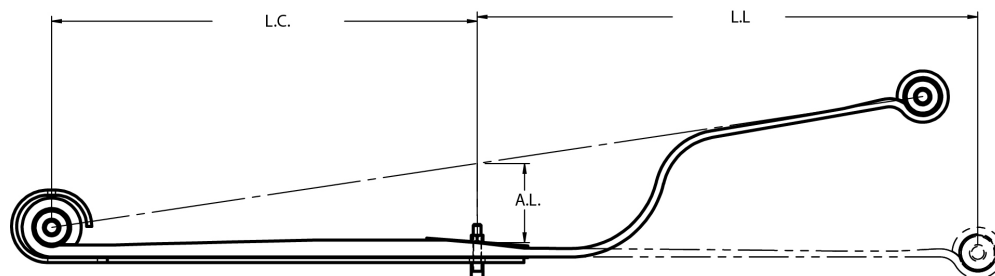

# SANDOVAL	# ORIGINAL	MODELO	ANCHO	ESPESOR	L./C.	L./L.	BRÍO	BUJE L./C	BUJE L./C
50-244	67420-000	Airtek	4"	1.085"	27 5/16"	32 1/8"			
50-244-1	-		4"	1.085"	27 5/16"	32 1/8"	5 1/16"	RB-302R	RB-302R
50-244-2	-		4"	0.323"	27 5/16"	30 5/16"	-		



# SANDOVAL	# ORIGINAL	MODELO	ANCHO	ESPESOR	Longitud	BRÍO	BUJE L./C	BUJE L./C
50389ZR	56946-000	Refuerzo para muelle zeta	3"	0.788"	23 3/4 " + 2 " + 2"	N/A		

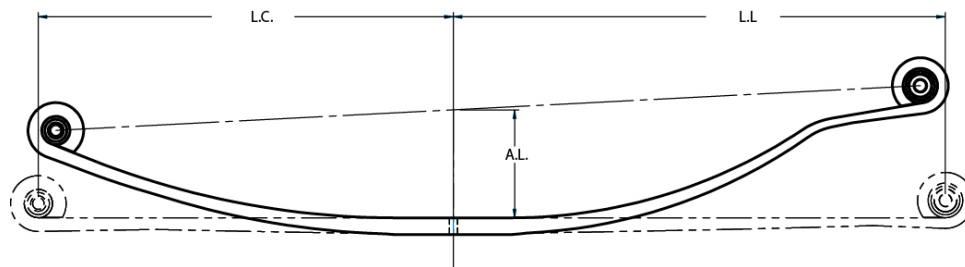

# SANDOVAL	# ORIGINAL	MODELO	ANCHO	ESPESOR	L./C.	L./L.	BRÍO	BUJE L./C	BUJE L./C
HE-0001	-	Airteck Delantera	3"	1.085"	27"	32"	7"	RB-233	RB-253

Hino

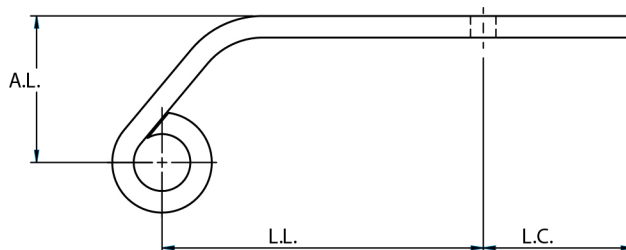

# SANDOVAL	# ORIGINAL	MODELO	ANCHO	ESPESOR	L./C.	L./L.	BRÍO	BUJE L./C	BUJE L./C
54-144-01	48150-2800A	Hino (Bracket)	3"	0.447"	3 1/8"	8 1/4"	3.034"	NA	NA

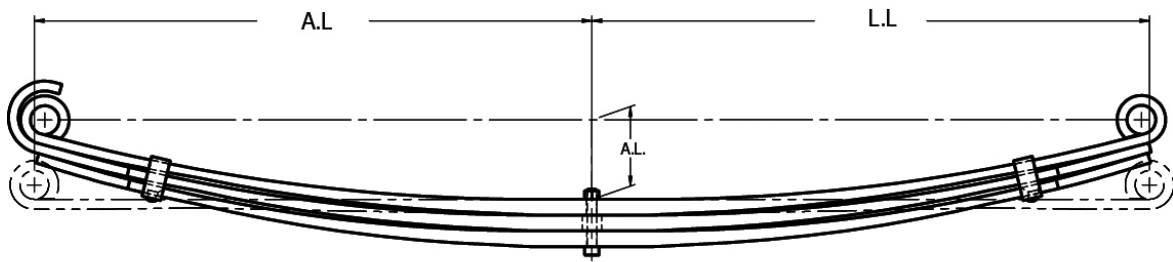

# SANDOVAL	# ORIGINAL	MODELO	ANCHO	ESPESOR	L./C.	L./L.	BRÍO	BUJE L./C	BUJE L./L
802129-HI	481502800	Mod. 145/338 Mod. 05-11 / Delantera	80 mm	21 mm	29"	29"	4 1/8"		
802129-HI1				21 mm	29"	29"		BB-M8383	BB-M8383
802129-HI2				21 mm	29"	29 1/4"			
802129-HI3				21 mm	29 1/4"	29 1/4"			

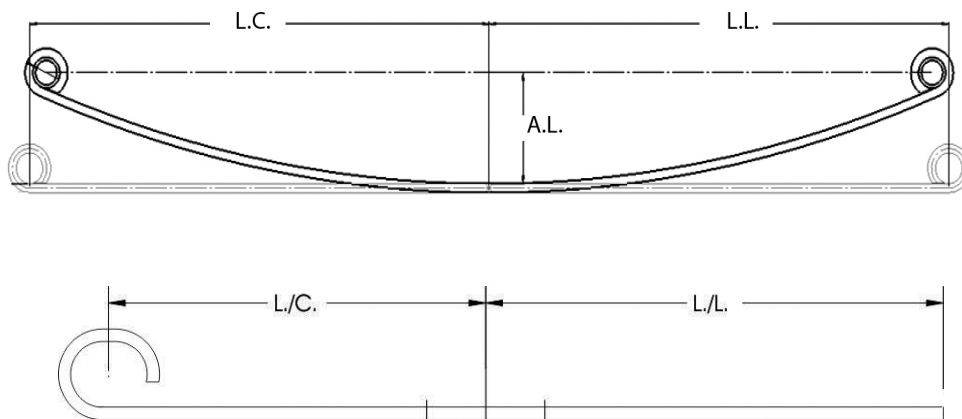

# SANDOVAL	# ORIGINAL	MODELO	ANCHO	ESPESOR	L./C.	L./L.	BRÍO	BUJE L./C	BUJE L./C
701125-HI	300C011	Hino 300 Mod. 2011 / Trasera	70 mm	11 mm	25 9/16"	25 9/16"	5 3/8"		
701125-HI1				11 mm	25 9/16"	25 9/16"		1.50"	1.50"
701125-HI2				11 mm	650 mm	660 mm			

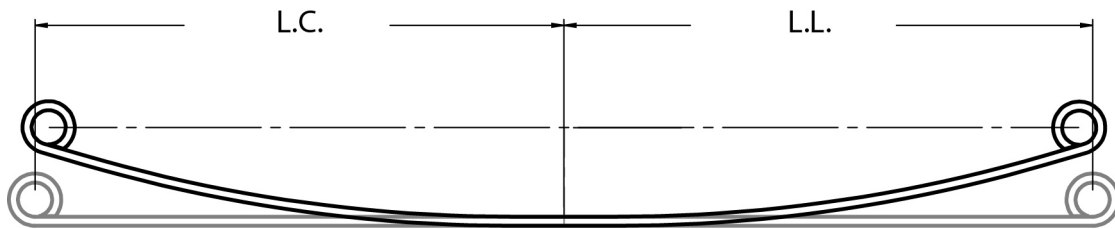

# SANDOVAL	# ORIGINAL	MODELO	ANCHO	ESPESOR	L./C.	L./L.	BRÍO	BUJE L./C	BUJE L./C
HI-0001-1	-	Hino	90 mm	12 mm	27 1/2"	27 1/2"	4 5/8"	45 mm	45 mm

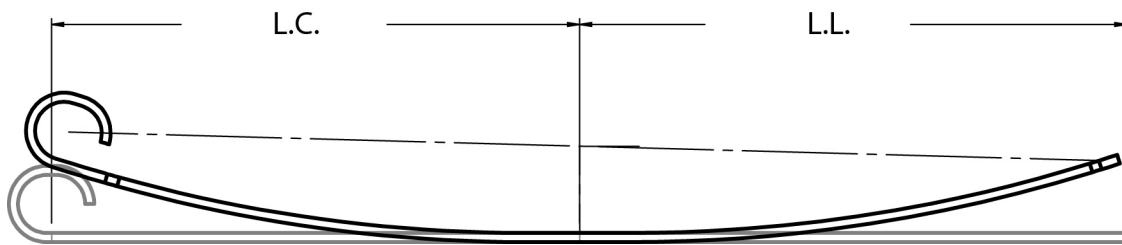

# SANDOVAL	# ORIGINAL	MODELO	ANCHO	ESPESOR	L./C.	L./L.	BRÍO	BUJE L./C	BUJE L./C
HI-0001-2R	-	2da Refuerzo Hino	90 mm	12 mm	27 1/2"	28 1/2"	4 5/8"	-	45 mm

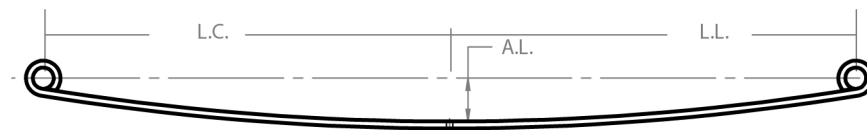

# SANDOVAL	# ORIGINAL	MODELO	ANCHO	ESPESOR	L./C.	L./L.	BRÍO	BUJE L./C	BUJE L./C
HI-0002-1	48110-37Y20	Trasera	2 3/4"	0.433"	25 5/8"	25 5/8"	2 11/16"	-	-

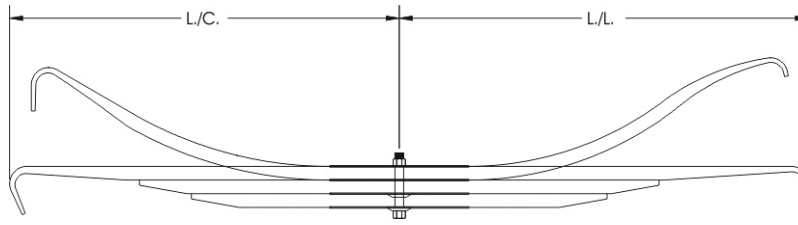

# SANDOVAL	# ORIGINAL	MODELO	ANCHO	ESPESOR	L./C.	L./L.	BRÍO	BUJE L./C	BUJE L./C
TRA2726	35400	Caja Americana Mod. 86-98 / Trasera	3"	0.788"	23 3/4"	22 3/16"	6"		
TRA2726-1				0.788"	23 3/4"	22 3/16"			
TRA2726-2				0.788"	14 1/2"	14 1/2"			
TRA2726-3				0.788"	9 1/4"	9 1/4"			

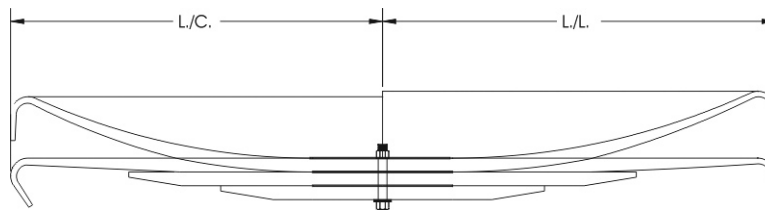

# SANDOVAL	# ORIGINAL	MODELO	ANCHO	ESPESOR	L./C.	L./L.	BRÍO	BUJE L./C	BUJE L./C
TRA2727	35500	Caja Americana Mod. 86-98 / Trasera	3"	0.788"	23 "	21 5/8"	4 1/2"		
TRA2727-1				0.788"	23"	21 5/8"			
TRA2727-2				0.788"	14 1/2"	14 1/2"			
TRA2727-3				0.788"	9 1/4"	9 1/4"			

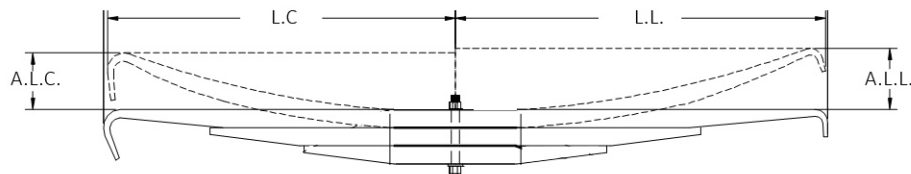

# SANDOVAL	# ORIGINAL	MODELO	ANCHO	ESPESOR	L./C.	L./L.	BRÍO	BUJE L./C	BUJE L./C
TRA2741	36501	Caja seca Mod. 94-98 / Trasera	3"	0.938"	21 1/2"	22 3/4"	LC 3 1/8" LL 3 3/8"		
TRA2741-1				0.938"	21 1/2"	22 3/4"			
TRA2741-2				0.938"	15"	145"			
TRA2741-3				0.938"	21 1/2"	22 3/4"			

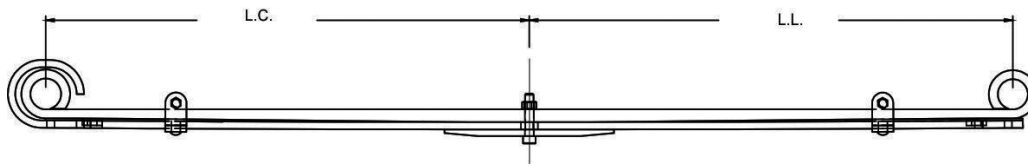

# SANDOVAL	# ORIGINAL	MODELO	ANCHO	ESPESOR	L./C.	L./L.	BRÍO	BUJE L./C	BUJE L./L
HY-0001	55-100-60	Hyundai Mod. 2014 / Trasera	80 mm	19 mm	725 mm	725 mm	Recto		
PAD			76.2 mm	7 mm	127 mm	127 mm			
HY-0001-1			80 mm	19 mm	725 mm	725 mm		RB-218	RB-218
HY-0001-2			80 mm	11 mm	725 mm	740 mm			

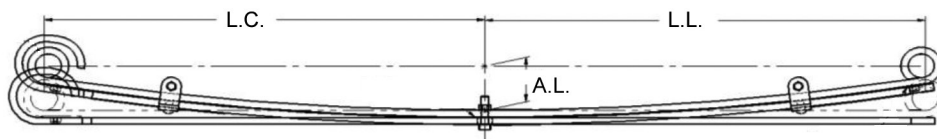

# SANDOVAL	# ORIGINAL	MODELO	ANCHO	ESPESOR	L./C.	L./L.	BRÍO	BUJE L./C	BUJE L./L
HY-0002	54100-6J200	Hyundai Mod.2014 / Delantera	2.756"	0.472"	27 7/8"	28 1/2"	3 1/8"		
HHY-0002-1				0.472"	27 7/8"	28 1/2"		RB-246R	RB-246R
HHY-0002-2				0.472"	27 7/8"	27 7/8"			

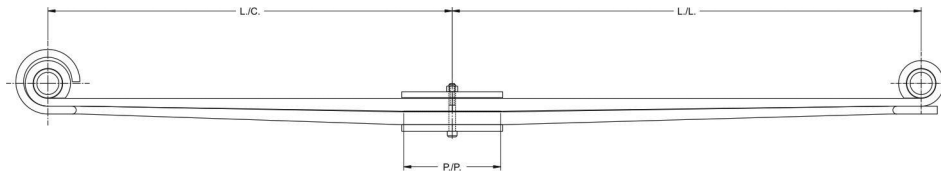

# SANDOVAL	# ORIGINAL	MODELO	ANCHO	ESPESOR	L./C.	L./L.	BRÍO	BUJE L./C	BUJE L./C
39025-IN	3533196C91	Serie 4200 Mod. 02-06 / Delantera	3"	0.788"	25"	29"	3 9/16"		
PAD				0.360"	3 1/8"	3 1/8"			
39025-IN1				0.788"	25"	29"		RB-270	RB-270
39025-IN2				0.788"	25"	30"			
PAD				0.401"	3 1/8"	3 1/8"			

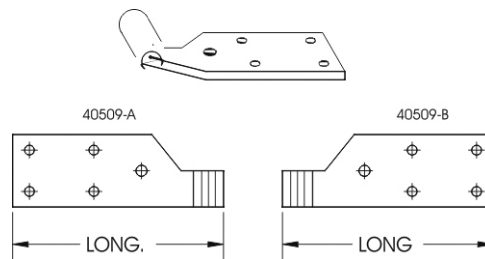

# SANDOVAL	# ORIGINAL	APLICACIÓN	MODELO	AÑO	ANCHO	ESPESOR	L./C.	L./L.	BRÍO
40509	-	Trasera	Bracket	89-00	3 1/2"	0.401"	-	-	N/A
40509-A	579637C2		Bracket Izquierdo			0.401"	3 1/16"	6 1/4"	N/A
40509-B	579638C2		Bracket Derecho			0.401"	25"	29"	N/A

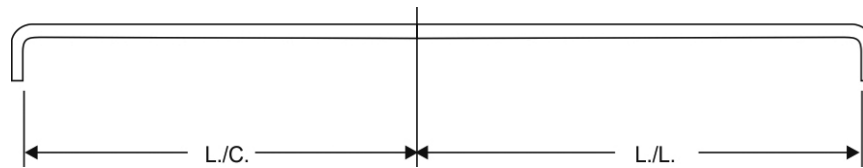

# SANDOVAL	# ORIGINAL	MODELO	ANCHO	ESPESOR	L./C.	L./L.	BRÍO	BUJE L./C	BUJE L./L
41723-G	2995910C91M	Dina S9400 Mod. 94-98 / Trasera	3 1/2"	0.499"	23"	25"	4"		

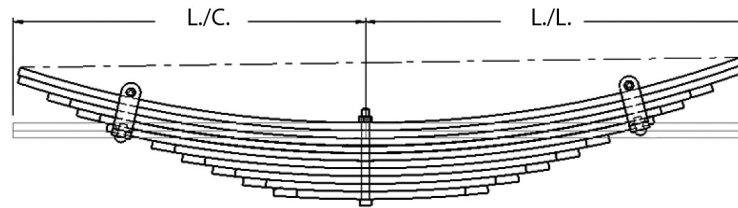

# SANDOVAL	# ORIGINAL	MODELO	ANCHO	ESPESOR	L./C.	L./L.	BRÍO	BUJE L./C	BUJE L./C
41723-N	2995910C91	Dina S9400 Mod. 94-98 / Trasera	3 1/2"	0.499"	23"	25"	4"		
41723-N1				0.499"	23"	25"			
41723-N2				0.499"	23"	25"			
41723-N3				0.499"	21"	23"			
41723-N4				0.499"	19"	21"			
41723-N5				0.499"	17"	19"			
41723-N6				0.499"	14"	16"			
41723-N7				0.499"	12"	14"			
41723-N8				0.499"	10"	12"			
41723-N9				0.499"	8"	10"			
41723-N10				0.499"	6"	8"			

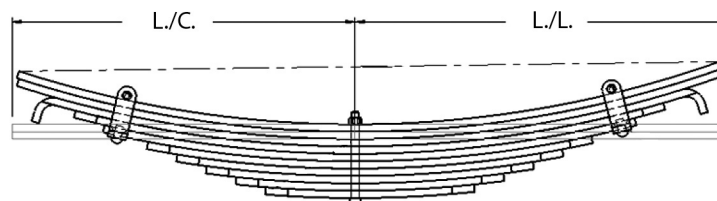

# SANDOVAL	# ORIGINAL	MODELO	ANCHO	ESPESOR	L./C.	L./L.	BRÍO	BUJE L./C	BUJE L./L
41723-NE	2995910C91	Adaptacion Dina S9400 Mod. 94-98 /Trasera	3 1/2"	0.499"	23"	25"	4"		
41723-NE1				0.499"	23"	25"			
41723-NE2				0.499"	23"	25"			
41723-NE3				0.499"	21"	23"			
41723-NE4				0.499"	19"	21"			
41723-NE5				0.499"	17"	19"			
41723-NE6				0.499"	14"	16"			
41723-NE7				0.499"	12"	14"			
41723-NE8				0.499"	10"	12"			
41723-NE9				0.499"	8"	10"			
41723-NE10				0.499"	6"	8"			

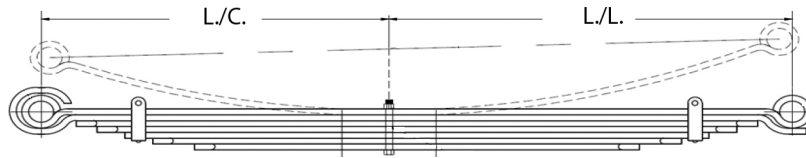

# SANDOVAL	# ORIGINAL	MODELO	ANCHO	ESPEJOR	L./C.	L./L.	BRÍO	BUJE L./C	BUJE L./L
42025-IN	533563C91	Adaptacion Especial Mod. 02-05 / Delantera	4"	0.499"	25"	29"	5 1/8"		
42025-IN1				0.499"	25"	29"		RB-253	RB-253
42025-IN2				0.499"	25"	29"			
42025-IN3				0.499"	22 1/2"	26 1/2"			
42025-IN4				0.499"	21"	25"			
42025-IN5				0.499"	19"	23"			
42025-IN6				0.499"	17"	21"			
42025-IN7				0.499"	14"	18"			

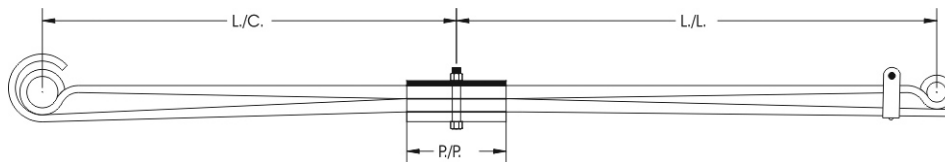

# SANDOVAL	# ORIGINAL	MODELO	ANCHO	ESPEJOR	L./C.	L./L.	BRÍO	BUJE L./C	BUJE L./L
49025-I	3533197C91	Navistar 4200 VT 365 Mod. 2003 / Delantera	4"	0.788"	25"	29"	5 1/2"		
PAD				0.323"	3"	3"			
49025-I1				0.788"	25"	29"		TB-26 c/caja	TB-26 c/caja
49025-I2				0.788"	25"	30"			
PAD				0.323"	3"	3"			

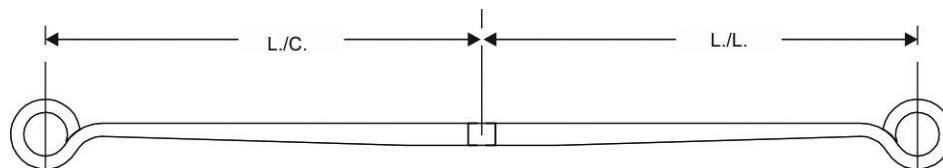

# SANDOVAL	# ORIGINAL	MODELO	ANCHO	ESPEJOR	L./C.	L./L.	BRÍO	BUJE L./C	BUJE L./L
49125-IT	3556301C91	Serie 8000 Mod. 02-06 / Delantera	4"	0.788"	25"	29"	5 1/2"	RB-253	RB-253

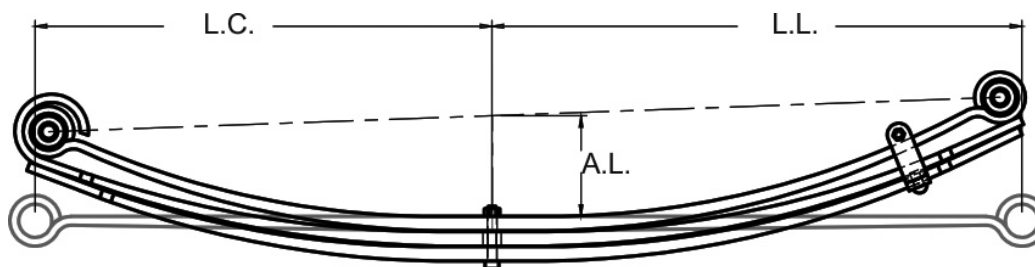

# SANDOVAL	# ORIGINAL	MODELO	ANCHO	ESPEJOR	L./C.	L./L.	BRÍO	BUJE L./C	BUJE L./L
49025M-IT	-	Serie 8000 Mod. 2003 / Delantera	4"	0.788"	25"	29"	5 1/2"		
49025M-IT1				0.788"	25"	29"		RB-253	RB-253
49025M-IT2				0.788"	25"	30"			
49025M-IT3				0.788"	26"	30"			

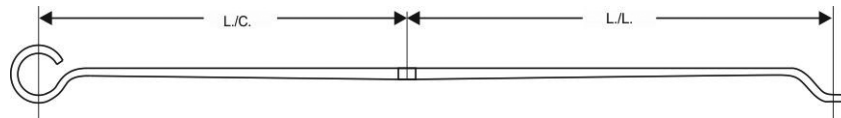

# SANDOVAL	# ORIGINAL	MODELO	ANCHO	ESPESOR	L./C.	L./L.	BRÍO	BUJE L./C.	BUJE L./L.
49225-I2	3556301C91	Serie 8000 Mod. 02-06 / Delantera	4"	0.788"	25"	29"	5 1/2"		

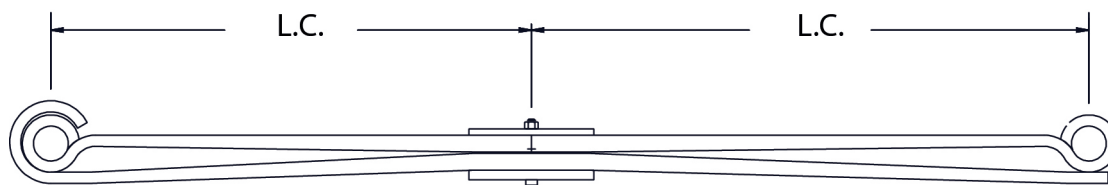

# SANDOVAL	# ORIGINAL	APLICACIÓN	MODELO	AÑO	ANCHO	ESPESOR	L./C.	L./L.	BRÍO
50025-IT	-	Delantera		007-2008	4"	0.999"	25"	29"	4 3/4"
50025-IT1					4"	0.999"	25"	29"	
50025-IT2					4"	0.999"	25"	30"	

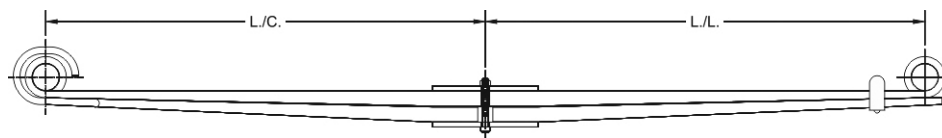

# SANDOVAL	# ORIGINAL	MODELO	ANCHO	ESPEJOR	L/C.	L/L.	BRÍO	BUJE L/C	BUJE L/L
50029-IN	3527263C91	Serie 9000 Mod. 96-06 / Delantera	4"	0.999"	29"	29"	3 7/8"		
PAD				0.323"	3 1/2"	3 1/2"			
50029-IN1				0.999"	29"	29"		RB-253	RB-253
50029-IN2				0.999"	29"	29"			
PAD				0.323"	3 1/2"	3 1/2"			

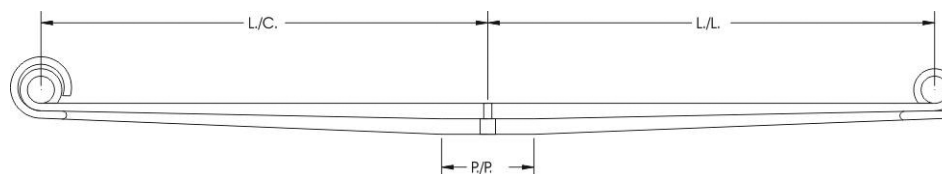

# SANDOVAL	# ORIGINAL	MODELO	ANCHO	ESPEJOR	L/C.	L/L.	BRÍO	BUJE L/C	BUJE L/L
50029-IT	1690075C91	Serie 9700 Mod. 96-99 / Delantera	4"	0.999"	29"	29"	4"		
50029-IT1				0.999"	29"	29"		TB-26 c/caja	TB-26 c/caja
50029-IT2				0.999"	29"	30"			

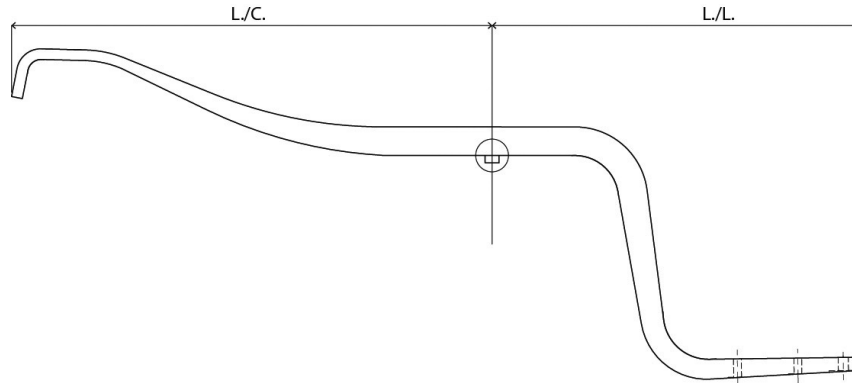

# SANDOVAL	# ORIGINAL	MODELO	ANCHO	ESPESOR	L./C.	L./L.	BRÍO	BUJE L./C	BUJE L./C
55-067	501566C92	Navistar , Series 2000, 4000, 700, tractor Mod.89-00 / Trasera	3 1/2"	1 1/2"	18 15/16"	25 1/8"	LC. 2 5/8" LL. 10 9/16"		
55-1133Z	1684471C91	Navistar Serie 4000-7000 Mod. 89-01 / Trasera	3 1/2"	1 1/2"	20 5/16"	25 1/8"	LC. 4" LL. 12"		

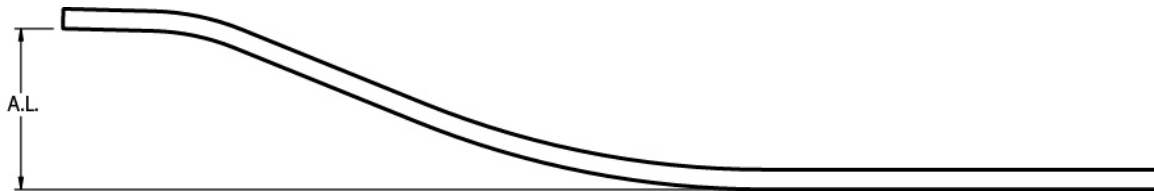

# SANDOVAL	# ORIGINAL	MODELO	ANCHO	ESPESOR	L. Total	BRÍO	BUJE L./C	BUJE L./L
55067ZR	-	Hoja de Refuerzo Suspension de Aire Navistar	4"	0.788"	28 1/2"	4 1/8"	N/A	N/A

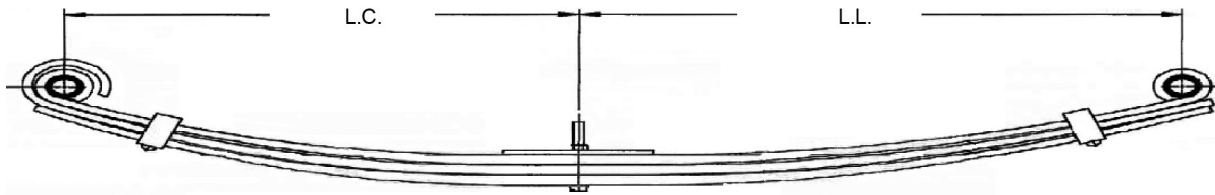

# SANDOVAL	# ORIGINAL	MODELO	ANCHO	ESPESOR	L./C.	L./L.	BRÍO	BUJE L./C	BUJE L./L
55-900	507206C91	Serie 9000 Mod. 1988- 1999 / Delantera	4"	0.788"	25"	29"	5 1/8"		
PAD				0.323"	3 1/2"	3 1/2"			
55-900-1				0.788"	25"	29"		TB-26	TB-26
55-900-2				0.788"	25"	30 1/4"			
55-900-3				0.788"	26 1/4"	30 1/4"			

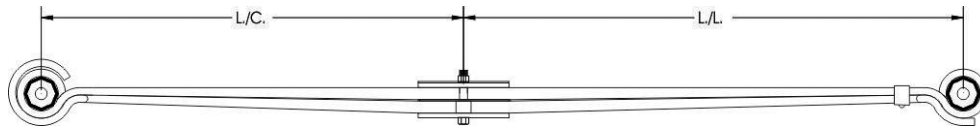

# SANDOVAL	# ORIGINAL	MODELO	ANCHO	ESPESOR	L./C.	L./L.	BRÍO	BUJE L./C	BUJE L./L
55-1180	1680499C91	Navistar Series 7000 Mod. 02-06 / Delantera	3"	0.702"	25"	25"	5"		
PAD				0.625"	3"	3"			
55-1180-1				0.702"	25"	25"		RB-75	RB-75
55-1180-2				0.702"	25"	26 1/4"			
PAD				0.401"	3"	3"			

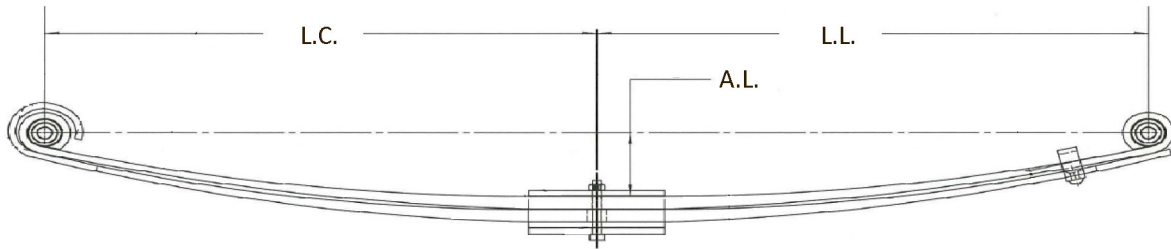

# SANDOVAL	# ORIGINAL	MODELO	ANCHO	ESPESOR	L./C.	L./L.	BRÍO	BUJE L./C	BUJE L./L
55-1216	3527262C91	-	4"	0.812"	29"	29"	4.12"		
PAD			4"	0.323"	3 1/2"	3 1/2"			
55-1216-1			4"	0.812"	29"	29"		RB-253	RB-253
55-1216-2			4"	0.812"	29"	30"			
PAD			4"	0.401"	3 1/2"	3 1/2"			
PAD			4"	0.401"	3 1/2"	3 1/2"			

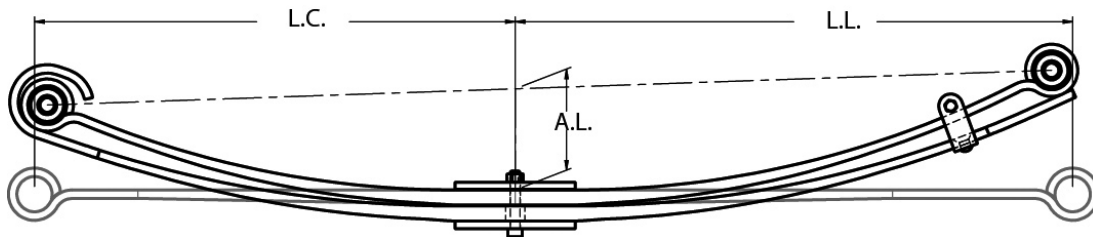

# SANDOVAL	# ORIGINAL	MODELO	ANCHO	ESPESOR	L./C.	L./L.	BRÍO	BUJE L./C	BUJE L./L
55-1238	3533196C91	Navistar Series 300,4000 Mod.05- 06 / Delantera	3"	0.788"	25"	29"	3 1/4"		
PAD				0.360"	3 1/8"	3 1/8"			
55-1238-1				0.788"	25"	29"		RB-270	RB-270
55-1238-2				0.788"	25"	30"			
PAD				0.401"	3 1/8"	3 1/8"			

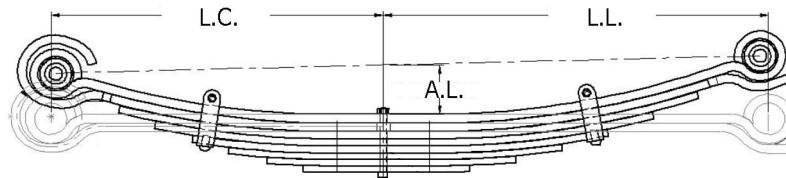

# SANDOVAL	# ORIGINAL	MODELO	ANCHO	ESPESOR	L./C.	L./L.	BRÍO	BUJE L./C	BUJE L./L
55-1248	3540085C91	Navistar	4"	0.702"	25"	29"	3 13/16"		
55-1248-1				0.702"	25"	29"		RB-269	RB-269
55-1248-2				0.662"	25"	29"			
55-1248-3				0.558"	20"	24"			
55-1248-4				0.558"	17 1/4"	20 1/2"			
55-1248-5				0.558"	14 3/8"	17"			
55-1248-6				0.499"	11 5/8"	13 1/2"			
55-1248-7				0.499"	8 3/4"	10"			
55-1248-8				0.499"	6 1/2"	12 1/2"			

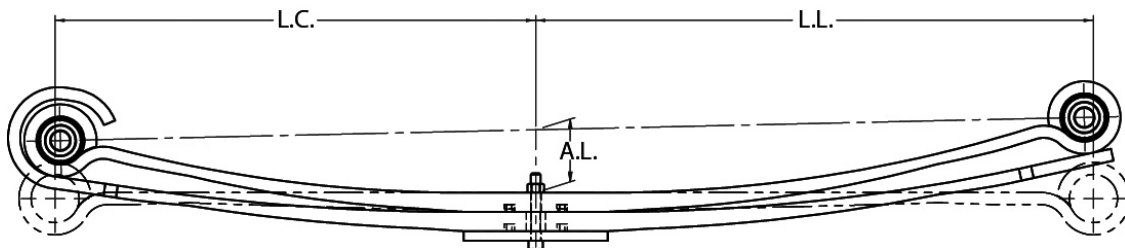

# SANDOVAL	# ORIGINAL	MODELO	ANCHO	ESPESOR	L./C.	L./L.	BRÍO	BUJE L./C	BUJE L./L
55-1256	3540219C91	Navistar Series 7000 Mod.02-06 / Delantera	4"	0.999"	25"	29"	3 1/4"		
55-1256-1				0.999"	25"	29"		RB-269	RB-269
55-1256-2				0.999"	25"	30 1/4"			

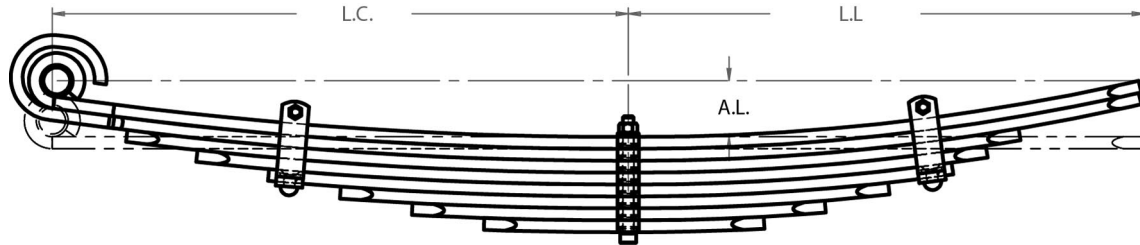

# SANDOVAL	# ORIGINAL	MODELO	ANCHO	ESPEJOR	L./C.	L./L.	BRÍO	BUJE L./C	BUJE L./L
55-1516	3852719C92	Navistar 8 Lf	4"	0.558"	27"	24 3/16"	2 5/8"		
55-1516-1				0.558"	27"	24 3/16"		BM-RNK	N/A
55-1516-2				0.558"	27"	24 3/16"			
55-1516-3				0.558"	23 9/16"	18 7/16"			
55-1516-4				0.558"	20 1/4"	16 7/8"			
55-1516-5				0.558"	16 7/8"	15 1/4"			
55-1516-6				0.558"	13 1/2"	12 1/4"			
55-1516-7				0.558"	10 1/8"	9 1/4"			
55-1516-8				0.558"	6 3/4"	6 3/8"			

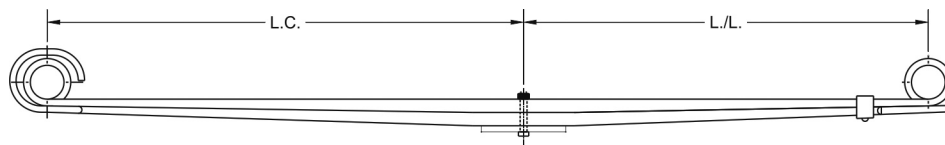

# SANDOVAL	# ORIGINAL	MODELO	ANCHO	ESPEJOR	L./C.	L./L.	BRÍO	BUJE L./C	BUJE L./L
IT-0001	-	Chato Americano	4"	0.662"	25"	27 1/2"	3 1/4"		
IT-0001-1				0.662"	25"	27 1/2"		TB-26	TB-26
IT-0001-2				0.662"	25"	28 1/2"			

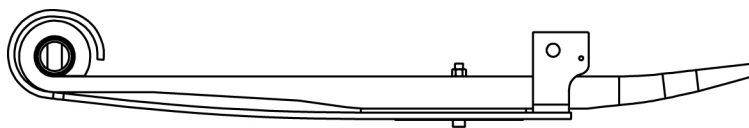

# SANDOVAL	# ORIGINAL	MODELO	ANCHO	ESPEJOR	L./C.	L./L.	BRÍO	BUJE L./C	BUJE L./L
IT-0003	-	Prosta 2013	3"	2.000"	25 1/4"	19 1/2"	-		
IT-0003-1			3"	2.000"	25 1/4"	19 1/2"		RB-268	-
IT-0003-2			3"	0.401"	25 1/2"	7"			

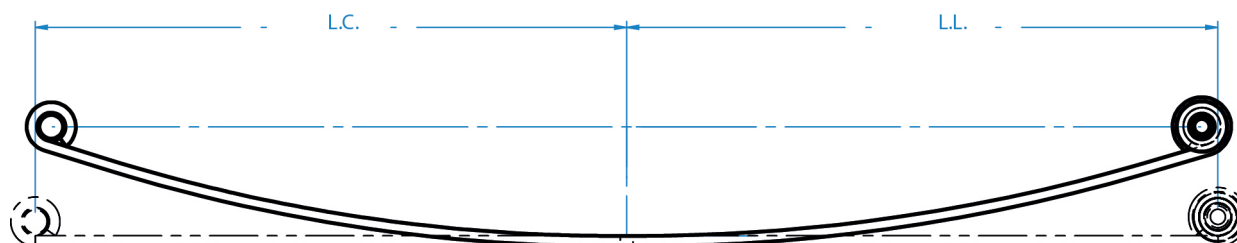

# SANDOVAL	# ORIGINAL	MODELO	ANCHO	ESPEJOR	L./C.	L./L.	BRÍO	BUJE L./C	BUJE L./L
IT-0004-1	-	International City Star JAC	70mm	11 mm	625	625	115 mm		BM-M73025

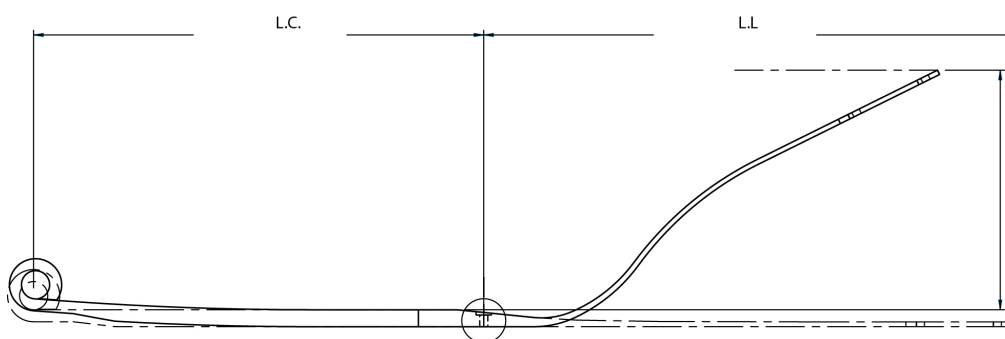

# SANDOVAL	# ORIGINAL	MODELO	ANCHO	ESPEJOR	L./C.	L./L.	BRÍO	BUJE L./C	BUJE L./L
IT-0005	66420	International 9400 prostar, Mod. 2012	100mm	28 mm	743	879	396 mm		-

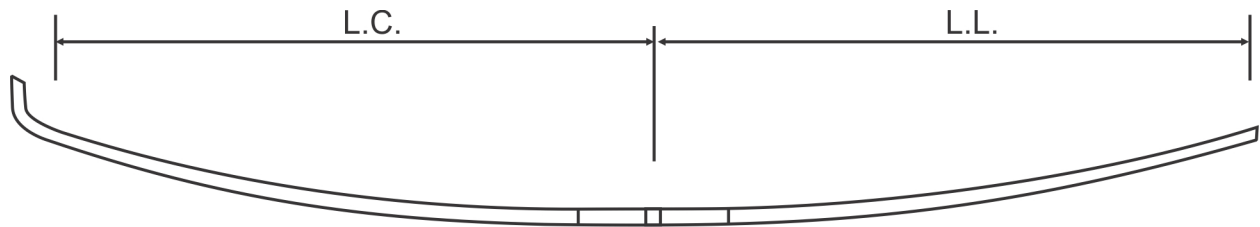

# SANDOVAL	# ORIGINAL	MODELO	ANCHO	ESPESOR	L./C.	L./L.	BRÍO	BUJE L./C	BUJE L./L
56-297-2	8980799040	Elf 600 Mod. 2012	70 mm	12 mm	654 mm	650 mm	97 mm	-	-

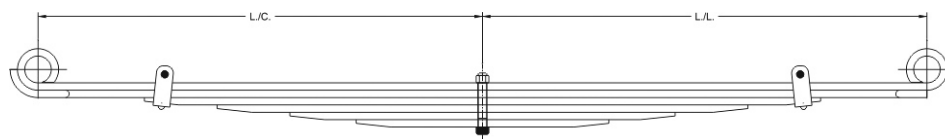

# SANDOVAL	# ORIGINAL	MODELO	ANCHO	ESPESOR	L./C.	L./L.	BRÍO	BUJE L./C	BUJE L./L
24726-IZ	9501916421	W35-45 Mod. 2006 / Trasera	70 mm	11 mm	26 3/8"	26 3/8"	4"		
24726-IZ1				11 mm	26 3/8"	26 3/8"		40 mm	40 mm
24726-IZ2				11 mm	26 3/8"	26 3/8"			
24726-IZ3				11 mm	20 1/16"	20 1/16"			
24726-IZ4				11 mm	15 3/4"	15 3/4"			
24726-IZ5				11 mm	11 7/16"	11 7/16"			
24726-IZ6				11 mm	7 1/2"	7 1/2"			

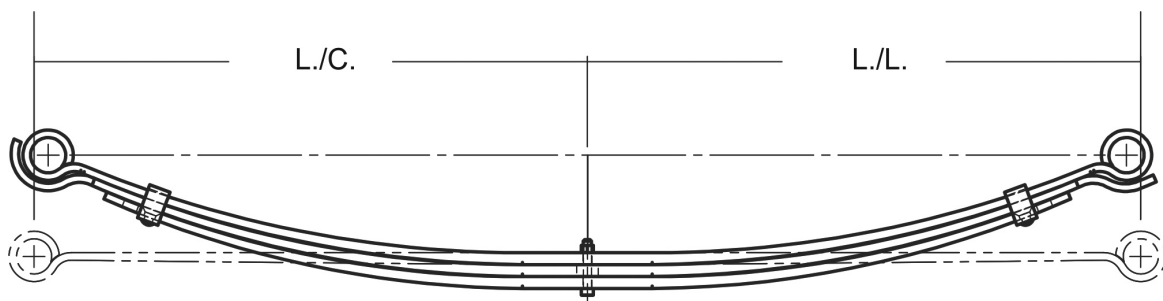

# SANDOVAL	# ORIGINAL	MODELO	ANCHO	ESPESOR	L./C.	L./L.	BRÍO	BUJE L./C	BUJE L./C
28925-IZ	-	ELF-450-400 Mod. 08-10 / Delantero	70 mm	15 mm	25 19/32"	25 19/32"	4 1/2"		
28925-IZ1				15 mm	25 19/32"	25 19/32"		RB-207MR	RB-207MR
28925-IZ2				15 mm	25 19/32"	25 19/32"			
28925-IZ3				15 mm	22 4/5"	22 4/5"			

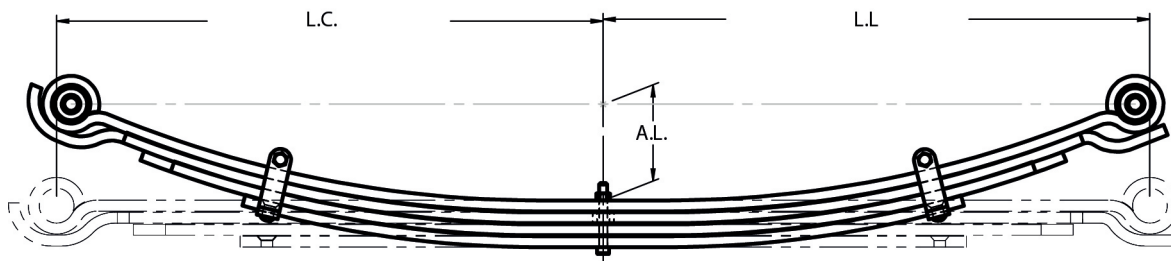

# SANDOVAL	# ORIGINAL	MODELO	ANCHO	ESPESOR	L./C.	L./L.	BRÍO	BUJE L./C	BUJE L./C
28925-IZM	-	ELF-460 / ELF 400 DELANTERA 2006 4 CIL. DIESEL. MODIFICADA	70 mm	13 mm	25 19/32"	25 19/32"	4 1/2"		
28925-IZM1			70 mm	13 mm	25 19/32"	25 19/32"		RB-207	RB-207
28925-IZM2			70 mm	13 mm	25 19/32"	25 19/32"			
28925-IZM3			70 mm	13 mm	22"	22"			
28925-IZM4			70 mm	13 mm	17"	17"			

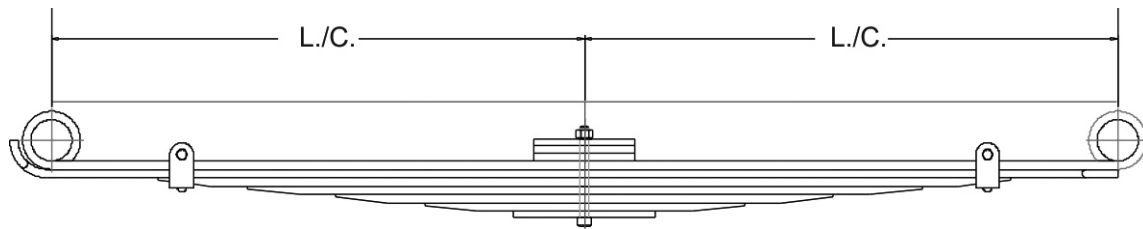

# SANDOVAL	# ORIGINAL	MODELO	ANCHO	ESPESOR	L./C.	L./L.	BRÍO	BUJE L./C	BUJE L./L
21622-IZ	9501916421	ELF 300 4 Cil Diesel Mod. 2008 / Delantero	60 mm	9 mm	22 1/2"	22 1/2"	2 1/2"	44mm	44mm
21622-IZ1				9 mm	22 1/2"	22 1/2"			
21622-IZ2				9 mm	22 1/2"	22 1/2"			
21622-IZ2RD				9 mm	22 3/4"	22 3/4"			
21622-IZ3				9 mm	18"	18"			
21622-IZ4				9 mm	14 1/4"	14 1/4"			
21622-IZ5				9 mm	10 1/2"	10 1/2"			
21622-IZ6				9 mm	6 3/4"	6 3/4"			
21622-IZ7				7 mm	3.00"	3.00"			
PAD				8 mm	2 1/8"	2 1/8"			
PAD				8 mm	2 1/8"	2 1/8"			
PAD				8 mm	2 1/8"	2 1/8"			

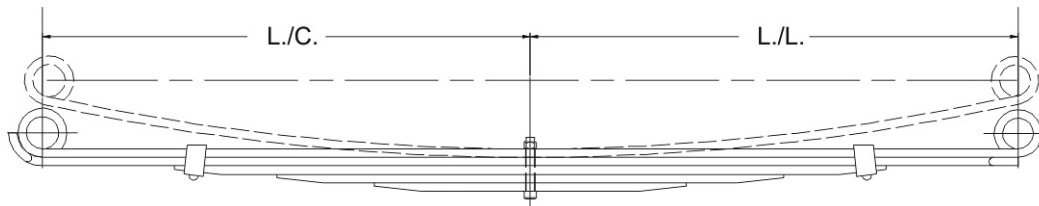

# SANDOVAL	# ORIGINAL	MODELO	ANCHO	ESPESOR	L./C.	L./L.	BRÍO	BUJE L./C	BUJE L./L
24725-IZ	9501916421	ELF 300 4 CIL Diesel Mod. 2008 / Trasera	70 mm	11 mm	25"	25"	3 1/2"		
24725-IZ1				11 mm	25"	25"		42 mm	40 mm
24725-IZ2				11 mm	25 1/8"	25 1/2"			
24725-IZ3				11 mm	18 1/4"	18 1/4"			
24725-IZ4				11 mm	13"	13"			
24725-IZ5				11 mm	8"	8"			



# SANDOVAL	# ORIGINAL	MODELO	ANCHO	ESPESOR	L./C.	L./L.	BRÍO	BUJE L./C	BUJE L./L
27827-IZ1			70 mm	10 mm	27"	26 5/8"	5 1/2"	1 5/8"	1 5/8"
27827-IZ2			70 mm	10 mm	27"	26 5/8"	5 1/2"		

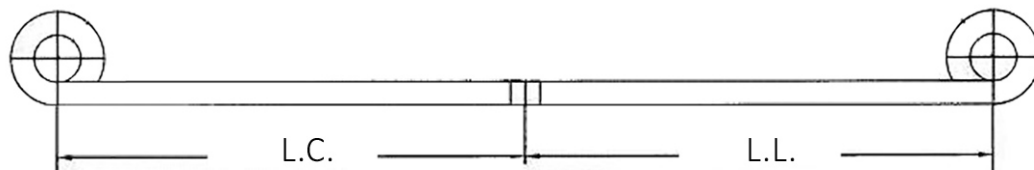

# SANDOVAL	# ORIGINAL	MODELO	ANCHO	ESPEJOR	L./C.	L./L.	BRÍO	BUJE L./C	BUJE L./L
17123	-	Mod. 66-94 / Trasera	1 3/4"	0.360"	23"	23"	4 3/4"	7/8"	7/8"

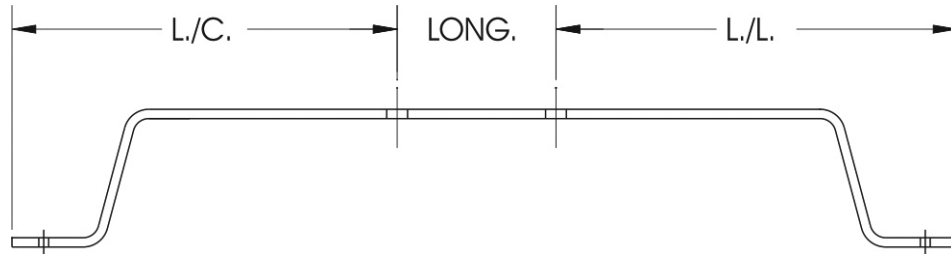

# SANDOVAL	# ORIGINAL	MODELO	ANCHO	ESPESOR	L./C.	CENTRO	L./L.	BRÍO	BUJE L./C	BUJE L./L
18635-CV	1690075C91	Serie 9700 Mod.96-99 / Delantera	2"	0.291"	11 1/8"	5"	11 5/8"	4"	N/A	N/A

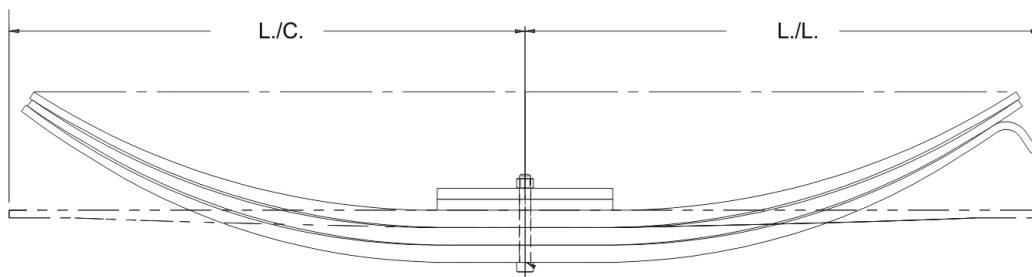

# SANDOVAL	# ORIGINAL	MODELO	ANCHO	ESPESOR	L./C.	L./L.	BRÍO	BUJE L./C	BUJE L./L
39023-K	2128602	Tandem Susp.Reyco Mod. 00-01 / Trasera	3"	0.788"	23 1/2"	23 1/2"	5 3/8"		
39023-K1				0.788"	23 1/2"	23 1/2"			
39023-K2				0.788"	23 3/4"	23 3/4"			
39023-K3				0.788"	24 1/4"	23 1/4"			

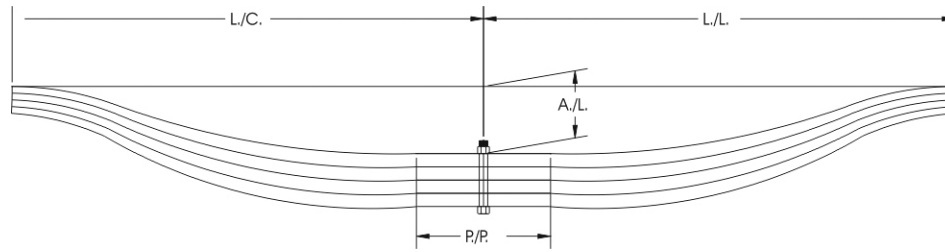

# SANDOVAL	# ORIGINAL	MODELO	ANCHO	ESPESOR	L/C.	L./L.	BRÍO	BUJE L/C	BUJE L./L
39028-K	1996701	Susp.Reyco T-300 Mod. 001-01 / Trasera	3"	0.788"	28 1/2"	28 1/2"	4 3/4"		
39028-K1				0.788"	28 1/2"	28 1/2"			
39028-K2				0.788"	28 1/2"	28 1/2"			
39028-K3				0.788"	28 1/2"	28 1/2"			
39028-K4				0.788"	28 1/2"	28 1/2"			

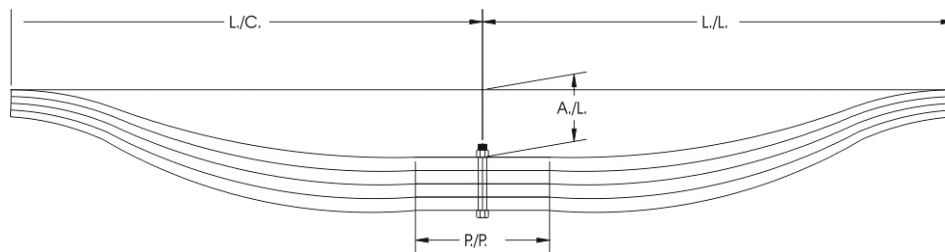

# SANDOVAL	# ORIGINAL	MODELO	ANCHO	ESPESOR	L/C.	L./L.	BRÍO	BUJE L/C	BUJE L./L
39728-K	1996701	Susp.Reyco Mod. 05-07 / Trasera	3"	0.999"	28 1/2"	28 1/2"	4 3/4"		
39728-K1				0.999"	28 1/2"	28 1/2"			
39728-K2				0.999"	28 1/2"	28 1/2"			
39728-K3				0.999"	28 1/2"	28 1/2"			
39728-K4				0.999"	28 1/2"	28 1/2"			

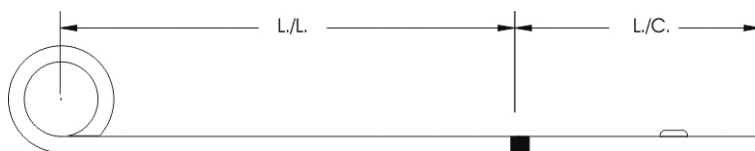

# SANDOVAL	# ORIGINAL	MODELO	ANCHO	ESPEJOR	L./C.	L./L.	BRÍO	BUJE L./C	BUJE L./L
42507-KW	-	Camion T600, 800 Mod. 95-04 / Delantera	4"	0.499"	7 1/2"	3"	Recto	1"	

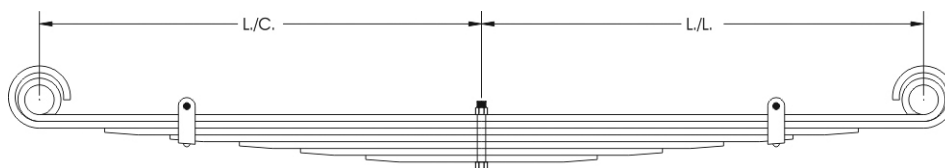

# SANDOVAL	# ORIGINAL	MODELO	ANCHO	ESPEJOR	L./C.	L./L.	BRÍO	BUJE L./C	BUJE L./L
44026	W223C300	Tractocamion T-450 Mod. 67-89 / Delantera	4"	0.401"	26 1/4"	26 1/4"	7 3/8"		
44026-1				0.401"	26 1/4"	26 1/4"		TB-26	TB-26
44026-2				0.401"	26 1/4"	26 1/4"			
44026-3				0.401"	22 3/8"	22 3/8"			
44026-4				0.401"	18 1/2"	18 1/2"			
44026-5				0.401"	14 3/8"	14 3/8"			
44026-6				0.401"	10 3/4"	10 3/4"			
44026-7				0.401"	6 7/8"	6 7/8"			

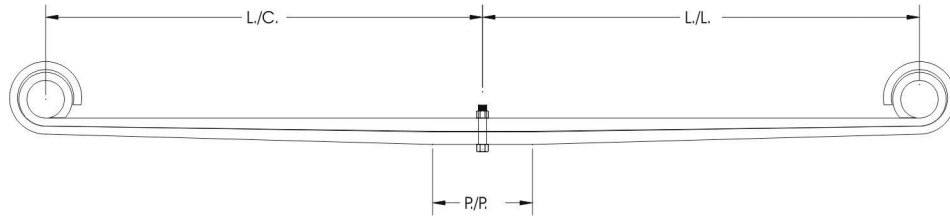

# SANDOVAL	# ORIGINAL	MODELO	ANCHO	ESPESOR	L./C.	L./L.	BRÍO	BUJE L./C	BUJE L./L
48127-KC	K2231125A	Canadiense Mod. 82-06 / Delantera	4"	0.662"	27"	27 1/2"	5"	TB-26	TB-26
48227-KC	K2231125		4"	0.662"	27"	27 1/2"	5"		

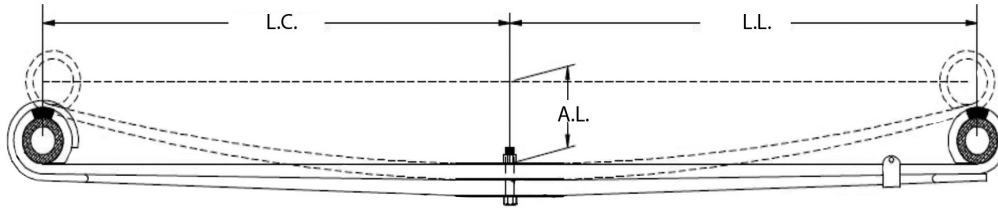

# SANDOVAL	# ORIGINAL	MODELO	ANCHO	ESPESOR	L./C.	L./L.	BRÍO	BUJE L./C	BUJE L./L
49026-FE	-	Americano Mod. 95-04 / Delantera	4"	0.788"	26"	26"	6"		
49026-FE1			4"	0.788"	26"	26"		TB-26 c/ caja	TB-26 c/ caja
49026-FE2			4"	0.788"	26"	27"			

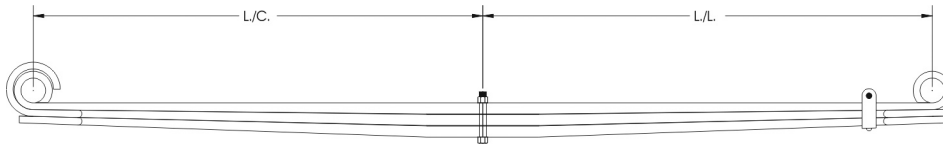

# SANDOVAL	# ORIGINAL	MODELO	ANCHO	ESPESOR	L./C.	L./L.	BRÍO	BUJE L./C	BUJE L./L
49032	K2231073	T800, 600 Mod. 95-04 / Delantera	4"	0.788"	32"	32"	5"		
49032-1			4"	0.788"	32"	32"		TB-26 C/caja	TB-26 C/caja
49032-2				0.788"	32"	33"			
49032-3				0.788"	33"	33"			

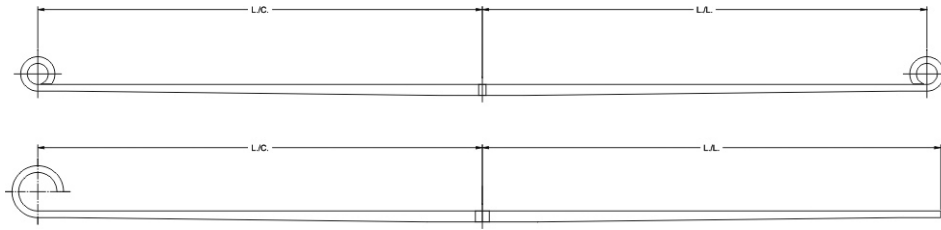

# SANDOVAL	# ORIGINAL	MODELO	ANCHO	ESPESOR	L./C.	L./L.	BRÍO	BUJE L./C	BUJE L./L
49132-K	0202889B	K300, T300 Mod. 93-00 / Delantera	4"	0.788"	32"	32"	5"	RNK	RNK
49232-K				0.788"	32"	33"			

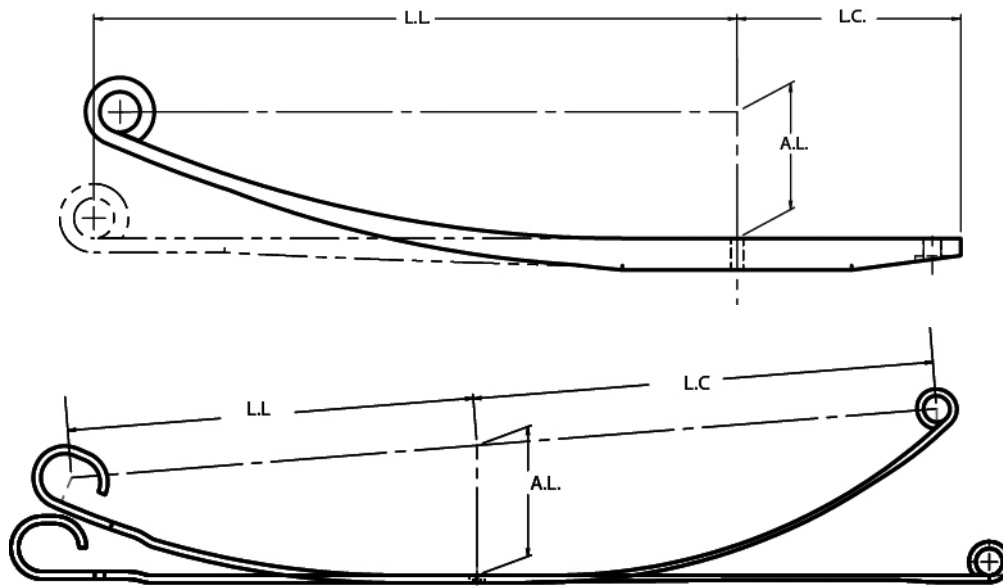

# SANDOVAL	# ORIGINAL	MODELO	ANCHO	ESPESOR	L./C.	L./L.	BRÍO	BUJE L./C	BUJE L./C
49928-KW		Aerocab Mod. 2011-2012 / Delantera	4"	1.375"	28"	9 3/4"	5 1/2"		
49928-KW1				1.375"	28"	9 3/4"		TB-26	
49928-KW2				0.499	28"	33 1/2"			

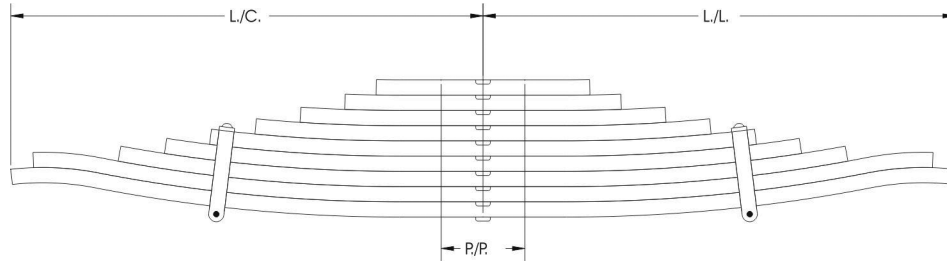

# SANDOVAL	# ORIGINAL	MODELO	ANCHO	ESPESOR	L./C.	L./L.	BRÍO	BUJE L./C	BUJE L./L
50031	K223-C912	T800, 600 Mod. 82-94 / Trasera	4"	0.999"	30 1/2"	30 1/2"	2"		
50031-1				0.999"	30 1/2"	30 1/2"			
50031-2				0.999"	30 1/2"	30 1/2"			
50031-3				0.788"	23 1/16"	23 1/16"			
50031-4				0.788"	18 3/8"	18 3/8"			
50031-5				0.788"	19 1/8"	19 1/8"			
50031-6				0.788"	9 13/16"	9 13/16"			

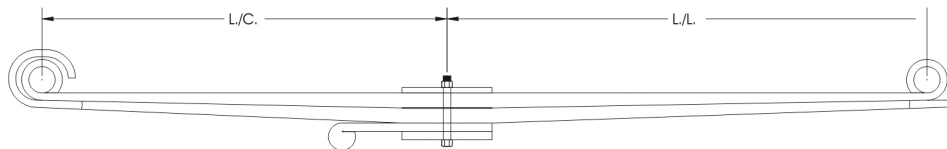

# SANDOVAL	# ORIGINAL	MODELO	ANCHO	ESPESOR	L./C.	L./L.	BRÍO	BUJE L./C	BUJE L./L
50032	HK481102709	T-2000 Mod. 96-06 / Delantera	4"	0.999"	27 1/16"	32 1/8"	4 1/2"		
50032-1				0.999"	27 1/16"	32 1/8"		TB-26 C/ caja	TB-26 C/ caja
50032-1RB				0.999"	27 1/16"	32 1/8"			
50032-2				0.999"	27 1/16"	33"			
50032-3				0.558"	7 1/2"	3"		11/16"	

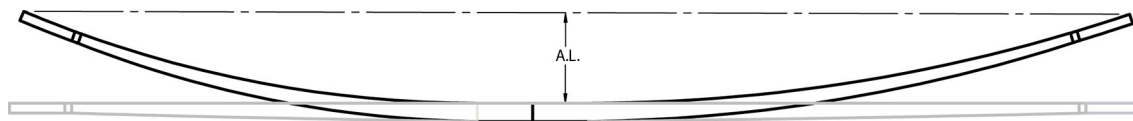

# SANDOVAL	# ORIGINAL	MODELO	ANCHO	ESPESOR	L./C.	L./L.	BRÍO	BUJE L./C	BUJE L./L
50032-3R	C81-6001A	T-2000 Año 2000 Delantera	4"	0.999"	28 3/8"	33"	4.863"	N/A	N/A

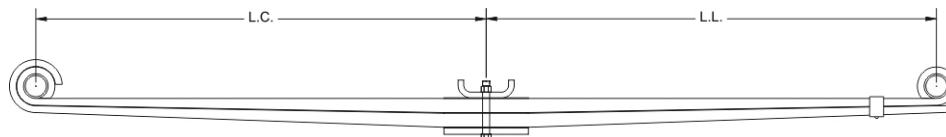

# SANDOVAL	# ORIGINAL	MODELO	ANCHO	ESPESOR	L./C.	L./L.	BRÍO	BUJE L./C	BUJE L./L
50032-KW	HK481101440	T600, T800 Mod. 95-00 / Delantera	4"	0.999"	32"	32"	5 1/4"		
PAD				0.999"	2"	2"			
50032-KW1				0.999"	32"	32"		TB-26 C/ caja	TB-26 C/ caja
50032-KW2				0.999"	32"	33"			
PAD				0.558"	3"	3"			

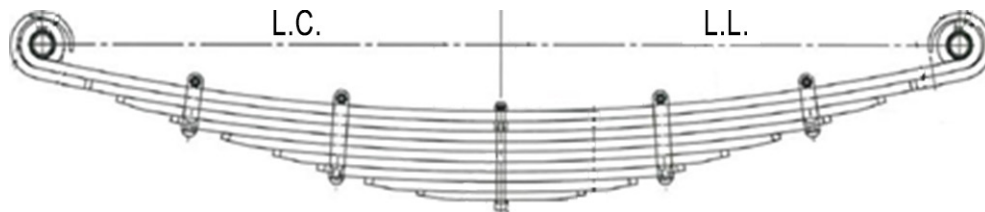

# SANDOVAL	# ORIGINAL	MODELO	ANCHO	ESPESOR	L./C.	L./L.	BRÍO	BUJE L./C	BUJE L./L
59-410	MFG K223-1134	Delantera	4"	0.625"	32"	32"	4.12"		
59-410-1			4"	0.625"	32"	32"		TB-68	TB-68
59-410-2			4"	0.625"	32"	32"			

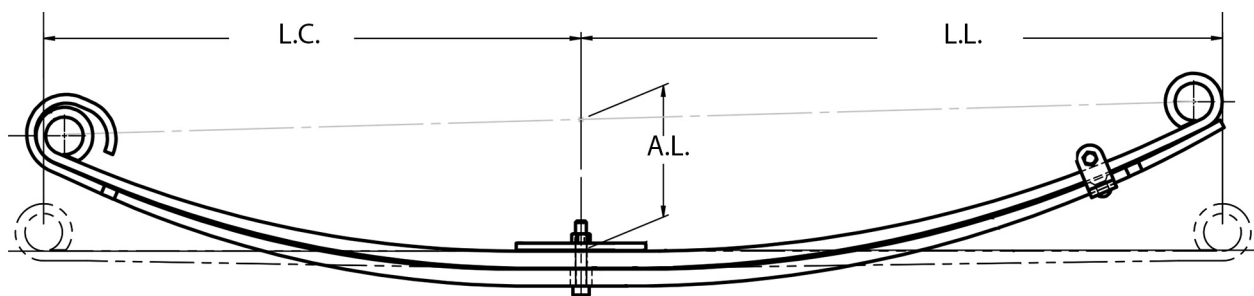

# SANDOVAL	# ORIGINAL	MODELO	ANCHO	ESPESOR	L./C.	L./L.	BRÍO	BUJE L./C	BUJE L./L
59-610	B81-6033	-	4"	0.788"	24 7/8"	29 11/16"	6"		
59-610-1				0.788"	24 7/8"	29 11/16"		RB-338	RB-338
59-610-2				0.788"	24 7/8"	30 3/4"			

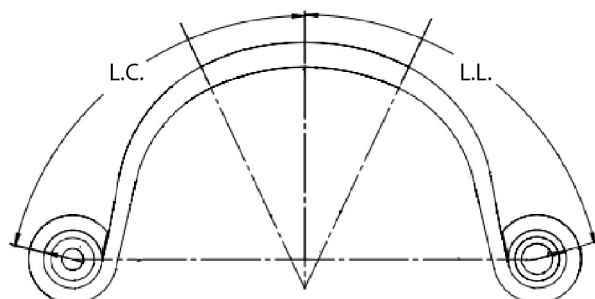

# SANDOVAL	# ORIGINAL	MODELO	ANCHO	ESPESOR	L./C.	L./L.	BRÍO	BUJE L./C	BUJE L./L
75-167	C81-6001A	Air Suspension	4"	0.999"	12 5/8"	12 5/8"	6"	RB-291	RB-292R

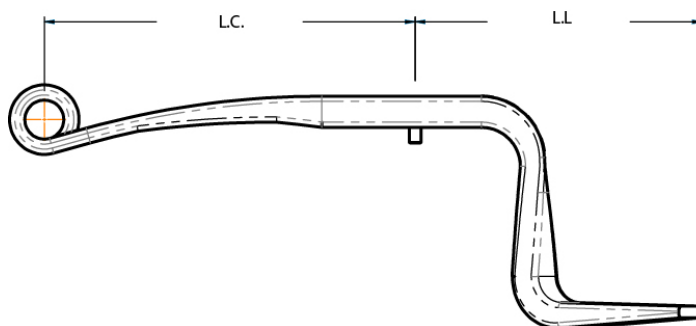

# SANDOVAL	# ORIGINAL	MODELO	ANCHO	ESPESOR	L./C.	L./L.	BRÍO	BUJE L./C	BUJE L./L
KW-0001	-	-	3"	2.000"	23 3/4"	19 1/4"	N/A	-	N/A

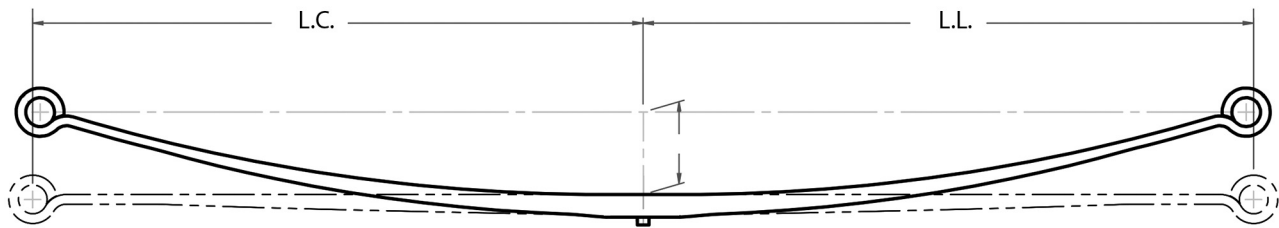

# SANDOVAL	# ORIGINAL	MODELO	ANCHO	ESPESOR	L./C.	L./L.	BRÍO	BUJE L./C	BUJE L./L
KW-0002	C81-6001A	Mod. 2006	3"	1.625"	37 1/4"	37 1/4"	5"	1 3/4"	1 3/4"

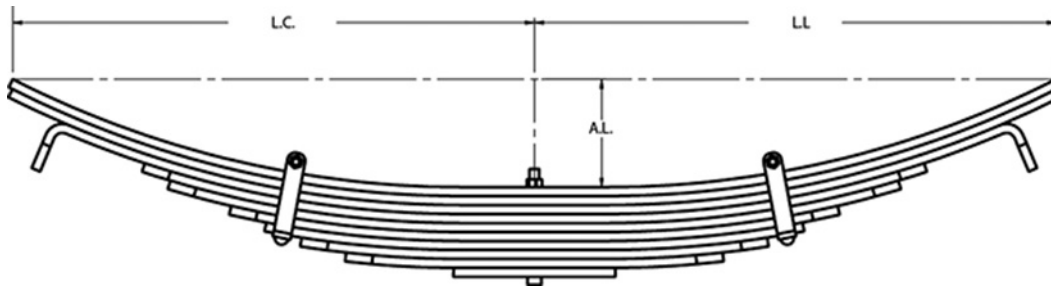

# SANDOVAL	# ORIGINAL	MODELO	ANCHO	ESPESOR	L./C.	L./L.	BRÍO	BUJE L./C	BUJE L./L
KW-0003	-	T-300 Mod. 2003 Adaptación	3"	0.499"	30"	30"	6"	N/A	N/A
KW-0003-1			3"	0.499"	30"	30"			
KW-0003-2			3"	0.499"	30"	30"			
KW-0003-3			3"	0.499"	27 1/2"	27 1/2"			
KW-0003-4			3"	0.499"	22"	22"			
KW-0003-5			3"	0.499"	20 1/2"	20 1/2"			
KW-0003-6			3"	0.499"	17"	17"			
KW-0003-7			3"	0.499"	15"	15"			
KW-0003-8			3"	0.499"	13"	13"			
KW-0003-9			3"	0.499"	6 1/2"	6 1/2"			
KW-0003-10			3"	0.499"	4 1/2"	4 1/2"			

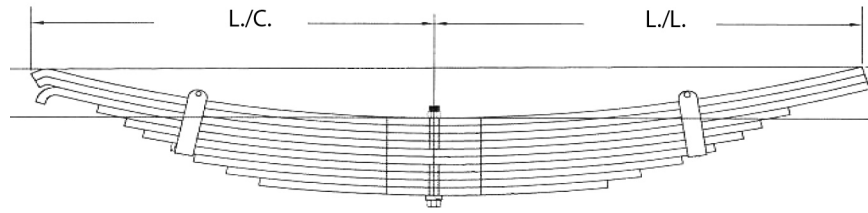

# SANDOVAL	# ORIGINAL	MODELO	ANCHO	ESPEJOR	L./C.	L./L.	BRÍO	BUJE L./C	BUJE L./L
32023-L	-	Tandem Mod. 89-05 / Trasera	3"	0.499"	21 3/4"	23"	LC 3 1/8 LL 3 3/8		
32023-L1				0.499"	21 3/4"	23"			
32023-L2				0.499"	21 3/4"	23"			
32023-L3				0.499"	20 5/8"	23"			
32023-L4				0.499"	18"	19"			
32023-L5				0.499"	16 1/2"	17 1/2"			
32023-L6				0.499"	15 1/2"	16 1/2"			
32023-L7				0.499"	14"	15"			
32023-L8				0.499"	12 1/2"	13 1/4"			
32023-L9				0.499"	11"	11"			
32023-L10				0.499"	9 1/4"	9 1/4"			

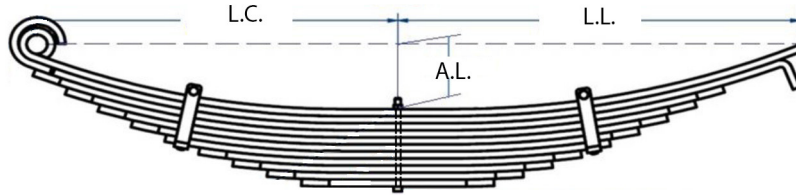

# SANDOVAL	# ORIGINAL	MODELO	ANCHO	ESPESOR	L./C.	L./L.	BRÍO	BUJE L./C	BUJE L./L
62-023	4QK3212	-	3"	0.558"	27 1/8"	30 7/8"	5 1/8"		
62-023-1			3"	0.558"	27 1/8"	30 7/8"		BB-MB-2	
62-023-2			3"	0.558"	27 1/8"	28 1/2"			
62-023-3			3"	0.558"	27"	24"			
62-023-4			3"	0.558"	24 1/2"	21 7/8"			
62-023-5			3"	0.558"	22"	19 3/4"			
62-023-6			3"	0.558"	19 1/2"	17 5/8"			
62-023-7			3"	0.558"	17"	15 1/2"			
62-023-8			3"	0.558"	14 1/2"	13 3/8"			
62-023-9			3"	0.558"	12"	11 1/4"			
62-023-10			3"	0.558"	9 1/2"	9 1/8"			
62-023-11			3"	0.558"	7"	7"			

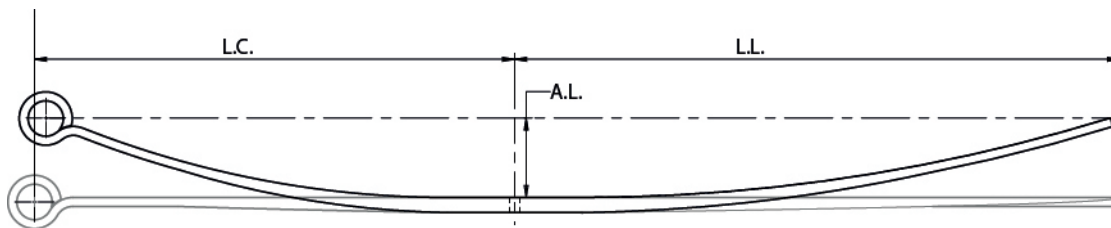

# SANDOVAL	# ORIGINAL	MODELO	ANCHO	ESPESOR	L./C.	L./L.	BRÍO	BUJE L./C	BUJE L./L
MK-0001-1	-	Delantera	3 1/2"	0.788"	25"	31 1/2"	4 1/8"	1 3/4"	1 3/4"

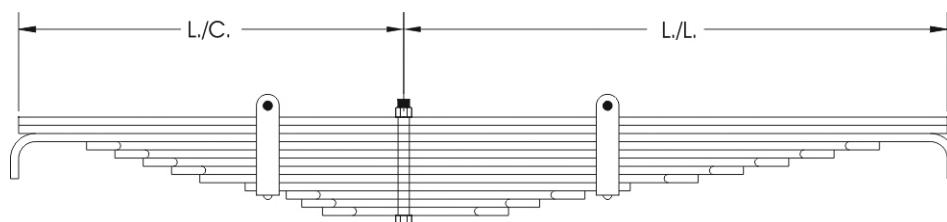

# SANDOVAL	# ORIGINAL	MODELO	ANCHO	ESPESOR	L./C.	L./L.	BRÍO	BUJE L./C	BUJE L./L
32028	NCM12	Eje Tandem, Remolque MCM Mod. 77-83 / Trasera	3"	0.499"	22"	28"	4 1/2"		
32028-1				0.499"	22"	28"			
32028-2				0.499"	22"	28"			
32028-3				0.499"	21"	27"			
32028-4				0.499"	19"	25"			
32028-5				0.499"	17 1/4"	22 1/2"			
32028-6				0.499"	15 1/2"	20"			
32028-7				0.499"	13 3/4"	17 1/2"			
32028-8				0.499"	12"	15"			
32028-9				0.499"	10 1/4"	12 1/2"			
32028-10				0.499"	8"	10"			
32028-11				0.499"	6 1/4"	7 1/2"			
32028-12				0.447"	4 1/2"	5"			

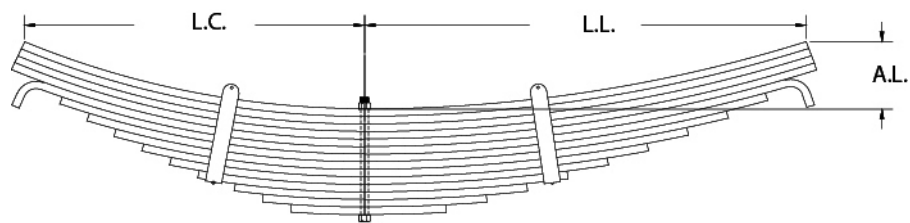

# SANDOVAL	# ORIGINAL	MODELO	ANCHO	ESPESOR	L./C.	L./L.	BRÍO	BUJE L./C	BUJE L./L
32028M		Eje Tandem Mod. 77-83 / Trasera	3"	0.499"	22"	28"	4 1/2"		
32028M-1				0.499"	22"	28"			
32028M-2				0.499"	22"	28"			
32028M-3				0.499"	22"	28"			
32028M-4				0.499"	22"	28"			
32028M-5				0.499"	21"	27"			
32028M-6				0.499"	19"	25"			
32028M-7				0.499"	17 1/4"	22 1/2"			
32028M-8				0.499"	15 1/2"	20"			
32028M-9				0.499"	13 3/4"	17 1/2"			
32028M-10				0.499"	12"	15"			
32028M-11				0.499"	10 1/4"	12 1/2"			
32028M-12				0.499"	8"	10"			
32028M-13				0.499"	6 1/4"	7 1/2"			
32028M-14				0.447"	4 1/2"	5"			

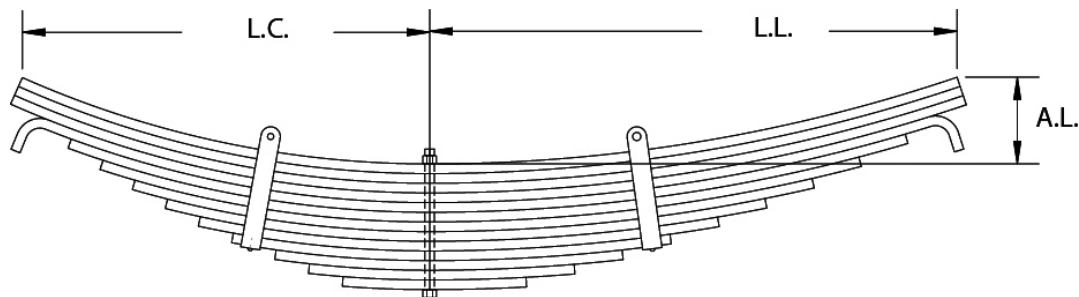

# SANDOVAL	# ORIGINAL	MODELO	ANCHO	ESPESOR	L./C.	L./L.	BRÍO	BUJE L./C	BUJE L./L
32028-R		Eje Tandem Mod. 77-83 / Trasera	3"	0.499"	22"	28"	4 1/2"		
32028-R1				0.499"	22"	28"			
32028-R2				0.499"	22"	28"			
32028-R3				0.499"	22"	28"			
32028-R4				0.499"	21"	27"			
32028-R5				0.499"	19"	25"			
32028-R6				0.499"	17 1/4"	22 1/2"			
32028-R7				0.499"	15 1/2"	20"			
32028-R8				0.499"	13 3/4"	17 1/2"			
32028-R9				0.499"	12"	15"			
32028-R10				0.499"	10 1/4"	12 1/2"			
32028-R11				0.499"	8"	10"			
32028-R12				0.499"	6 1/4"	7 1/2"			
32028-R13				0.477"	4 1/2"	5"			

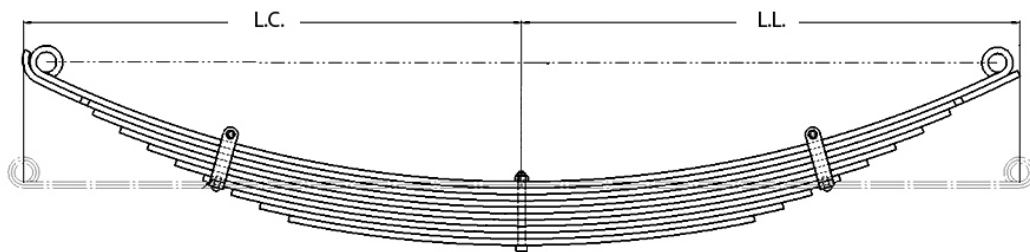

# SANDOVAL	# ORIGINAL	MODELO	ANCHO	ESPESOR	L./C.	L./L.	BRÍO	BUJE L./C	BUJE L./L
24734M-MB	3763200402	Torino Urbano Mod. 2012 / Delantera	70 mm	11 mm	34"	34"	8 1/8"		
24734M-MB1				11 mm	34"	34"		BM-M73025	BM-M73025
24734M-MB2				11 mm	34"	35"			
24734M-MB3				11 mm	30"	30"			
24734M-MB4				11 mm	28"	28"			
24734M-MB5				11 mm	26"	26"			
24734M-MB6				11 mm	24"	24"			
24734M-MB7				11 mm	22"	22"			
24734M-MB8				11 mm	20"	20"			
24734M-MB9				11 mm	18"	18"			
24734M-MB10				11 mm	16"	16"			



# SANDOVAL	# ORIGINAL	MODELO	ANCHO	ESPESOR	L./C.	L./L.	BRÍO	BUJE L./C	BUJE L./L
28729-SP	-	Sprinter 416 Doble rodado Mod. 04-05 / Trasera	70mm	13mm	29 1/4"	29 3/4"	6"		
28729-SP1				13 mm	29 1/4"	29 3/4"		RB-278	RB-279
28729-SP2				11 mm	27"	27 1/2"			
28729-SP3				15 mm	26 1/4"	26 1/4"			
28729-SP4				28 mm	26 1/4"	26 1/4"			
28729-SP5				11 mm	20 1/4"	24"			
28729-SP6				11 mm	14 1/2"	14 1/2"			

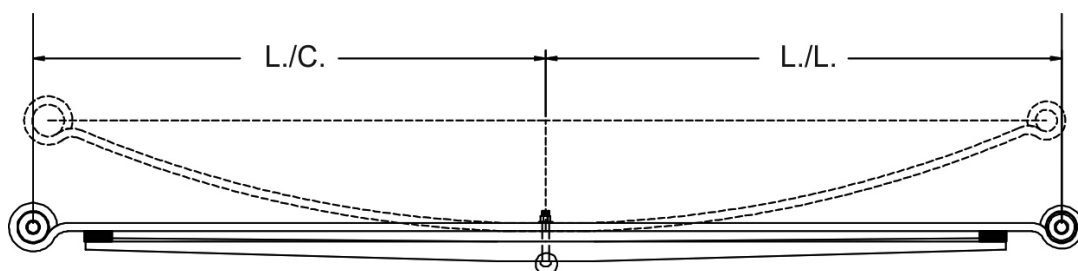

# SANDOVAL	# ORIGINAL	MODELO	ANCHO	ESPESOR	L./C.	L./L.	BRÍO	BUJE L./C	BUJE L./L
28729-ST	05118621AA / 9043201606	Sprinter 416 doble rodado Mod. 04-05 / Trasera	70mm	13mm	29 1/4"	29 1/2"	5 13/16"		
28729-ST1				13 mm	29 1/4"	29 1/2"		RB-279	RB-279
28729-ST2				15 mm	26 1/4"	26 1/4"			
28729-ST3				28 mm	26 1/4"	26 1/4"			

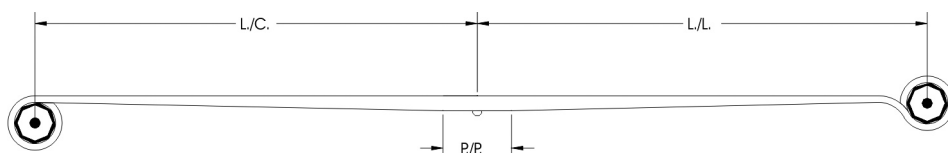

# SANDOVAL	# ORIGINAL	MODELO	ANCHO	ESPESOR	L./C.	L./L.	BRÍO	BUJE L./C	BUJE L./L
28929-FG	9033202306	Sprinter 316 Mod. 04-08 / Trasera	70 mm	25 mm	29 1/4"	29 3/4"	4 5/8"	RB-277	RB-277

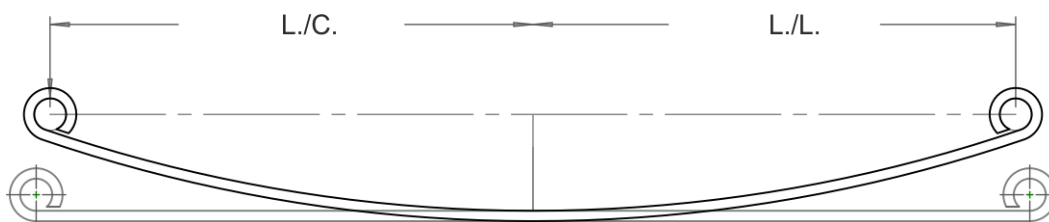

# SANDOVAL	# ORIGINAL	MODELO	ANCHO	ESPESOR	L./C.	L./L.	BRÍO	BUJE L./C	BUJE L./L
306037-MB1	345.320.7606	Paq. Trasero 1984-92	80 mm	13 mm	37 1/2"	37 1/2"	5"	35 mm	35 mm

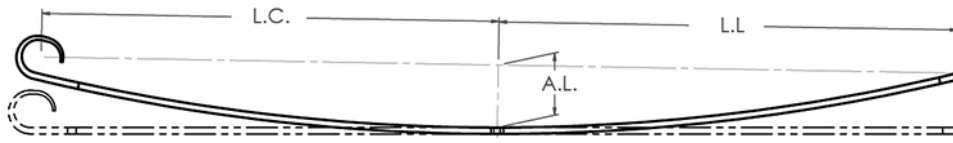

# SANDOVAL	# ORIGINAL	MODELO	ANCHO	ESPESOR	L./C.	L./L.	BRÍO	BUJE L./C	BUJE L./L
306037-MB2	345.320.7606	Paq. Trasero 1984-92	80 mm	13 mm	37 1/2"	37 1/2"	5"	-	-

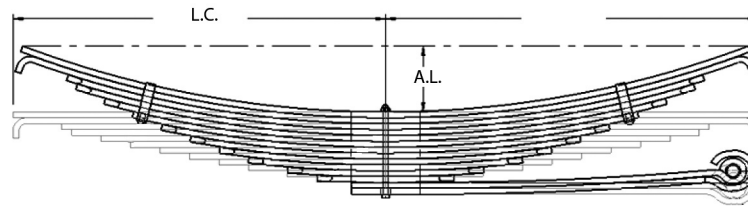

# SANDOVAL	# ORIGINAL	MODELO	ANCHO	ESPESOR	L./C.	L./L.	BRÍO	BUJE L./C	BUJE L./L
36038-B	-	Torino Mod. 2009 / Trasera	3"	0.625"	38"	38"	7"		
36038-MB1				0.625"	38"	38"	7"		
36038-MB2				0.625"	37 3/8"	37 3/8"	7"		
36038-MB3				0.625"	33"	33"	7"		
36038-MB4				0.625"	32"	32"	7"		
36038-MB5				0.625"	29"	29"	7"		
36038-MB6				0.625"	26"	26"	7"		
36038-MB7				0.625"	23"	23"	7"		
36038-MB8				0.625"	20"	20"	7"		
36038-MB9				0.625"	17"	17"	7"		
36038-MB10				0.625"	14"	14"	7"		
36038-MB11				0.625"	10"	10"	7"		
36038-MB12				0.625"	7"	7"	7"		
36038-MB13				0.625"	3 1/2"	35 1/2"	1 1/4"		BB-RNG
36038-MB14				0.625"	3 1/2"	35 1/2"	1 1/4"		

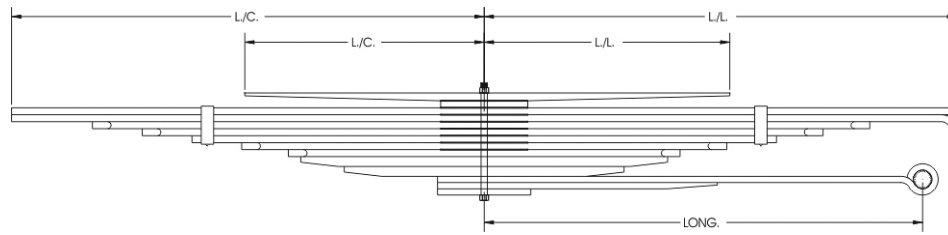

# SANDOVAL	# ORIGINAL	MODELO	ANCHO	ESPESOR	L./C.	L./L.	BRÍO	BUJE L./C	BUJE L./L
38038-M	MBT1218M	Autobus Largo Mod. 99 / Trasera	3"	0.558"	38"	38"	7"		
38038-M01				0.625"	19 1/4"	19 3/4"	4"		
PAD				0.558"	3 1/2"	3 1/2"	-		
38038-M1				0.558"	38"	38"	7"		
38038-M2				0.558"	38"	37 1/2"	7"		
38038-M3				0.558"	31 1/2"	31"	7"		
38038-M4				0.558"	27 1/2"	27 1/2"	7"		
38038-M5				0.558"	23 1/2"	23 1/2"	7"		
38038-M6				0.558"	19 1/2"	19 1/2"	7"		
38038-M7				0.558"	15 3/4"	15 3/4"	7"		
38038-M8				0.788"	14 3/4"	14 3/4"	1/2"		
38038-M9				0.788"	11 1/4"	11 1/4"	1/2"		
38038-M10				0.558"	3 3/4"	35 1/4"	1 1/4"		BM-RNG
38038-M11				0.558"	3 3/4"	18 3/4"	1 1/4"		
PAD				0.499"	3 3/4"	3 3/4"	-		

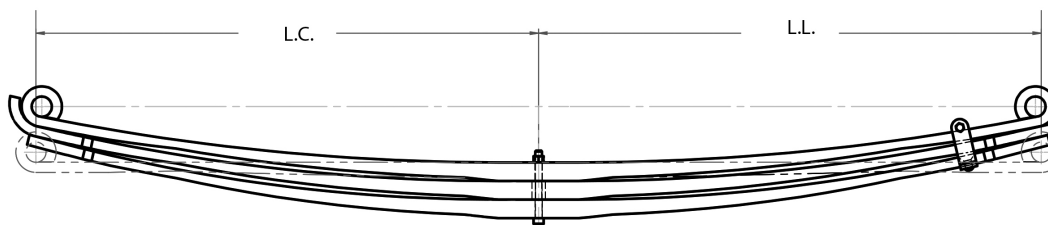

# SANDOVAL	# ORIGINAL	MODELO	ANCHO	ESPESOR	L./C.	L./L.	BRÍO	BUJE L./C	BUJE L./C
39937-MB	3763200408	Minitorino Mod. 2010 / Trasera	80mm	35 mm	37 3/8"	37 3/8"	4 1/8"		
39937-MB1				0.625"	37 3/8"	37 3/8"	4"	BB-M83530	BB-M83530
39937-MB2				0.558"	37 3/8"	37 3/8"	-		
39937-MB3				0.558"	38 3/8"	38 3/8"	7"		

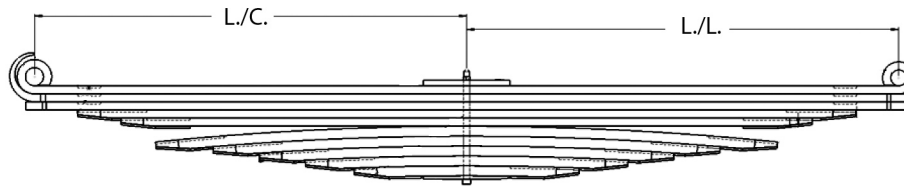

# SANDOVAL	# ORIGINAL	MODELO	ANCHO	ESPESOR	L./C.	L./L.	BRÍO	BUJE L./C	BUJE L./L
40744-MB	3453200008	Urbano Mod. 2010 / Trasera	80 mm	18 mm	952 mm	952 mm	Recto		
PAD				12 mm	95 mm	95 mm			
40744-MB-1				18 mm	952 mm	952 mm	Recto	BM-M83530	BM-M83530
40744-MB-2				18 mm	950 mm	971 mm	Recto		
40744-MB-3				18 mm	971 mm	971 mm	Recto		
40744-MB-4				18 mm	857 mm	857 mm	Recto		
40744-MB-5				18 mm	762 mm	762 mm	Recto		
40744-MB-6				22 mm	686 mm	686 mm	1 3/8" Inv.		
40744-MB-7				22 mm	559 mm	559 mm	1 3/8" Inv		
40744-MB-8				22 mm	457 mm	457 mm	1 3/8" Inv		
40744-MB-9				22 mm	356 mm	356 mm	1 3/8" Inv		
40744-MB-10				22 mm	248 mm	248 mm	1 3/8" Inv		
CUÑA				12 mm	95 mm	95 mm			

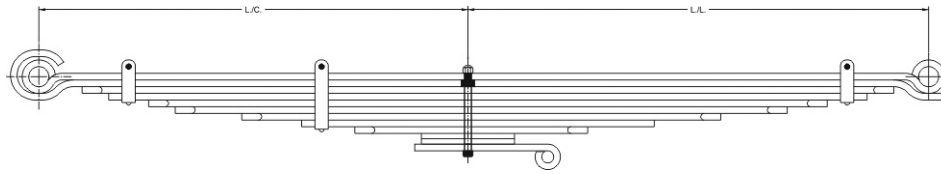

# SANDOVAL	# ORIGINAL	MODELO	ANCHO	ESPESOR	L./C.	L./L.	BRÍO	BUJE L./C	BUJE L./L
42032-MB	LM6853203602	Autobus Torino Mod. 02-06 / Delantera	4"	0.499"	32 1/4"	34 5/8"	6 1/2"		
42032-MB1				0.499"	32 1/4"	34 5/8"		BM-RNK	BM-RNK
42032-MB2				0.499"	32 1/4"	34 5/8"			
42032-MB3				0.499"	29"	32"			
42032-MB4				0.499"	27"	30"			
42032-MB5				0.499"	24"	27"			
42032-MB6				0.499"	22"	24"			
42032-MB7				0.499"	17"	19"			
42032-MB8				0.499"	12 1/2"	14"			
42032-MB9				0.499"	8 1/2"	9"			
42032-MB10				0.401"	3 1/2"	3 1/2"			
42032-MB11				0.401"	3 1/2"	3 1/2"			
42032-MB12				0.499"	4"	6"			0.9"

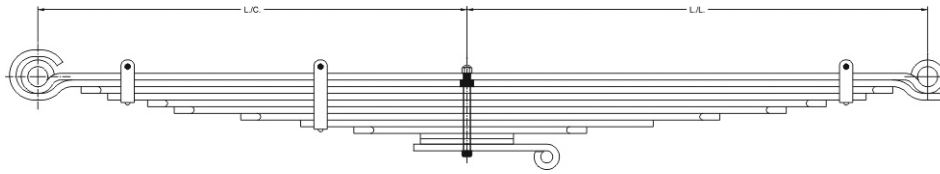

# SANDOVAL	# ORIGINAL	MODELO	ANCHO	ESPESOR	L./C.	L./L.	BRÍO	BUJE L./C	BUJE L./L
42032M-MB	LM6853203602	Autobus Torino Mod. 02-06 / Delantera	4"	0.499"	32 1/4"	34 5/8"	5 1/2"		
42032M-MB1				0.499"	32 1/4"	34 5/8"		BM-RNK	BM-RNK
42032M-MB2				0.499"	32 1/4"	34 5/8"			
42032M-MB3				0.499"	29"	32"			
42032M-MB4				0.499"	27"	30"			
42032M-MB5				0.499"	24"	27"			
42032M-MB6				0.499"	22"	24"			
42032M-MB7				0.499"	17"	19"			
42032M-MB8				0.499"	12 1/2"	14"			
42032M-MB9				0.499"	8 1/2"	9"			
42032M-MB10				0.401"	3 1/2"	3 1/2"			
42032M-MB11				0.401"	3 1/2"	3 1/2"			
42032M-MB12				0.499"	4"	6"			0.9"

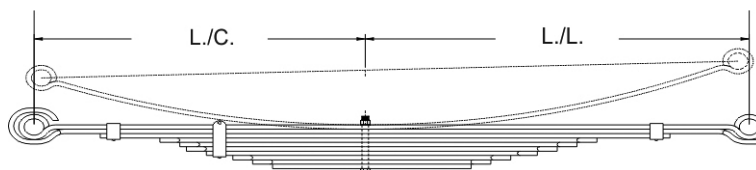

# SANDOVAL	# ORIGINAL	MODELO	ANCHO	ESPESOR	L./C.	L./L.	BRÍO	BUJE L./C	BUJE L./L
44029-GR	471275C92	F1300, 1500 Mod. 92-98 / Delantera	4"	0.401"	25"	29"	5"		
44029-GR1				0.401"	25"	29"		BM-RNK	BM-RNK
44029-GR2				0.401"	25"	29"			
44029-GR3				0.401"	20"	23"			
44029-GR4				0.401"	15 1/2"	17 1/2"			
44029-GR5				0.401"	14"	16"			
44029-GR6				0.401"	13 1/2"	14 1/2"			
44029-GR7				0.401"	12"	13"			
44029-GR8				0.401"	10"	11"			
44029-GR9				0.401"	8 1/2"	9 1/2"			
44029-GR10				0.401"	7"	8"			

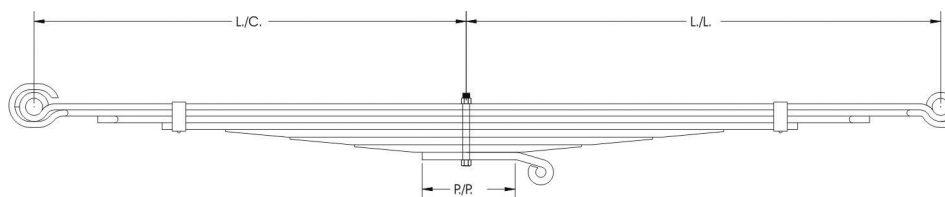

# SANDOVAL	# ORIGINAL	MODELO	ANCHO	ESPESOR	L./C.	L./L.	BRÍO	BUJE L./C	BUJE L./L
47033-E	LM6853203802	Camion Largo Mod. 99-05 / Delantera	4"	0.447"	28"	33"	6 1/2"		
47033-E1				0.447"	28"	33"		BM-RNK	BM-RNK
47033-E2				0.447"	28"	33"			

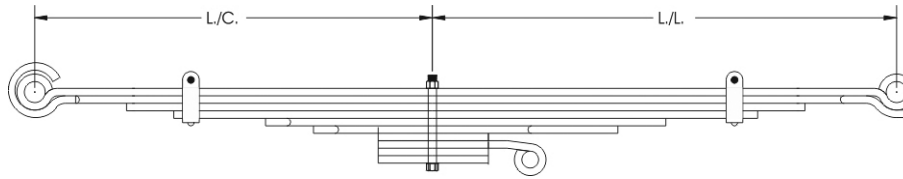

# SANDOVAL	# ORIGINAL	MODELO	ANCHO	ESPESOR	L./C.	L./L.	BRÍO	BUJE L./C	BUJE L./L
47033-M	ML6853203802	Urbano Largo Mod. 99-05 / Delantera	4"	0.447"	28"	33"	6 1/2"		
47033-M1				0.447"	28"	33"		BM-NJK	BM-NJK
47033-M2				0.447"	28"	33"			
47033-M3				0.447"	22 7/8"	27"			
47033-M3R				0.447"	25"	29"	5 1/2"		
47033-M4				0.447"	17 3/4"	20 7/8"			
47033-M5				0.447"	12 5/8"	14 3/4"			
47033-M6				0.447"	7 5/8"	8 5/8"			
47033-M7				0.558"	3 1/4"	3 1/4"			
47033-M8				0.558"	3 1/4"	5 5/8"			3/4"
47033-M9				0.401"	3 1/4"	3 1/4"			
47033-M10				0.401"	3 1/4"	3 1/4"			

# SANDOVAL	# ORIGINAL	MODELO	ANCHO	ESPESOR	L./C.	L./L.	BRÍO	BUJE L./C	BUJE L./L
47033M-M	-	Tipo Tandem / Trasera	4"	0.447"	28"	33"	6 1/2"		
47033-M-M1				0.447"	28"	33"		BM-RNK	BM-RNK
47033-M-M2				0.447"	28"	33"			
47033-M-M3				0.447"	22 7/8"	27"			
47033-M-M4				0.447"	17 3/4"	20 7/8"			
47033-M-M5				0.447"	12 5/8"	14 3/4"			
47033-M-M6				0.447"	7 5/8"	8 5/8"			
PAD				0.558"	3 1/4"	3 1/4"			
47033-M-M01				0.558"	3 1/4"	5 5/8"			3/4"
PAD				0.401"	3 1/4"	3 1/4"			
PAD				0.401"	3 1/4"	3 1/4"			

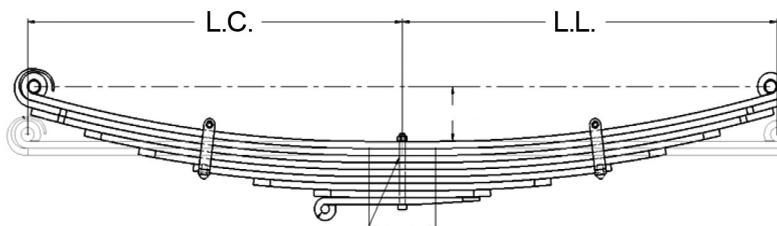

# SANDOVAL	# ORIGINAL	MODELO	ANCHO	ESPEJOR	L./C.	L./L.	BRÍO	BUJE L./C	BUJE L./L
701534-MB	3683200605	LPS1525 Mod. 99-05 / Delantera	70 mm	15 mm	34"	34"	4 5/8"		
701534-MB1				15 mm	34"	34"		BM-M73025	BM-M73025
701534-MB2				15 mm	34"	34 1/2"			
701534-MB3				15 mm	34"	34"			
701534-MB4				15 mm	29"	29"			
701534-MB5				15 mm	24"	24"			
701534-MB6				15 mm	19"	19"			
701534-MB7				15 mm	13 1/2"	13 1/2"			
701534-MB8				15 mm	8"	8"			
701534-MB9				15 mm	7"	7"		3/4"	

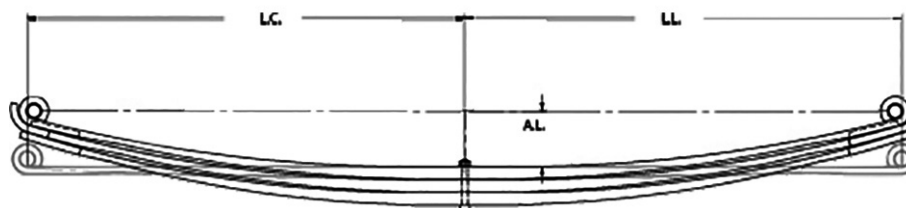

# SANDOVAL	# ORIGINAL	MODELO	ANCHO	ESPEJOR	L./C.	L./L.	BRÍO	BUJE L./C	BUJE L./L
702534-MB	-	Boxer Mod. 99-05 / Delantera	70 mm	25 mm	34"	34"	4 1/2"		
702534-MB1				25 mm	34"	34"		BM-M73025	BM-M73025
702534-MB2				25 mm	34"	35"			
702534-MB3				25 mm	35"	35"			

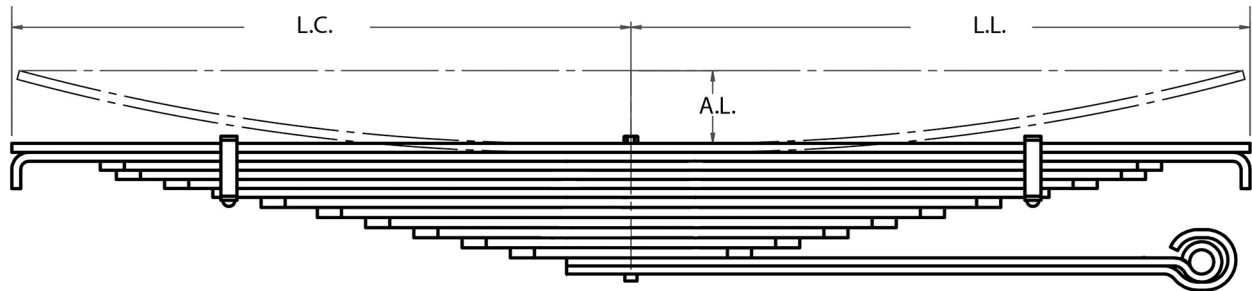

# SANDOVAL	# ORIGINAL	MODELO	ANCHO	ESPESOR	L./C.	L./L.	BRÍO	BUJE L./C	BUJE L./L
MB-0005	Adaptacion	Torino Mod. 2006-2009	3"	0.558"	38 1/2"	38 1/2"	4 1/2"		
MB-0005-1			3"	0.558"	38 1/2"	38 1/2"			
MB-0005-2			3"	0.558"	38 1/2"	38 1/2"			
MB-0005-3			3"	0.558"	33"	33"			
MB-0005-4			3"	0.558"	32"	32"			
MB-0005-5			3"	0.558"	29"	29"			
MB-0005-6			3"	0.558"	26"	26"			
MB-0005-7			3"	0.625"	23"	23/2"			
MB-0005-8			3"	0.625"	19 1/2"	19 1/2"			
MB-0005-9			3"	0.625"	16 1/2	16 1/2			
MB-0005-10			3"	0.625"	13 1/2	13 1/2			
MB-0005-11			3"	0.625"	10 1/2	10 1/2			
MB-0005-12			3"	0.625"	7 1/2	7 1/2			
MB-0005-13			3"	0.449"	4"	35 1/2"			BB-RNG
MB-0005-14			3"	0.449"	4"	35 1/2"			

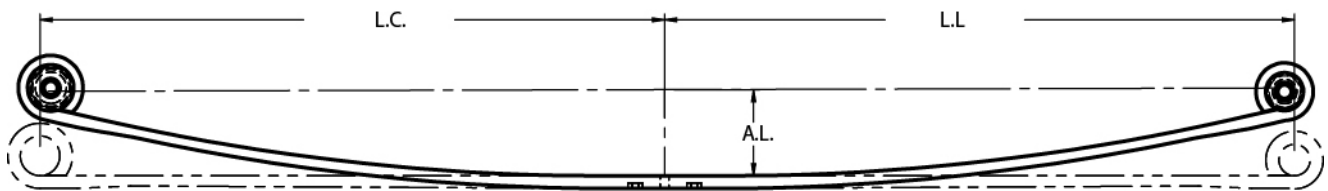

# SANDOVAL	# ORIGINAL	MODELO	ANCHO	ESPESOR	L./C.	L./L.	BRÍO	BUJE L./C	BUJE L./L
MB-0006-1	A9063200206/ Z007		70 mm	25 mm	29 1/4"	29 1/2"	4"	RB-278	RB-279

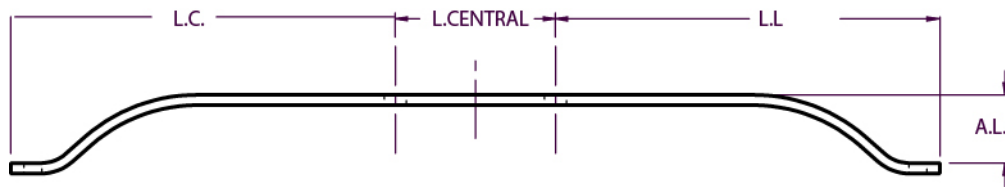

# SANDOVAL	# ORIGINAL	MODELO	ANCHO	ESPESOR	L./C.	L./L.	BRÍO	BUJE L./C	BUJE L./L
MB-0007	A20121898-A	Caja de Velocidades	2.250"	0.401"	14 1/2"	14 1/2"	2 1/8"	N/A	N/A

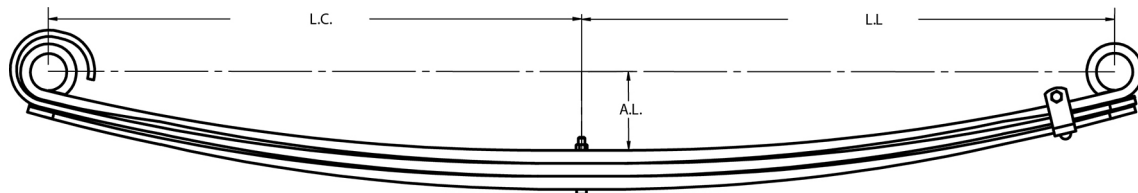

# SANDOVAL	# ORIGINAL	MODELO	ANCHO	ESPESOR	L./C.	L./L.	BRÍO	BUJE L./C	BUJE L./L
MB-0008	9793200202	Toretto	70 mm	19 mm	798 mm	798 mm	115 mm		
MB-0008-1			70 mm	19 mm	798 mm	798 mm		54 mm	54 mm
MB-0008-2			70 mm	19 mm	798 mm	823 mm			
MB-0008-3			70 mm	19 mm	823 mm	823 mm			

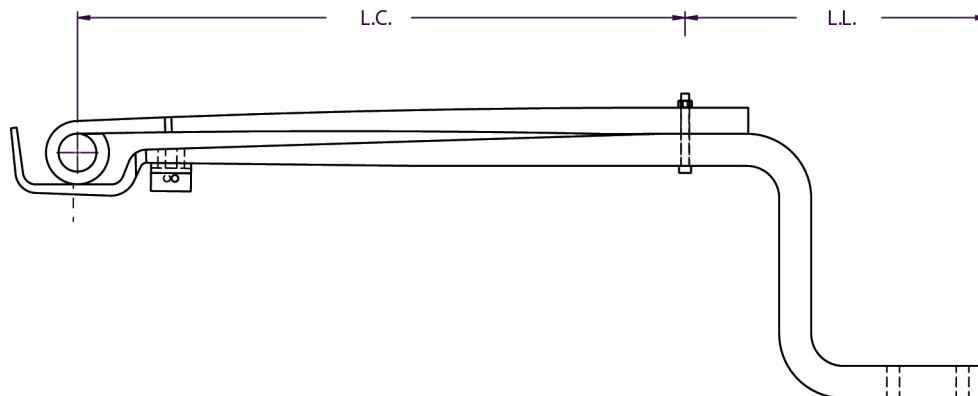

# SANDOVAL	# ORIGINAL	MODELO	ANCHO	ESPESOR	L./C.	L./L.	BRÍO	BUJE L./C	BUJE L./L
MB-0009	9793200202	Alce. Mod. 2000	76 mm	41 mm	965 mm	100 mm	-		
MB-0009-1			76 mm	41 mm	965 mm	100 mm			
MB-0009-2			76 mm	50.8 mm	970 mm	480 mm			

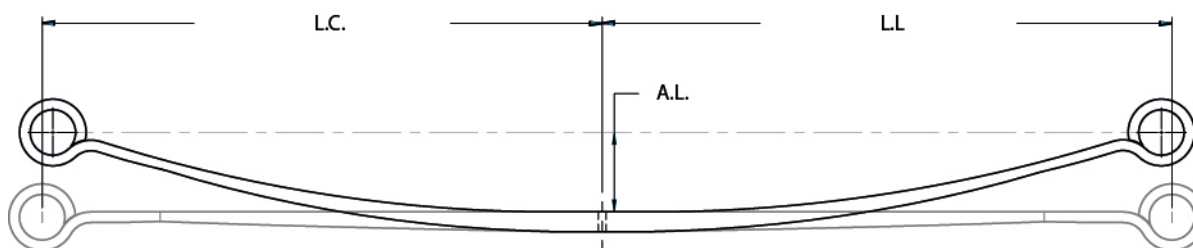

# SANDOVAL	# ORIGINAL	MODELO	ANCHO	ESPESOR	L./C.	L./L.	BRÍO	BUJE L./C	BUJE L./L
MB-0010-1	9063203206	Sprinter	70 mm	26 mm	740 mm	753 mm	104.8	60 mm	60 mm

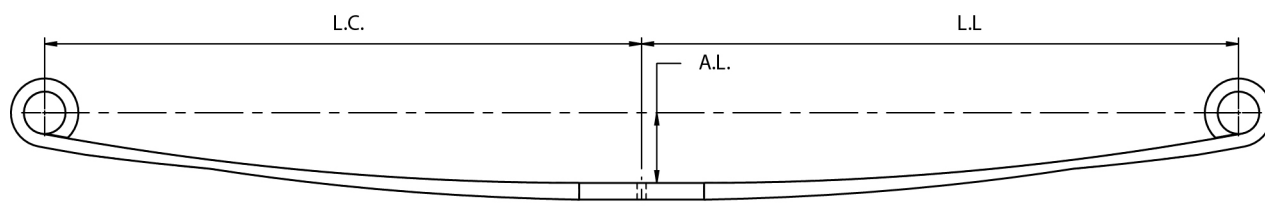

# SANDOVAL	# ORIGINAL	MODELO	ANCHO	ESPESOR	L./C.	L./L.	BRÍO	BUJE L./C	BUJE L./L
MB-0011-1	9793200302	TORETTO 2017-2018	70 mm	22 mm	800 mm	800 mm	92	2 3/16"	2 3/16"

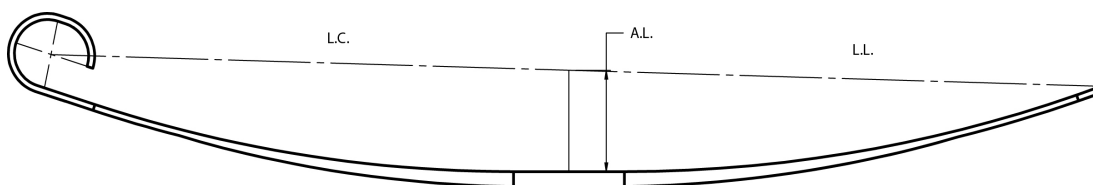

# SANDOVAL	# ORIGINAL	MODELO	ANCHO	ESPESOR	L./C.	L./L.	BRÍO	BUJE L./C	BUJE L./L
MB-0011-2	9793200302	TORETTO 2017-2018	70 mm	22 mm	800 mm	810 mm	150	-	-

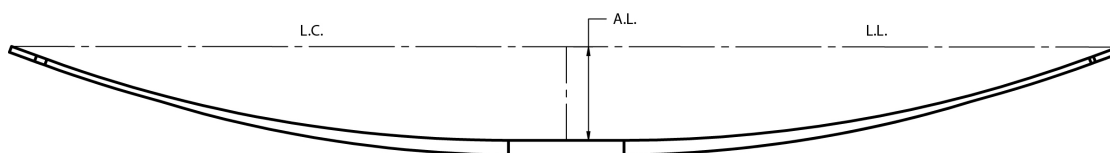

# SANDOVAL	# ORIGINAL	MODELO	ANCHO	ESPESOR	L./C.	L./L.	BRÍO	BUJE L./C	BUJE L./L
MB-0011-3	9793200302	TORETTO 2017-2018	70 mm	22 mm	810 mm	810 mm	136	-	-

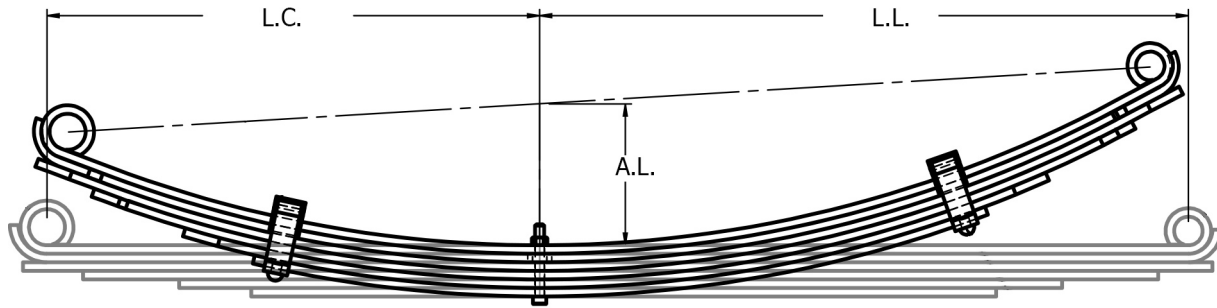

# SANDOVAL	# ORIGINAL	MODELO	ANCHO	ESPESOR	L./C.	L./L.	BRÍO	BUJE L./C	BUJE L./L
24820-MSR	Adaptacion	Pick UP	70 mm	9 mm	20 1/2"	27"	5 7/8"		
24820-MSR-1			70 mm	9 mm	20 1/2"	27"		1 1/2"	1 3/16"
24820-MSR-2			70 mm	9 mm	20 1/2"	27"			
24820-MSR-3			70 mm	9 mm	21 1/2"	28"			
24820-MSR-4			70 mm	9 mm	19"	25 3/4"			
24820-MSR-5			70 mm	9 mm	15"	21 3/4"			
24820-MSR-6			70 mm	9 mm	12"	19"			

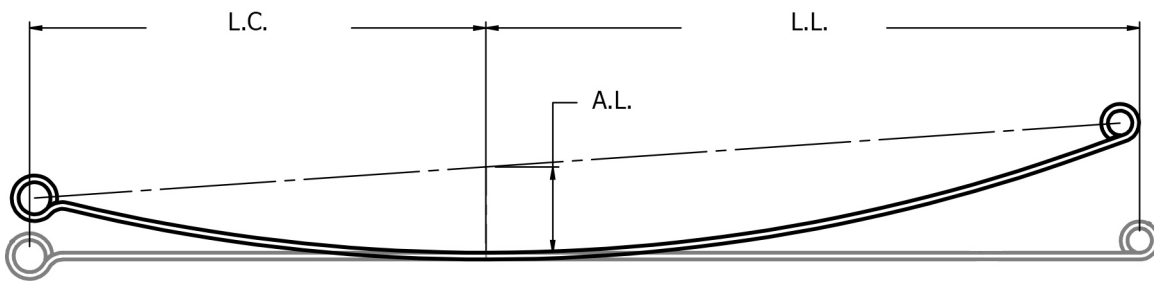

# SANDOVAL	# ORIGINAL	MODELO	ANCHO	ESPESOR	L./C.	L./L.	BRÍO	BUJE L./C	BUJE L./L
MS-0001-1	-	-	60 mm	8 mm	21 3/8"	30 5/8"	4"	38 mm	29 mm

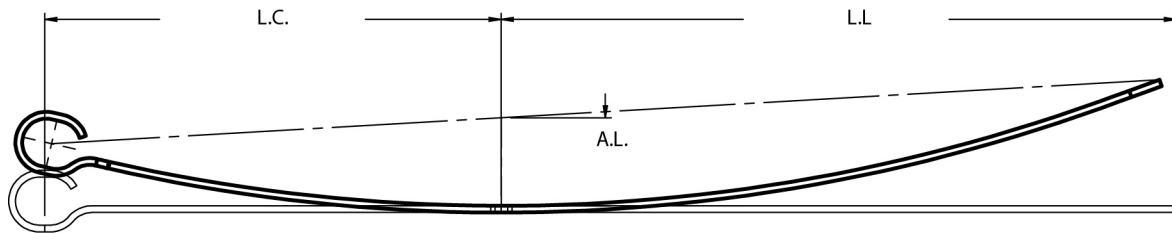

# SANDOVAL	# ORIGINAL	MODELO	ANCHO	ESPEJOR	L./C.	L./L.	BRÍO	BUJE L./C	BUJE L./L
MS-0001-2R	-	2da Refuerzo	60 mm	8 mm	21 3/8"	31 5/8"	4 3/8"	-	-

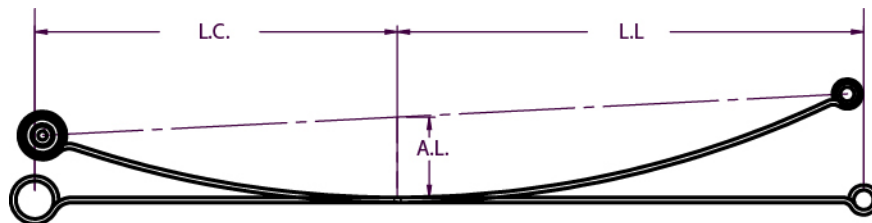

# SANDOVAL	# ORIGINAL	MODELO	ANCHO	ESPEJOR	L./C.	L./L.	BRÍO	BUJE L./C	BUJE L./L
MS-0002-1	-	Pick Up Trasera	60 mm	8 mm	575	740	127	RB	HB

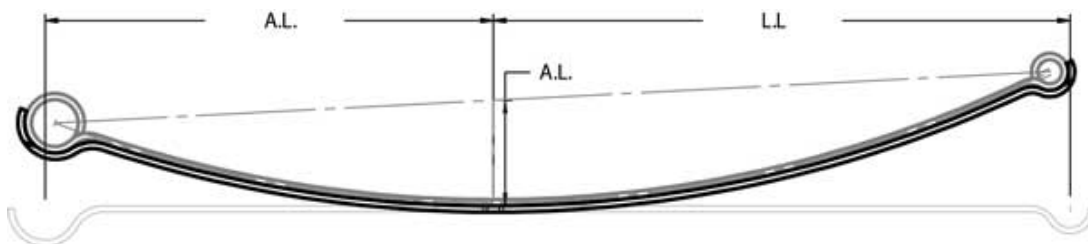

# SANDOVAL	# ORIGINAL	MODELO	ANCHO	ESPEJOR	L./C.	L./L.	BRÍO	BUJE L./C	BUJE L./L
MS-0002-2RD	-	Pick Up Trasera	60 mm	8 mm	575	740	135	N/A	N/A

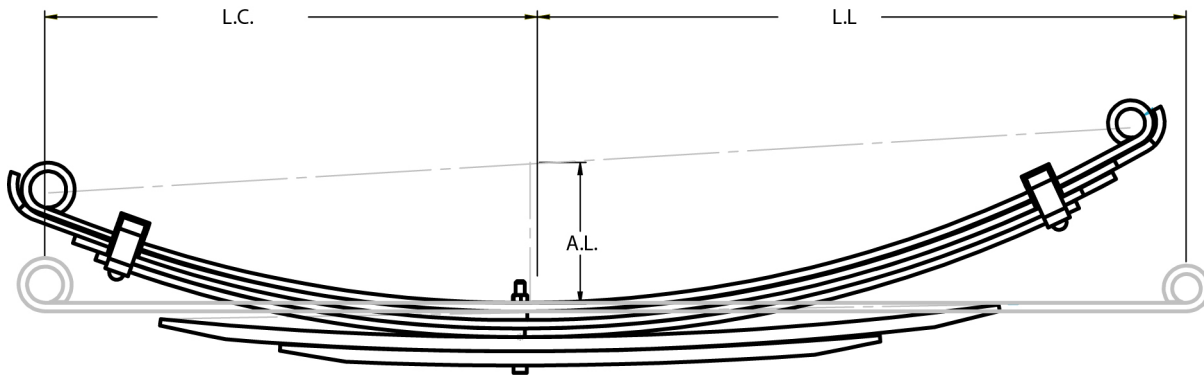

# SANDOVAL	# ORIGINAL	MODELO	ANCHO	ESPESOR	L./C.	L./L.	BRÍO	BUJE L./C	BUJE L./L
MS-0003	-	Pick Up Trasera	70 mm	9 mm	20 1/2"	27"	5 7/8"		
MS-0003-1			70 mm	9 mm	20 1/2"	27"		1 1/2"	1 3/16"
MS-0003-2			70 mm	9 mm	20 1/2"	27"			
MS-0003-3			70 mm	9 mm	19	25 3/4"			
MS-0003-4			70 mm	9 mm	18	24"			
MS-0003-5			70 mm	15 mm	15	20"			
MS-0003-6			70 mm	15 mm	10	15"			

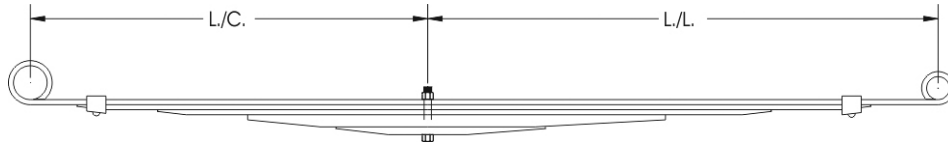

# SANDOVAL	# ORIGINAL	MODELO	ANCHO	ESPESOR	L./C.	L./L.	BRÍO	BUJE L./C	BUJE L./L
20022	5502025WGOM	Datsun Pick Up 1800 Mod. 73 / Trasera	60 mm	8 mm	22 1/4"	25"	5 1/4"		
20022-1				8 mm	22 1/4"	25"		Goma 763	Goma763
20022-2				8mm	20 3/8"	22 3/4"			
20022-2RD				8 mm	22 1/4"	25 1/4"	5 7/8"		
20022-3				7 mm	17 3/4"	19 5/8"			
20022-4				16 mm	12 5/8"	14 1/2"			
20022-5				10 mm	8 1/2"	9 3/4"			

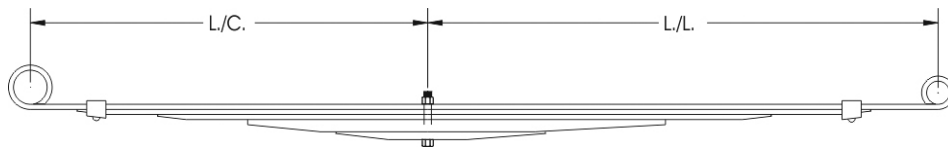

# SANDOVAL	# ORIGINAL	MODELO	ANCHO	ESPESOR	L./C.	L./L.	BRÍO	BUJE L./C	BUJE L./L
20023	55020C07G1M	Pick Up 1800 Mod. 93-98 / Trasera	60 mm	8 mm	23 1/2"	23 1/2"	5"		
20023-1				8 mm	23 1/2"	23 1/2"	5"	Goma 763"	Goma 763
20023-2				8mm	21 7/8"	21 7/8"	5"		
20023-2R				8 mm	23 1/2"	23 1/2"	5"		
20023-2RD				8 mm	23 1/2"	23 1/2"	5 1/2"		
20023-2RE				8 mm	23 1/2"	23 1/2"	5"		
20023-3				14 mm	18"	18"	Recto		
20023-4				14 mm	9 1/2"	9 1/2"	Recto		

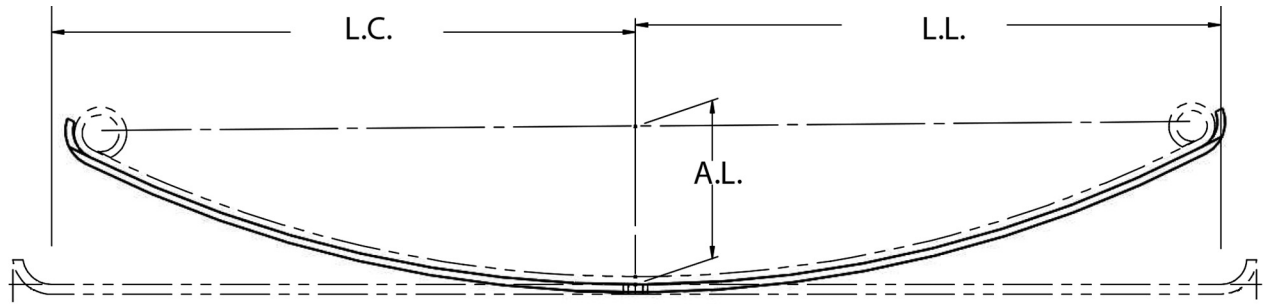

# SANDOVAL	# ORIGINAL	MODELO	ANCHO	ESPESOR	L./C.	L./L.	BRÍO	BUJE L./C	BUJE L./L
20025-NI2RD	-	Nissan Urban Mo. 02-05 / Trasera	2.362"	0.401"	23 7/8"	23 15/16"	6 7/16"	1 1/2"	1 1/4"

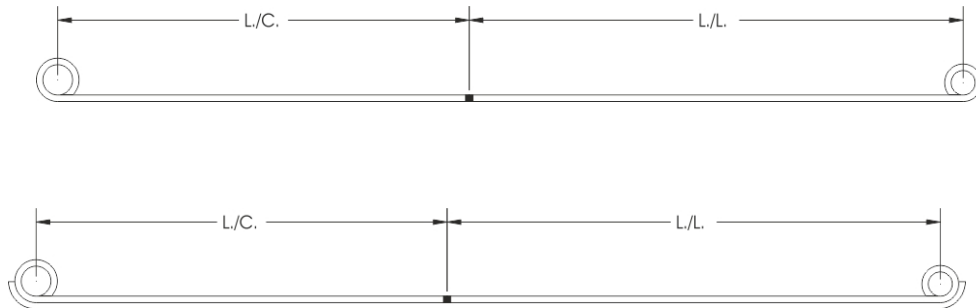

# SANDOVAL	# ORIGINAL	MODELO	ANCHO	ESPESOR	L./C.	L./L.	BRÍO	BUJE L./C	BUJE L./L
20822-NT1	-	Pick Up Urban Mod. 02-03 / Trasera	60 mm	9 mm	22 1/2"	27"	5 7/8"	1 5/8"	1 5/16"
20822-NT2RD		Refuerzo		9 mm	22 1/2"	27"			

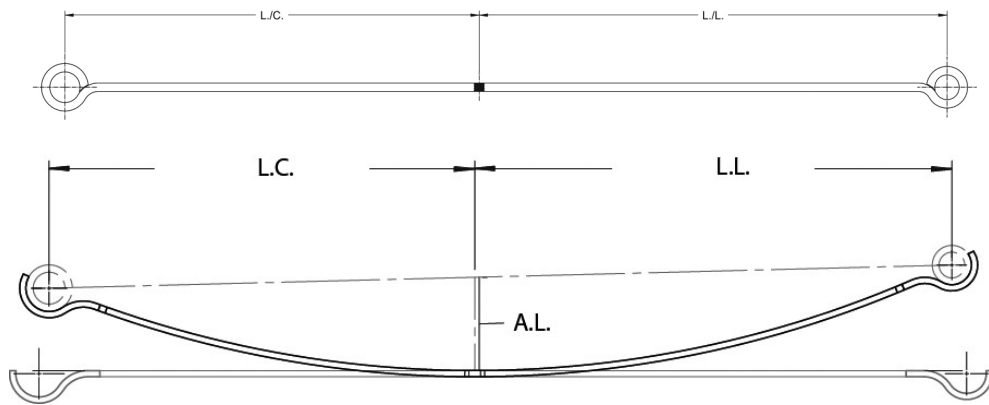

# SANDOVAL	# ORIGINAL	MODELO	ANCHO	ESPESOR	L./C.	L./L.	BRÍO	BUJE L./C	BUJE L./L
21725-NI	550204S100	Camioneta Frontier Mod. 08-09 / Trasera	60 mm	8 mm	22 1/4"	25 1/8"	4 3/4"		
21725-NI1				8 mm	22 1/4"	25 1/8"		1 5/8"	5/16"
21725-NI2RD				8 mm	22 1/4"	25 1/8"			

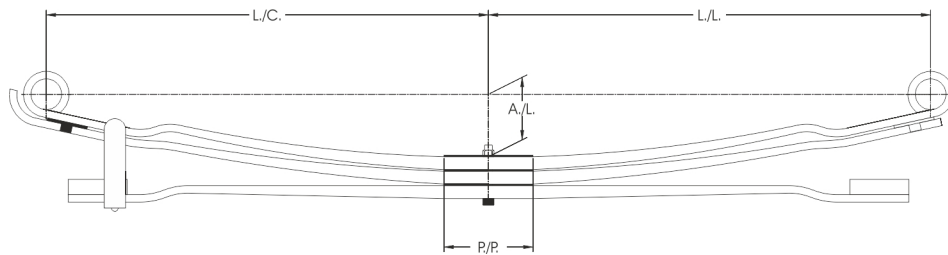

# SANDOVAL	# ORIGINAL	MODELO	ANCHO	ESPESOR	L./C.	L./L.	BRÍO	BUJE L./C	BUJE L./L
29025-NI		Cabstar Mod. 2008 / Trasera	2 1/2"	0.770"	25 1/4"	25 1/4"	3 1/2"		
29025-NI1				0.770"	25 1/4"	25 1/4"		.940	.940
29025-NI2				0.662"	25 1/4"	25 1/2"			
29025-NI3				0.662"	23 5/8"	23 5/8"			

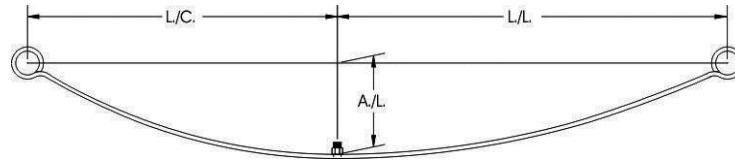

# SANDOVAL	# ORIGINAL	MODELO	ANCHO	ESPESOR	L./C.	L./L.	BRÍO	BUJE L./C	BUJE L./L
69-285	55020-EB005	Camioneta Frontier Mod. 2005-2011 / Trasera	60 mm	8 mm	26 3/8"	29 1/4"	5 5/8"		
69-285-1				8 mm	26 3/8"	29 1/4"		RB-109	MB-64133
69-285-2RD				8 mm	26 3/8"	29 1/4"			

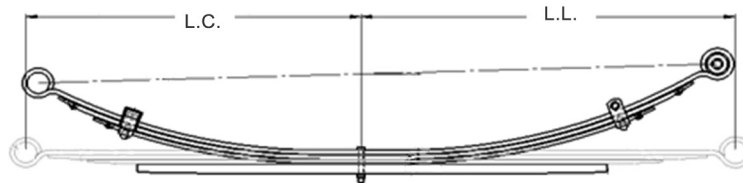

# SANDOVAL	# ORIGINAL	MODELO	ANCHO	ESPESOR	L./C.	L./L.	BRÍO	BUJE L./C	BUJE L./L
NI-0001	4KS0D-RPN 2575	NP300 2016	60 mm	8 mm	600 mm	670 mm			
NI-0001-1			60 mm	8 mm	600 mm	670 mm	145 mm	1.575	RB-282
NI-0001-2			60 mm	8 mm	560 mm	620 mm	145 mm		
NI-0001-3			60 mm	7 mm	490 mm	540 mm	145 mm		
NI-0001-4			60 mm	18 mm	400 mm	440 mm	Recto		

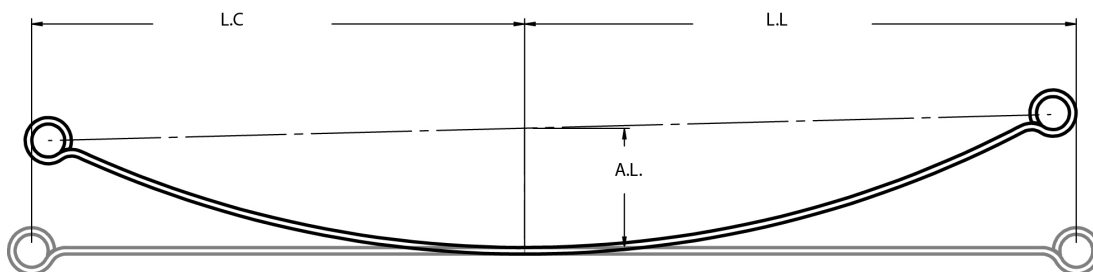

# SANDOVAL	# ORIGINAL	MODELO	ANCHO	ESPESOR	L./C.	L./L.	BRÍO	BUJE L./C	BUJE L./L
NI-0002-1	4K50D		60 mm	8 mm	23 9/16"	26 3/8"	5 11/16"	40 mm	40 mm

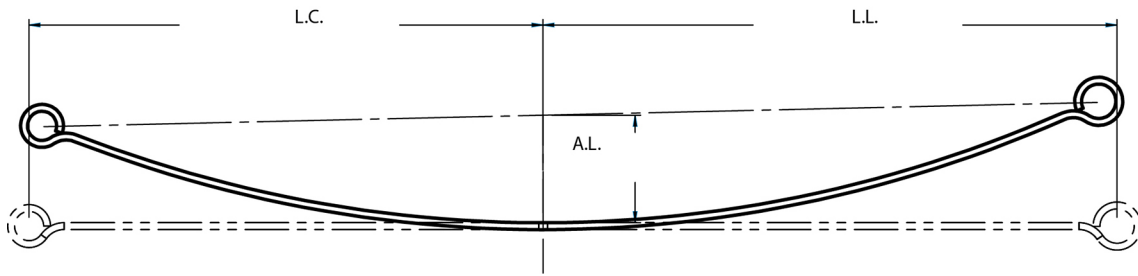

# SANDOVAL	# ORIGINAL	MODELO	ANCHO	ESPESOR	L./C.	L./L.	BRÍO	BUJE L./C	BUJE L./L
NI-0003-1			60 mm	8 mm	600 mm	671 mm	125 mm	34 mm	40 mm

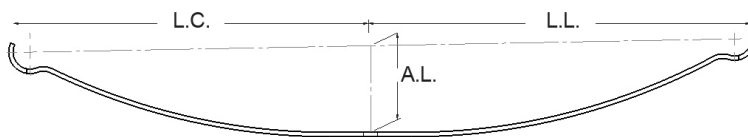

# SANDOVAL	# ORIGINAL	MODELO	ANCHO	ESPESOR	L./C.	L./L.	BRÍO	BUJE L./C	BUJE L./L
NI-0003-2RD		Refuerzo	60 mm	8 mm	603 mm	673 mm	125 mm	N/A	N/A

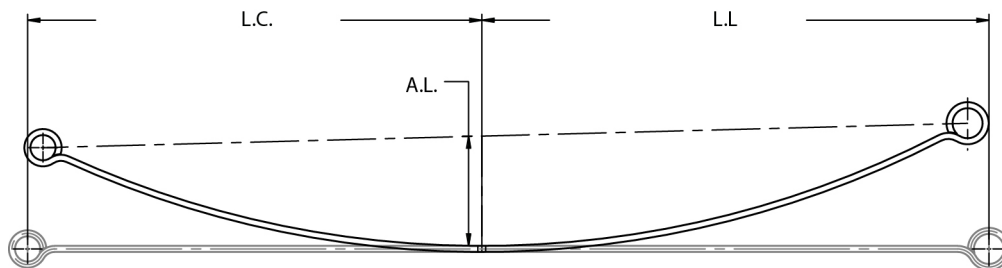

# SANDOVAL	# ORIGINAL	MODELO	ANCHO	ESPESOR	L./C.	L./L.	BRÍO	BUJE L./C	BUJE L./L
NI-0005-1		Estaquitas NP300 2017	60 mm	8 mm	600 mm	670 mm	145 mm	1.31"	1.56"

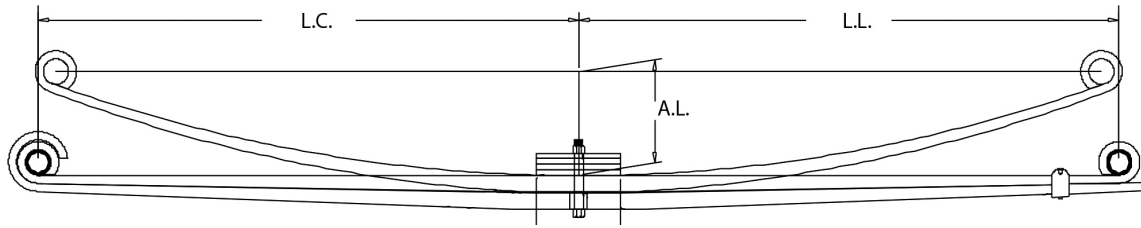

# SANDOVAL	# ORIGINAL	MODELO	ANCHO	ESPESOR	L./C.	L./L.	BRÍO	BUJE L./C	BUJE L./L
50032-PT	202584	M. Ranger Mod. 2002 / Delantera	4"	0.999"	32 1/8"	32 1/8"	6 1/8"		
50032-PT1				0.999"	32 1/8"	32 1/8"		RNK	RNK
50032-PT2				0.323"	32 1/8"	33 5/8"			
PAD				0.323"	2 1/2"	2 1/2"			
PAD				0.323"	2 1/2"	2 1/2"			
PAD				0.323"	2 1/2"	2 1/2"			
PAD				0.323"	2 1/2"	2 1/2"			

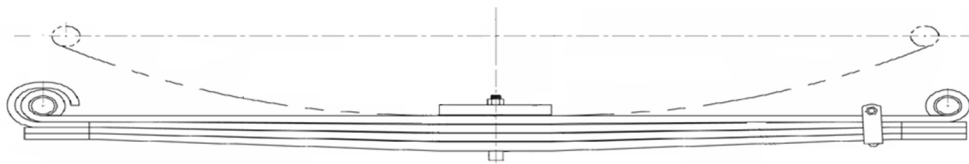

# SANDOVAL	# ORIGINAL	MODELO	ANCHO	ESPESOR	L./C.	L./L.	BRÍO	BUJE L./C	BUJE L./L
75-128	02-00774	-	3.543"	0.595"	24 3/8"	24 3/8"	5.44"		
PAD				0.394"	3"	3"		BM-RNI	BM-RNI
PAD				0.394"	3"	3"			
75-128-1				0.595"	24 3/8"	24 3/8"			
75-128-2				0.595"	24 3/8"	25 3/8"			
75-128-3				0.595"	25 3/8"	25 3/8"			
75-128-4				0.595"	25 3/8"	25 3/8"			

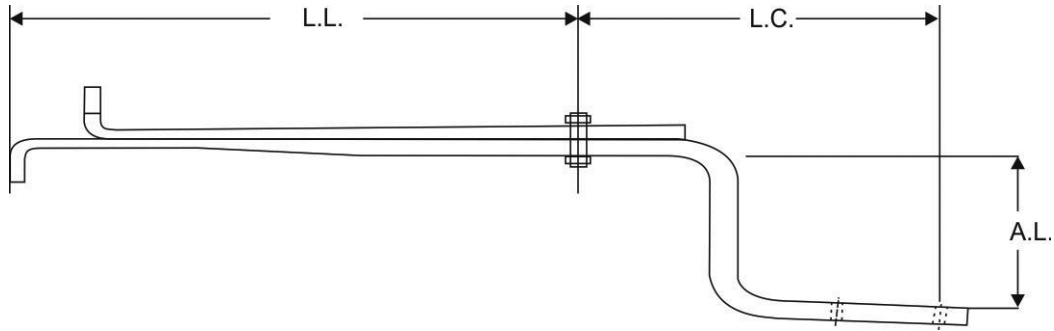

# SANDOVAL	# ORIGINAL	MODELO	ANCHO	ESPEJOR	L./C.	L./L.	BRÍO	BUJE L./C	BUJE L./L
75-163	03-07640	Suspension de Aire / Trasera	90 mm	38 mm	24"	5"	15 1/2"		
75-163-1				38 mm	24 "	5"			
75-163-2				38 mm	27 5/8"	18 7/8"			

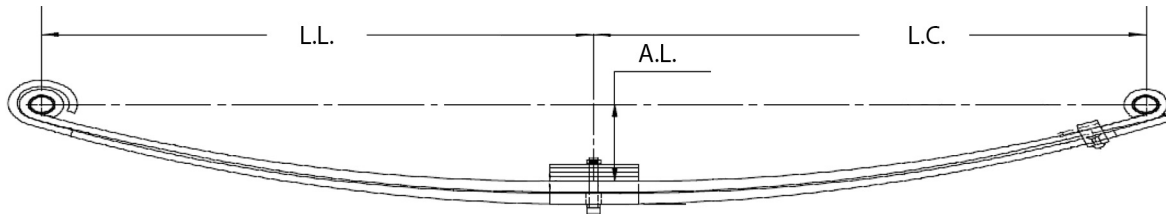

# SANDOVAL	# ORIGINAL	MODELO	ANCHO	ESPEJOR	L./C.	L./L.	BRÍO	BUJE L./C	BUJE L./L
75-210	02-02584	Delantera	4"	0.917"	32 1/8"	32 1/8"	6.13"		
75-210-1			4"	0.917"	32 1/8"	32 1/8"		BB-RNK	BB-RNK
75-210-2			4"	0.917"	32 1/8"	33 5/8"			

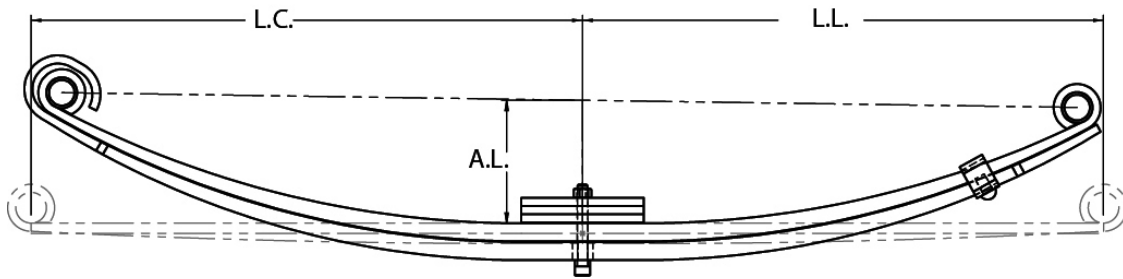

# SANDOVAL	# ORIGINAL	MODELO	ANCHO	ESPESOR	L./C.	L./L.	BRÍO	BUJE L./C	BUJE L./L
75-212	02-02177	Mod. 86-00 / Delantera	4"	0.999"	27"	25 1/2"	6"		
PAD				0.401"	3"	3"		BB-RNK	BB-RNK
PAD				0.401"	3"	3"			
PAD				0.401"	3"	3"			
75-212-1				0.999"	27"	25 1/2"			
75-212-2				0.999"	26 3/8"	53 3/8"			

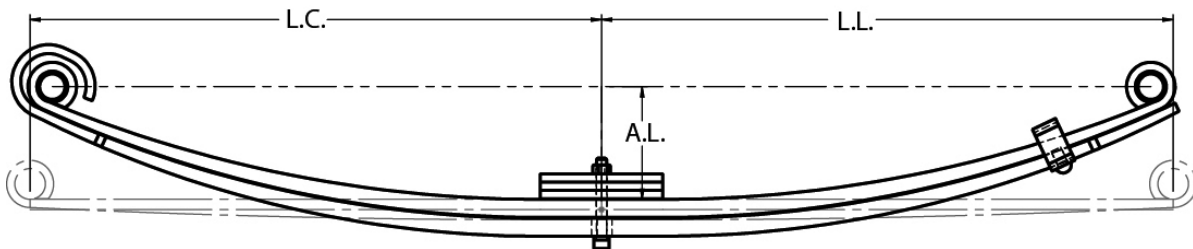

# SANDOVAL	# ORIGINAL	MODELO	ANCHO	ESPESOR	L./C.	L./L.	BRÍO	BUJE L./C	BUJE L./L
75-228	02-02177	Delantera	4"	0.866"	28"	28"	6"		
PAD				0.401"	3"	3"			
PAD				0.401"	3"	3"			
PAD				0.401"	3"	3"			
75-228-1				0.866"	28"	28"		BB-RNK	BB-RNK
75-228-2				0.866"	28"	29 1/8"			

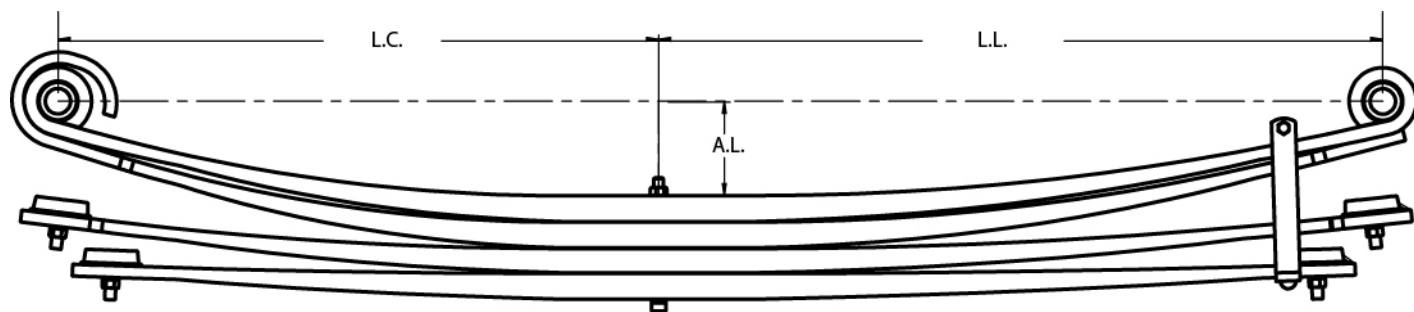

# SANDOVAL	# ORIGINAL	MODELO	ANCHO	ESPESOR	L./C.	L./L.	BRÍO	BUJE L./C	BUJE L./L
PT-0001	-	-	4"	1.310"	32"	38 1/4"	4 7/8"		
PT-0001-1				1.310"	32"	38 1/4"		TB-81	TB-81
PT-0001-2				1.310"	32"	39 1/4"			
PT-0001-3				1.260"	33 1/4"	39 1/4"			
PT-0001-4				1.310"	30 1/2"	36 1/4"			

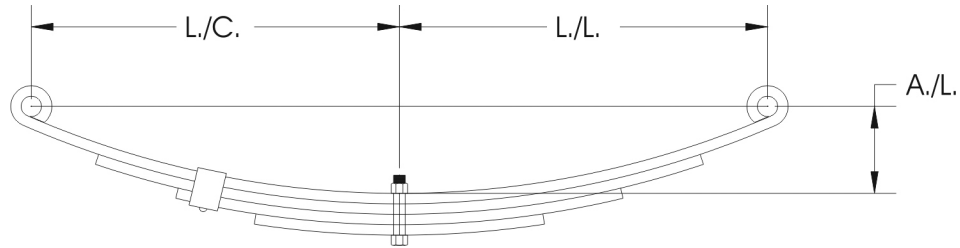

# SANDOVAL	# ORIGINAL	MODELO	ANCHO	ESPESOR	L./C.	L./L.	BRÍO	BUJE L./C	BUJE L./L
17014-E	-	Remolque, Adaptacion Especial Mod. 86-00	1 3/4"	0.360"	14"	14"	3 1/2"		
17014-E1				0.360"	14"	14"		1736003	1736003
17014-E2				0.360"	13"	13"			
17014-E3				0.360"	11"	11"			
17014-E4				0.360"	8"	8"			

Remolque

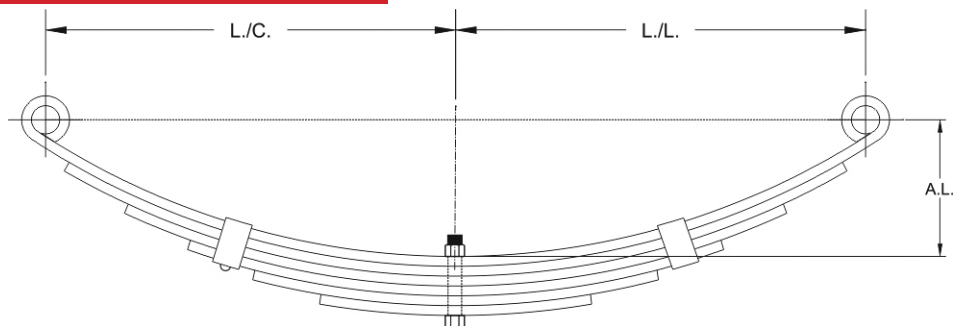

# SANDOVAL	# ORIGINAL	MODELO	ANCHO	ESPESOR	L./C.	L./L.	BRÍO	BUJE L./C	BUJE L./L
23016	MTR901	Remolque Agricola QTR 400 lbs Mod. 2002 / Trasera	2 1/2"	0.360"	16 1/4"	16 1/4"	5"		
23016-1				0.360"	16 1/4"	16 1/4"	5"	Metálico esp. 1 1/32"	Metálico esp. 1 1/32"
23016-2				0.360"	15"	15"	5"		
23016-3				0.360"	12 1/2"	12 1/2"	5"		
23016-4				0.360"	10"	10"	5"		
23016-5				0.360"	7 1/2"	7 1/2"	5"		
23016-6				0.360"	5"	5"	5"		
23016-M1				0.360"	16 1/4"	16 1/4"	6"		
23016-M2				0.360"	15"	15"	6"		
23016-M3				0.360"	12 1/2"	12 1/2"	6"		
23016-M4				0.360"	10"	10"	6"		
23016-M5				0.360"	7 1/2"	7 1/2"	6"		
23016-M6				0.360"	5"	5"	6"		

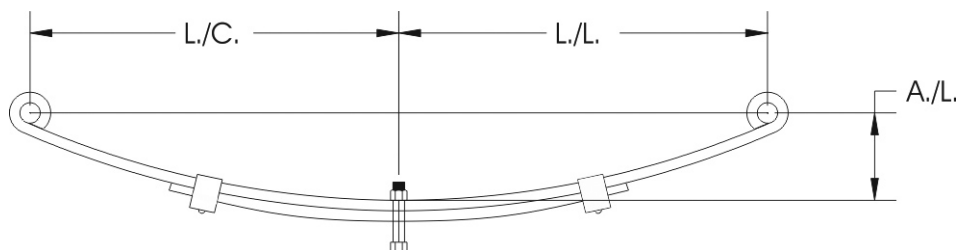

# SANDOVAL	# ORIGINAL	MODELO	ANCHO	ESPESOR	L./C.	L./L.	BRÍO	BUJE L./C	BUJE L./L
20816-E	-	Remolque	2 1/4"	0.360"	16"	16"	4"		
20816-E1				0.360"	16"	16"		BB-JFD	BB-JFD
20816-E2				0.360"	10 1/2"	10 1/2"			

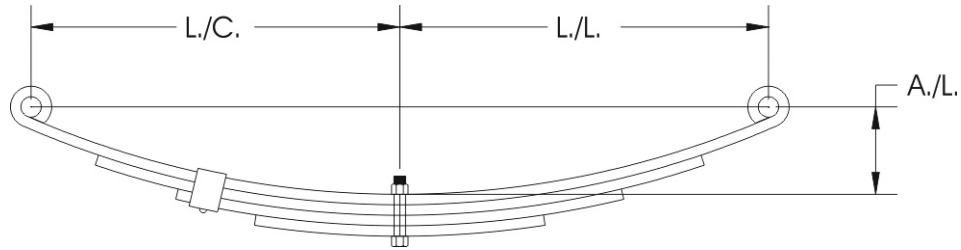

# SANDOVAL	# ORIGINAL	MODELO	ANCHO	ESPESOR	L./C.	L./L.	BRÍO	BUJE L./C.	BUJE L./L.
SW4	4342-24	Remolque 2400 LBS Mod. 86-00 / Trasera	1 3/4"	0.360"	13 3/16"	13 3/16"	3"		
SW4-1				0.360"	13 3/16"	13 3/16"		1736003	1736003
SW4-2				0.360"	10 5/8"	10 5/8"			
SW4-2R				0.360"	13 3/16"	13 3/16"			
SW4-3				0.360"	7 3/4"	7 3/4"			
SW4-4				0.360"	5"	5"			

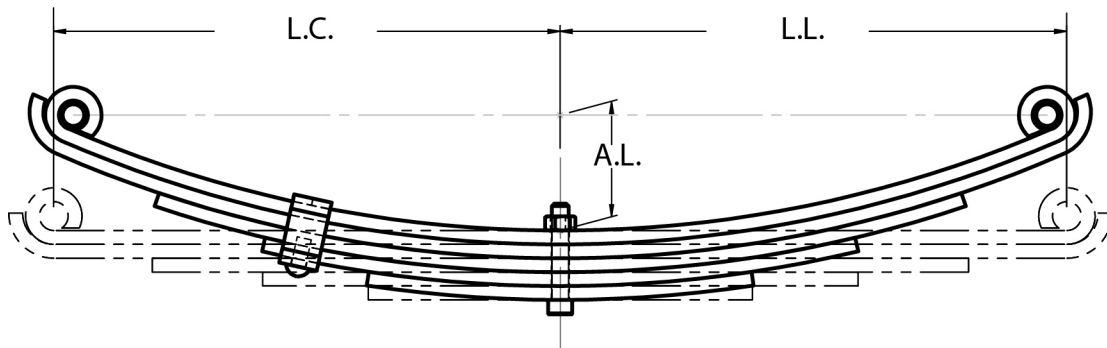

# SANDOVAL	# ORIGINAL	MODELO	ANCHO	ESPESOR	L./C.	L./L.	BRÍO	BUJE L./C.	BUJE L./L.
SW4-C	-	Remolque	1.750"	0.360"	13 3/16"	13 3/16"	3"		
SW4-C1				0.360"	13 3/16"	13 3/16"		1736003	1736003
SW4-C2				0.360"	13 3/16"	13 3/16"			
SW4-C3				0.360"	10 5/8"	21 1/4"			
SW4-C4				0.360"	7 3/4"	15 1/2"			
SW4-C5				0.360"	5"	10"			

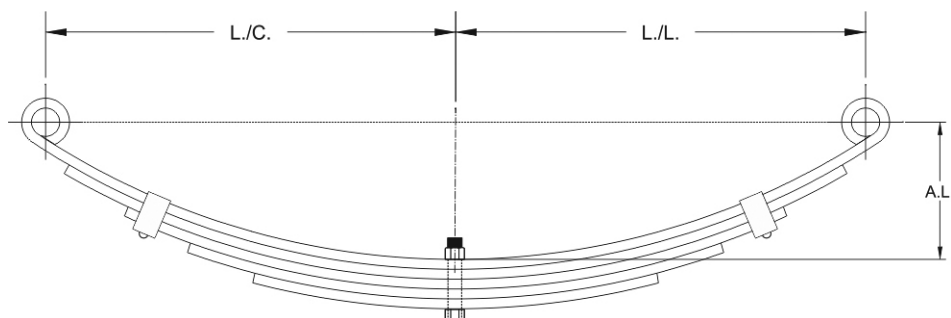

# SANDOVAL	# ORIGINAL	MODELO	ANCHO	ESPESOR	L./C.	L./L.	BRÍO	BUJE L./C	BUJE L./L
SW5	4342-29	Remolque Mod. 86-00 / Trasera	1 3/4"	0.360"	13 3/16"	13 3/16"	3"		
SW5-1				0.360"	13 3/16"	13 3/16"		1736003	1736003
SW5-2				0.360"	11 1/8"	11 1/8"			
SW5-3				0.360"	8 7/8"	8 7/8"			
SW5-4				0.360"	6 5/8"	6 5/8"			
SW5-5				0.360"	4 3/8"	4 3/8"			

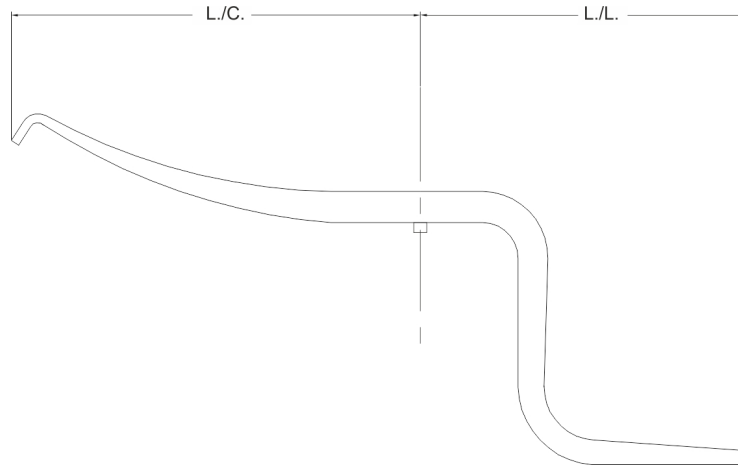

# SANDOVAL	# ORIGINAL	MODELO	ANCHO	ESPESOR	L./C.	L./L.	BRÍO	BUJE L./C	BUJE L./L
83-167	15676-01	Susp.Reyco 102AR, 104AR	3"	1.750"	575.50	466.70		N/A	N/A

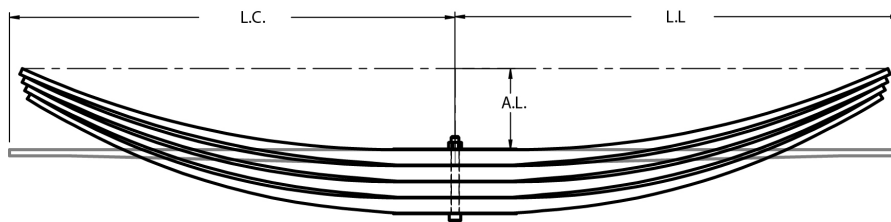

# SANDOVAL	# ORIGINAL	MODELO	ANCHO	ESPESOR	L./C.	L./L.	BRÍO	BUJE L./C	BUJE L./L
83-273	HP48210-1500	Trasera	3"	0.938"	29"	29"	5 1/4"	N/A	N/A
				0.938"	29"	29"			
				0.938"	29"	29"			
				0.938"	29"	29"			

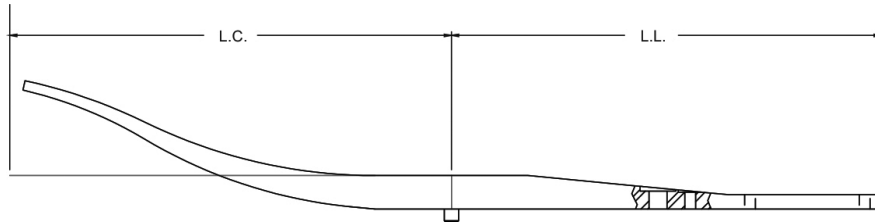

# SANDOVAL	# ORIGINAL	MODELO	ANCHO	ESPEJOR	L./C.	L./L.	BRÍO	BUJE L./C	BUJE L./L
TRA-074	1991301	Susp.Reyco T-300 Mod. 00-01 / Trasera	3"	1.750"	23 1/8"	22 1/2"	6 11/16"		
TRA-074R				1.875"	23 1/8"	22 1/2"			

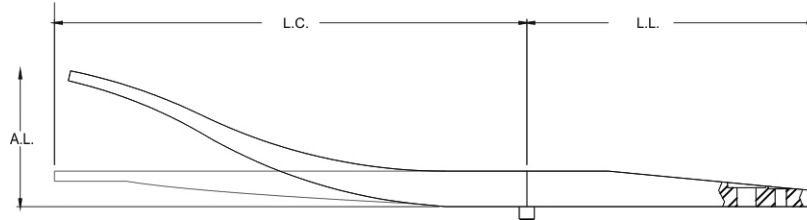

# SANDOVAL	# ORIGINAL	MODELO	ANCHO	ESPESOR	L./C.	L./L.	BRÍO	BUJE L./C	BUJE L./L
TRA-075	1991401	86AR Mod. 00-05 / Trasera	3"	1.750"	23 1/4"	14 3/16"	6 11/16"		
TRA-075R				1.875"	23 1/4"	14 3/16"			

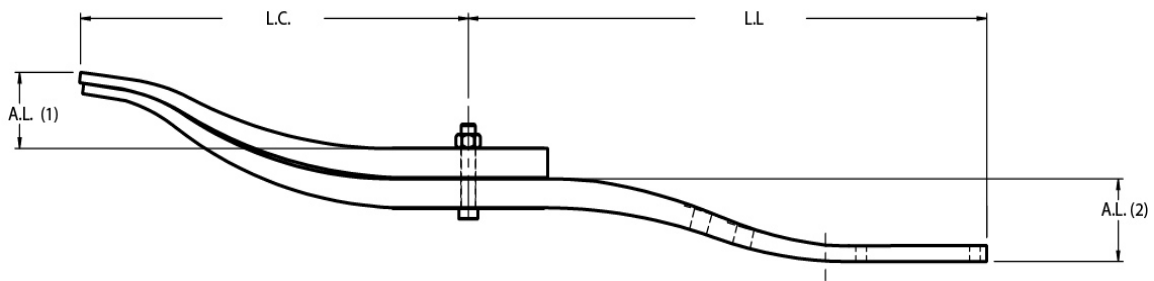

# SANDOVAL	# ORIGINAL	MODELO	ANCHO	ESPESOR	L./C.	L./L.	BRÍO	BUJE L./C	BUJE L./L
TRA-3387	20741-01	2LF (izq.)	3"	1.375"	20 3/8"	27 5/8"	3 5/8" 3 7/8"	N/A	N/A
TRA-33871			3"	1.375"	20 3/8"	4 3/16"			
TRA-33872			3"	1.375"	20 3/8"	27 5/8"			

Tirante

Tirante

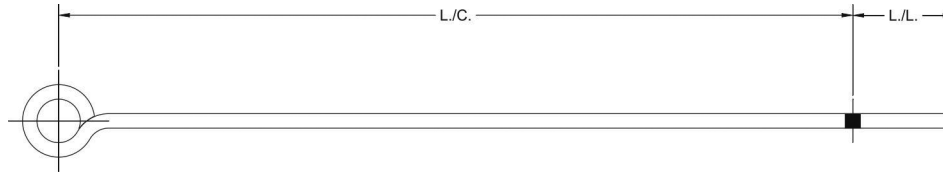

# SANDOVAL	APLICACION	MODELO	ANCHO	ESPESOR	L/C.	L./L.	BRÍO	BUJE
37527-T	Tirante Especial		3"	0.447"	27"	4 3/4"	-	1 13/16"
37127-T	Hoja Tirante	International Mod. 00-05		0.447"	27"	3 3/4"	1 13/16"	RB-164
37127-TR	2da Tirante	International Mod. 00-05	3"	0.447"	27"	3 3/4"	1 13/16"	N/A
36122-TV	Hoja Tirante	Volvo Mod. 1995	3"	0.625"	22 7/8"	4"	Recto	2 17/32"
36122-TVR	Refuerzo para Tirante	Volvo Mod. 1995	3"	0.625"	22 7/8"	4"	Recto	N/A
34030-B12	Hoja Tirante	Dodge Mod. 80-83	3"	0.447"	25 1/2"	3 1/2"	2"	RB-116
34030-B12R	Refuerzo para Tirante	Dodge Mod. 80-83	3"	0.447"	25 1/2"	3 1/2"	2"	N/A
32533-T	Tirante Especial	-	3"	0.499"	33"	3 1/2"	1 3/4"	1 5/8"
32533-TDR	Refuerzo para Tirante Especial	-	3"	0.499"	33"	3 1/2"	2 7/8"	N/A
32534-TR	Hoja Tirante 2A	Mercedes Benz	3"	0.499"	34 1/2"	3"	2"	2 5/8"
32534-TDR	Refuerzo para Tirante Especial	Dina	3"	0.499"	35"	3 1/2"	2 1/2"	N/A
32534-TD	Tirante Especial	Freightliner	3"	0.499"	34"	3 1/2"	2 1/2"	RNG
32534-T	Hoja Tirante	Mercedes Benz	3"	0.499"	34 1/2"	3"	2"	RNG
32442-TR	2da Tirante	Freightliner	3"	0.499"	42"	N/A	1 3/4"	N/A
32235-TFR	2da para Tirante	Freightliner	3"	0.499"	35"	6"	4 1/2"	N/A
32225-LR	Refuerzo para Tirante	-	3"	0.499"	25 3/4"	3 3/4"	2 1/4"	N/A
32136-T	Tirante Especial	Dina	3"	0.499"	36"	3 1/2"	2"	RB 2 1/2"
32135-TF	Hoja Tirante	Freightliner	3"	0.499"	35"	6"	4 1/2"	RB 2 1/2"
32125-LR	Tirante Especial	2003	3"	0.499"	25 3/4"	3 3/4"	1 3/4"	1 5/8"
32038-15R	Refuerzo para Tirante	Dina Mod. 65-85	3"	0.499"	33"	3 1/2"	5 1/2"	2 3/4"
32038-14	Hoja Tirante	Dina Mod. 65-85	3"	0.499"	33"	3 1/2"	5 1/2"	RNG
48523-F	Tirante Especial / Mano chango	Freightliner Mod. 80-89	4"	0.662"	22 1/2"	4 1/2"	Recto	N/A

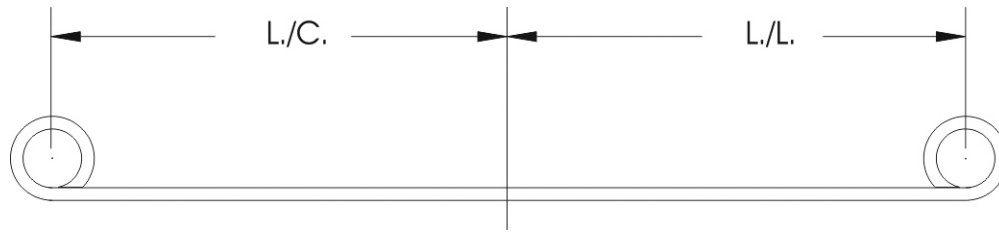

# SANDOVAL	# ORIGINAL	MODELO	ANCHO	ESPESOR	L./C.	L./L.	BRÍO	BUJE L./C	BUJE L./L
19822-B	-	Hilux Estaquitas Mod Mod. 95-96 / Trasera	2 1/4"	0.291"	22"	28 1/2"	7"	1 9/16"	1 3/16"

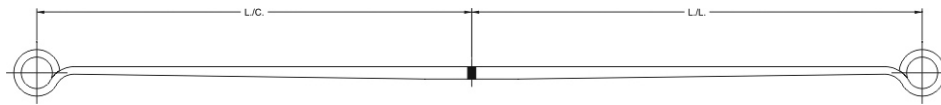

# SANDOVAL	# ORIGINAL	MODELO	ANCHO	ESPESOR	L./C.	L./L.	BRÍO	BUJE L./C	BUJE L./L
19822-T	-	Tacoma Mod. 95- 96 / Trasera	60 mm	8 mm	22 1/4"	24 3/4"	5 3/8"	1 9/16"	1 1/4"



# SANDOVAL	# ORIGINAL	MODELO	ANCHO	ESPESOR	L./C.	L./L.	BRÍO	BUJE L./C	BUJE L./L
19822-TY	-	Tacoma Mod. 1997 / Trasera	60 mm	8 mm	22 1/2"	28 5/8"	5"		
19822-TY1				8 mm	22 1/2"	28 5/8"	5"	RB-192	RB-192
19822-TY2				8 mm	22 1/2"	25 1/8"	5"		
19822-TY2RD				8 mm	22 1/2"	28 5/8"	5 1/2"		
19822-TY3				6 mm	17"	21 3/8"	5"		
19822-TY4				16 mm	13"	17"	5"		

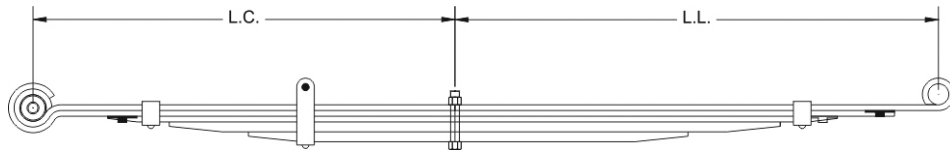

# SANDOVAL	# ORIGINAL	MODELO	ANCHO	ESPESOR	L./C.	L./L.	BRÍO	BUJE L./C	BUJE L./L
20024-TY	L166DOS	Hilux Estaquitas Mod. 2006 / Trasera	2 1/4"	0.323"	24"	27"	5 1/8" 2da Recto		
20024-TY1				0.323"	24"	27"		RB-294R	30 mm
20024-TY2				0.323"	24"	25"			
20024-TY2RD				0.323"	24"	27 1/2"			
20024-TY3				0.323"	19 3/4"	21 3/4"			
20024-TY4				0.558"	16 1/4"	18 1/2"			
20024-TY5				0.558"	11 3/4"	13 1/4"			

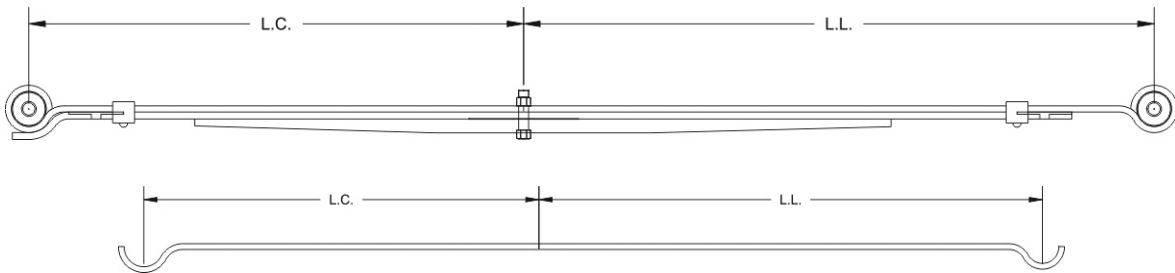

# SANDOVAL	# ORIGINAL	MODELO	ANCHO	ESPESOR	L./C.	L./L.	BRÍO	BUJE L./C	BUJE L./L
20722-TY	4821004051	Tacoma / Trasera	60 mm	7 mm	22 9/16"	28 3/4"	5 9/16"		
20722-TY1				7 mm	22 9/16"	28 3/4"		RB-192	30 mm
20722-TY2				8 mm	22 9/16"	25"			
20722-TY2RD				8 mm	22 9/16"	28 3/4"			
20722-TY3				16 mm	15"	16 3/4"			

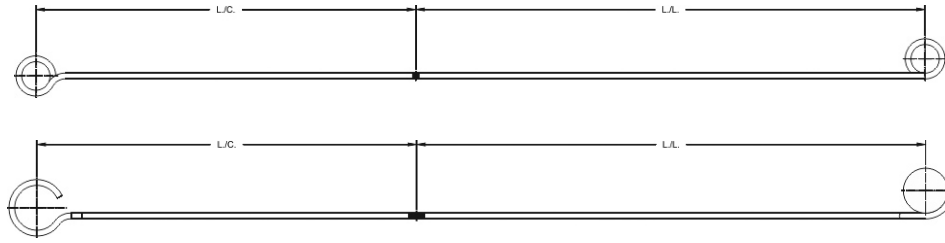

# SANDOVAL	# ORIGINAL	MODELO	ANCHO	ESPESOR	L./C.	L./L.	BRÍO	BUJE L./C	BUJE L./L
21623-TY	4821004180A	Tacoma Mod. 98-04 / Trasera	60 mm	9 mm	23 1/2"	31 1/2"	4 1/2"		
21623-TY1				9 mm	23 1/2"	31 1/2"		1 3/4"	1 3/4"
21623-TY2				9 mm	23 1/2"	31 1/2"			

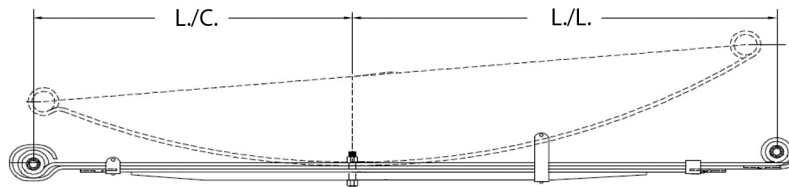

# SANDOVAL	# ORIGINAL	MODELO	ANCHO	ESPESOR	L./C.	L./L.	BRÍO	BUJE L./C	BUJE L./L
21722	4821035810	Hilux Americana Mod. 94-2000 / Trasera	60 mm	8 mm	22"	29 1/4"	6 1/2"		
21722-1				8 mm	22"	29 1/4"		RB-192R	RB-192R
21722-2				8 mm	22"	29 1/4"			
21722-3				8 mm	18 3/4"	25 3/4"			
21722-4				15 mm	15 1/4"	20 1/4"			

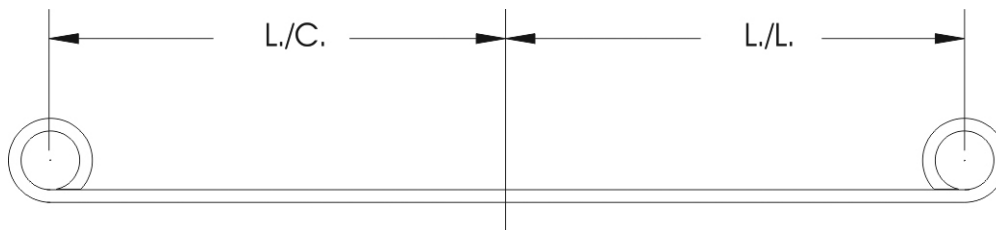

# SANDOVAL	# ORIGINAL	MODELO	ANCHO	ESPESOR	L./C.	L./L.	BRÍO	BUJE L./C	BUJE L./L
21722-TY	4811035030	Hilux Mod. 93 / Delantera	60 mm	8 mm	22 1/2"	22 1/2"	4"	30 mm	30 mm

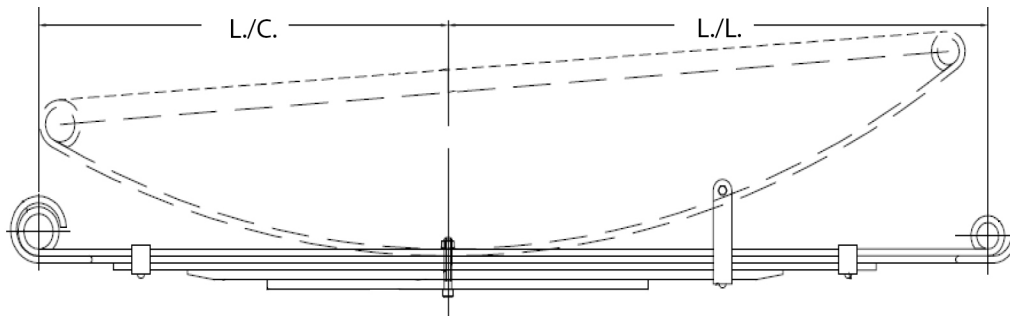

# SANDOVAL	# ORIGINAL	MODELO	ANCHO	ESPELOR	L./C.	L./L.	BRÍO	BUJE L./C.	BUJE L./L.
21729-TY	-	HILUX LN 166 Tra-sera Mod. 98-02	60 mm	8	22"	29"	6 1/2"		
21729-TY1				8	22"	29"		40mm	30mm
21729-TY2				8	22"	29"			
21729-TY3				14	18"	23"			
21729-TY4				14	14	18 1/4"			
21729-TY5					9 3/4"	10 3/4"			

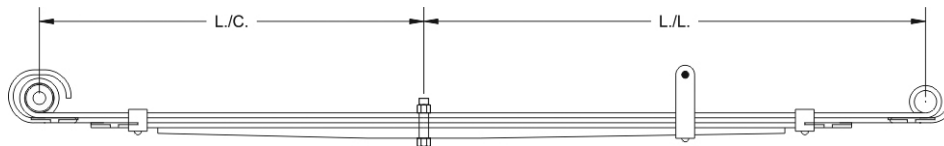

# SANDOVAL	# ORIGINAL	MODELO	ANCHO	ESPELOR	L./C.	L./L.	BRÍO	BUJE L./C.	BUJE L./L.
27620-TY	4821035460	Pick Up Mod. 85-95 / Trasera	2 1/4"	0.262"	20 1/2"	26 3/4"	6 11/16"		
27620-TY1				0.262"	20 1/2"	26 3/4"		RB-192	30mm
27620-TY2				0.262"	20 1/2"	26 3/4"			
27620-TY3				0.262"	17 3/4"	22 13/16"			
27620-TY4				0.558"	14 1/4"	19 1/4"			

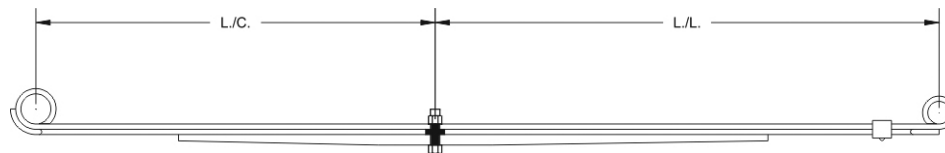

# SANDOVAL	# ORIGINAL	MODELO	ANCHO	ESPESOR	L./C.	L./L.	BRÍO	BUJE L./C	BUJE L./L
27621-TY	4821035660	Hilux Americana / Trasera	60 mm	8 mm	21"	26 1/2"	4 3/4"		
27621-TY1				8 mm	21"	26 1/2"		40 mm	30 mm
27621-TY2				8 mm	21"	26 1/2"			
27621-TY3				14 mm	13 1/2"	17 1/2"			

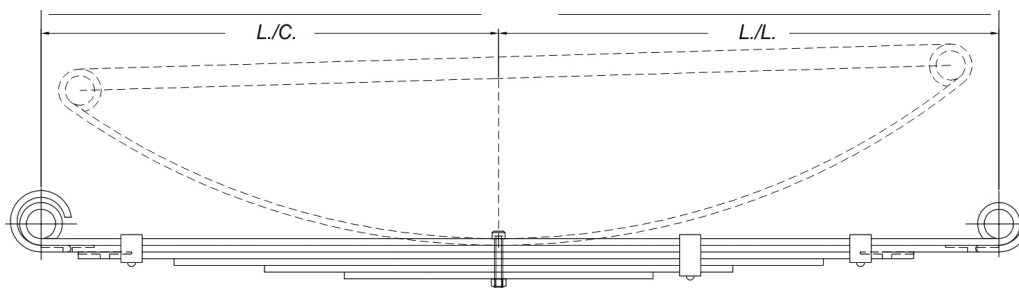

# SANDOVAL	# ORIGINAL	MODELO	ANCHO	ESPESOR	L./C.	L./L.	BRÍO	BUJE L./C	BUJE L./L
27921-TY	-	Land Crusier Mod. 87-96 / Delantea	70 mm	7 mm	21 1/2"	23 1/2"	7 1/8"		
27921-TY1				7 mm	21 1/2"	23 1/2"		35 mm	35 mm
27921-TY2				7 mm	21 1/2"	23 1/2"			
27921-TY3				7 mm	19 3/4"	19 1/25"			
27921-TY4				7 mm	15 1/4"	15 1/4"			
27921-TY5				7 mm	11"	11"			
27921-TY6				7 mm	7 1/4"	7 1/4"			

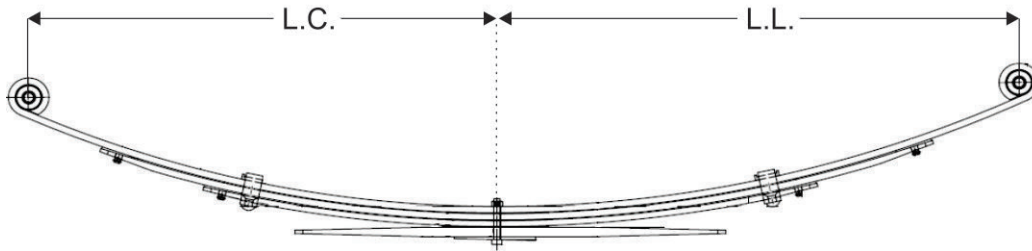

# SANDOVAL	# ORIGINAL	MODELO	ANCHO	ESPESOR	L./C.	L./L.	BRÍO	BUJE L./C	BUJE L./L
90-287	48210-0D080	Trucks	60 mm	10 mm	725 mm	810 mm			
90-287-1				10 mm	725 mm	810 mm	181 mm	RB-294R	RB-294R
90-287-2				10 mm	600 mm	660 mm	5 mm		
90-287-2RD				10 mm	375 mm	375 mm			
90-287-3				9 mm	440 mm	480 mm			
90-287-4				15 mm	300 mm	340 mm			
CUÑA				6 mm	64	57 1/2			

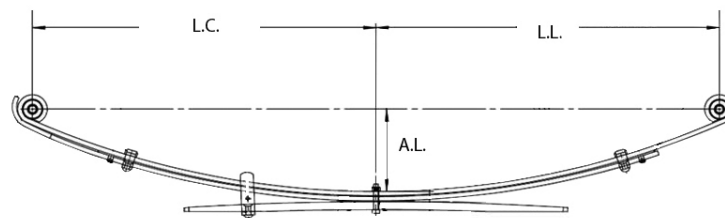

# SANDOVAL	# ORIGINAL	MODELO	ANCHO	ESPESOR	L./C.	L./L.	BRÍO	BUJE L./C	BUJE L./L
90-297	48210-04550	Trucks / Trasera	60 mm	9 mm	700 mm	700 mm	159 mm		
90-297-1				9 mm	700 mm	700 mm	159 mm	RB-294R	RB-294R
90-297-2				9 mm	700 mm	560 mm	159 mm		
90-297-3				16 mm	375 mm	375 mm	12 mm		

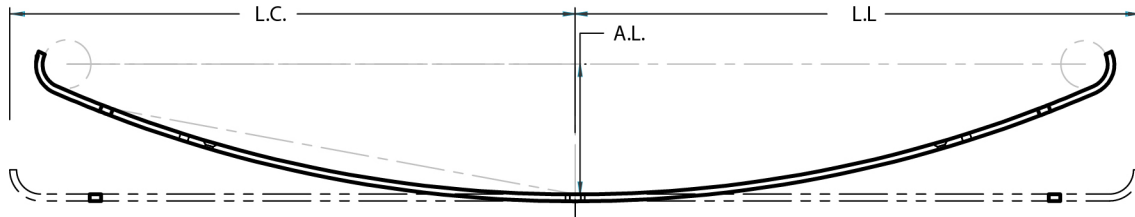

# SANDOVAL	# ORIGINAL	MODELO	ANCHO	ESPESOR	L./C.	L./L.	BRÍO	BUJE L./C	BUJE L./L
90-297-2RD	48220-04550	TRUCKS RIGHT SIDE	60 mm	9 mm	700 mm	700 mm	171	N/A	N/A

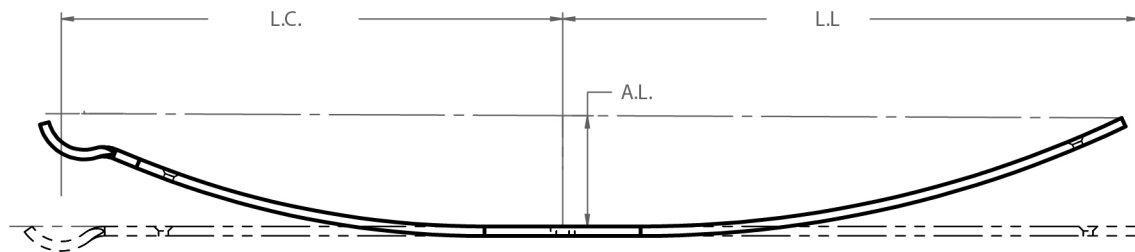

# SANDOVAL	# ORIGINAL	MODELO	ANCHO	ESPESOR	L./C.	L./L.	BRÍO	BUJE L./C	BUJE L./L
TY-0002-2	-	Hiace	60 mm	10 mm	20 7/8"	24"	4 1/2"	N/A	N/A

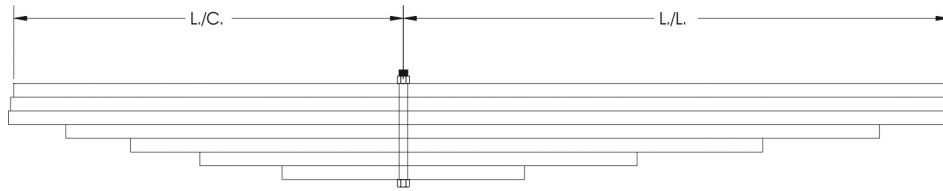

# SANDOVAL	# ORIGINAL	MODELO	ANCHO	ESPESOR	L./C.	L./L.	BRÍO	BUJE L./C	BUJE L./L
49024	95-170	Gondola Mod. 90-94 / Trasera	4"	0.788"	22 1/2"	31 1/2"	3 3/4"		
49024-1				0.788"	22 1/2"	31 1/2"			
49024-2				0.788"	22 11/16"	31 11/16"			
49024-3				0.788"	22 13/16"	31 13/16"			
49024-4				0.788"	19 1/2"	27 1/2"			
49024-5				0.788"	15 3/4"	20 3/4"			
49024-6				0.788"	11 3/4"	13 1/2"			
49024-7				0.788"	7"	7"			

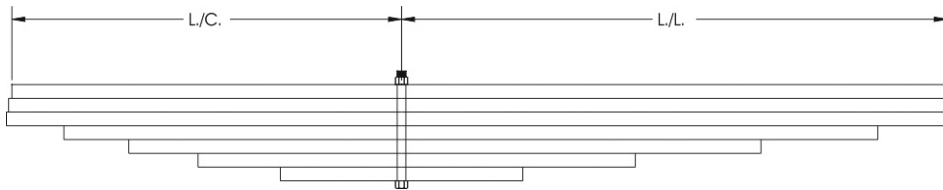

# SANDOVAL	# ORIGINAL	MODELO	ANCHO	ESPESOR	L./C.	L./L.	BRÍO	BUJE L./C	BUJE L./L
49024-A	95-180	Gondola Mod. 90-94 / Trasera	4"	0.788"	24 1/2"	29 1/2"	3 3/4"		
49024-A1				0.788"	24 1/2"	29 1/2"			
49024-A2				0.788"	24 11/16"	29 11/16"			
49024-A3				0.788"	24 13/16"	29 13/16"			
49024-A4				0.788"	19 1/2"	27 1/2"			
49024-A5				0.788"	15 3/4"	20 3/4"			
49024-A6				0.788"	11 3/4"	13 1/2"			
49024-A7				0.788"	7"	7"			

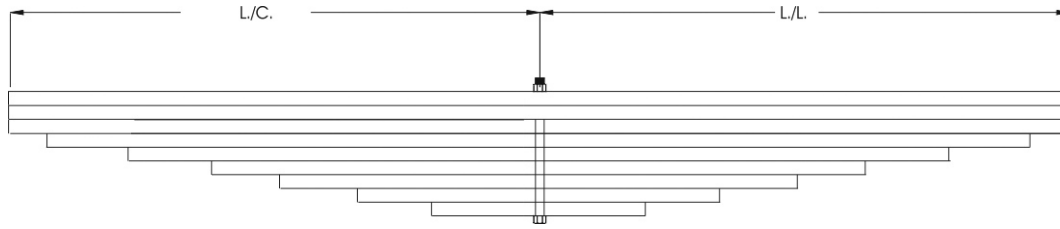

# SANDOVAL	# ORIGINAL	MODELO	ANCHO	ESPESOR	L./C.	L./L.	BRÍO	BUJE L./C	BUJE L./L
49024-B	95-255	Gondola Mod. 90-94 / Trasera	4"	0.788"	29 1/2"	29 1/2"	3 3/4"		
49024-B1				0.788"	29 1/2"	29 1/2"			
49024-B2				0.788"	29 11/16"	29 11/16"			
49024-B3				0.788"	29 13/16"	29 13/16"			
49024-B4				0.788"	24"	24"			
49024-B5				0.788"	21 1/8"	21 1/8"			
49024-B6				0.788"	18 1/2"	18 1/2"			
49024-B7				0.788"	15 3/4"	15 3/4"			
49024-B8				0.788"	13 3/8"	13 3/8"			
49024-B9				0.788"	10"	10"			

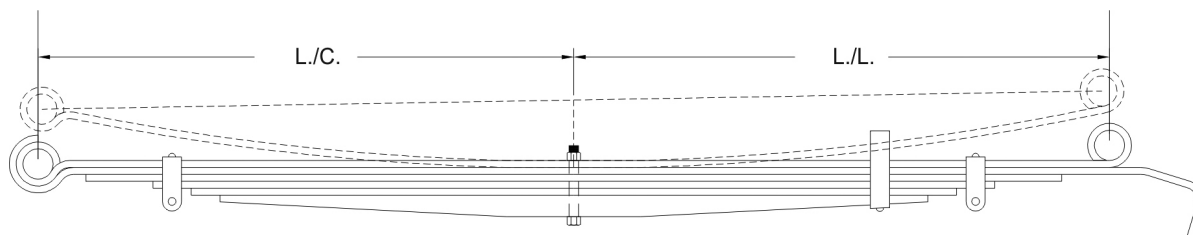

# SANDOVAL	# ORIGINAL	MODELO	ANCHO	ESPESOR	L./C.	L./L.	BRÍO	BUJE L./C	BUJE L./L
33028-VW	2REE5110099A	Volks Bus 8-150 Mod. 05-07 / Trasera	3"	0.360"	28"	28"	3"		
33028-VW1				0.360"	28"	28"		RB-204	RB-204
33028-VW2				0.360"	28"	32"			
33028-VW3				0.360"	25 1/2"	25 1/2"			
33028-VW4				0.360"	22"	22"			
33028-VW5				0.360"	20"	20"			
33028-VW6				0.938"	18 1/2"	18 1/2"			

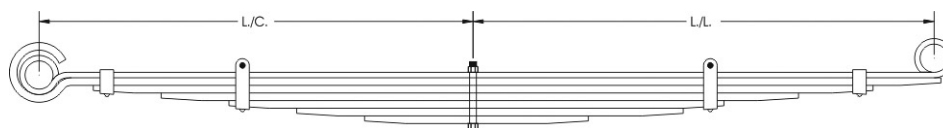

# SANDOVAL	# ORIGINAL	MODELO	ANCHO	ESPESOR	L./C.	L./L.	BRÍO	BUJE L./C	BUJE L./L
34032-VW	-	VW15-190 Mod. 05-06 / Delantera	3"	0.401"	32"	34"	3 1/2"		
34032-VW1				0.401"	32"	34"		8150	8150
34032-VW2				0.401"	32"	34 1/2"			
34032-VW3				0.558"	28 "	29 1/2"			
34032-VW4				0.558"	23"	24"			
34032-VW5				0.558"	18"	15 1/2"			
34032-VW6				0.558"	13"	13 1/2"			
34032-VW7				0.558"	8"	8 1/2"			

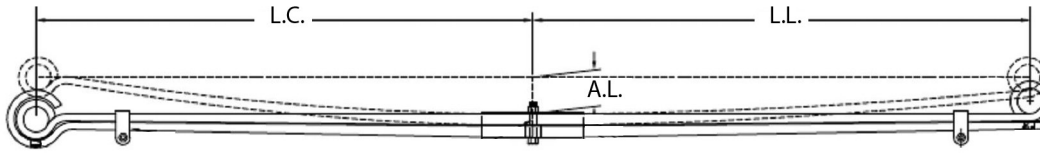

# SANDOVAL	# ORIGINAL	MODELO	ANCHO	ESPESOR	L./C.	L./L.	BRÍO	BUJE L./C	BUJE L./L
39034-VW	2R0411102C	Volks Bus 8-150E Mod. 05-07 / Delantera	3"	0.788"	34 1/4"	34 1/4"	2 1/2"		
39034-VW1				0.788"	34 1/4"	34 1/4"		45 mm	45 mm
39034-VW2				0.788"	34 1/4"	35 1/2"			
39034-VW2R				0.788"	35 1/2"	35 1/2"			

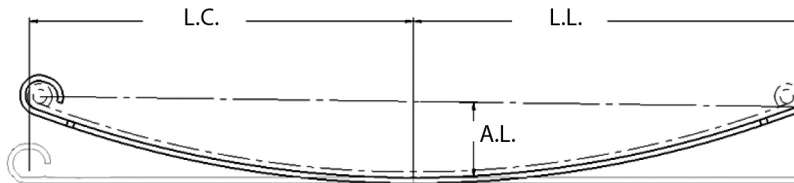
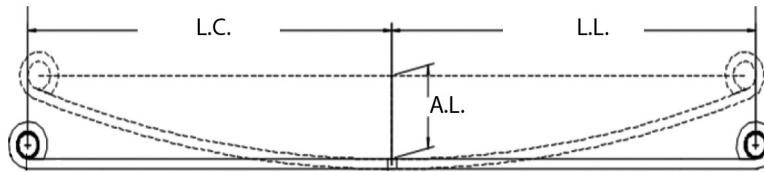

# SANDOVAL	# ORIGINAL	MODELO	ANCHO	ESPESOR	L./C.	L./L.	BRÍO	BUJE L./C	BUJE L./L
42035-VW	VWT355	VW 17-210 EOD Mod. 2005 / Delantera	4"	0.499"	35 1/2"	35 1/2"	6 5/8"		
42035-VW1			4"	0.499"	35 1/2"	35 1/2"		NJK	NJK
42035-VW2			4"	0.499"	35 3/4"	36 1/4"	6 11/16"		



# SANDOVAL	# ORIGINAL	MODELO	ANCHO	ESPESOR	L./C.	L./L.	BRÍO	BUJE L.C	BUJE L.L
VW-0001-T	-	Tirante Urbano Trasero Mod. 2009	3"	0.558"	18 3/16"	38 1/2"	2 1/8"		1 1/2"

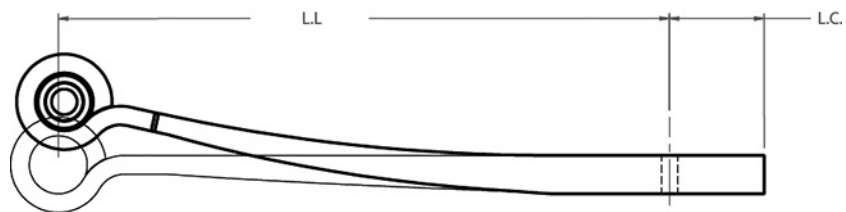

# SANDOVAL	# ORIGINAL	MODELO	ANCHO	ESPESOR	L./C.	L./L.	BRÍO	BUJE L.C	BUJE L.L
VW-0002-1	-	Autobus 17210 Trasera	100 mm	45 mm	28 1/4"	4 3/8"	2 1/2"	RB-1353	N/A

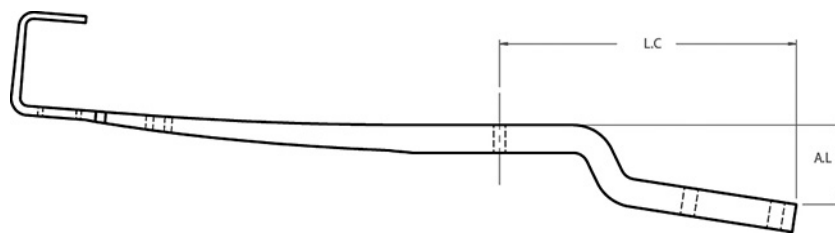

# SANDOVAL	# ORIGINAL	MODELO	ANCHO	ESPESOR	L./C.	L./L.	BRÍO	BUJE L.C	BUJE L.L
VW-0002-2	-	2 da Autobus 17210 Trasera	100 mm	45 mm	28 1/4"	19 3/8"	5"	N/A	N/A

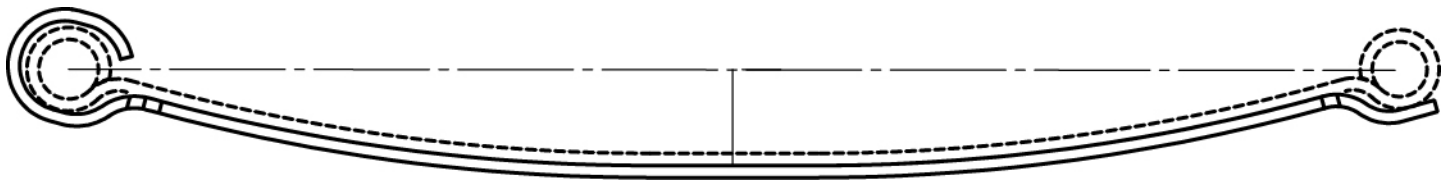

# SANDOVAL	# ORIGINAL	MODELO	ANCHO	ESPESOR	L./C.	L./L.	BRÍO	BUJE L.C	BUJE L.L
VW-0003-1	-	Vochobus	3"	0.499"	28 1/16"	28 1/16"	3 1/5"	63 mm	58 mm
VW-0003-2			3"	0.499	28 1/16	28 1/16	4"	-	-

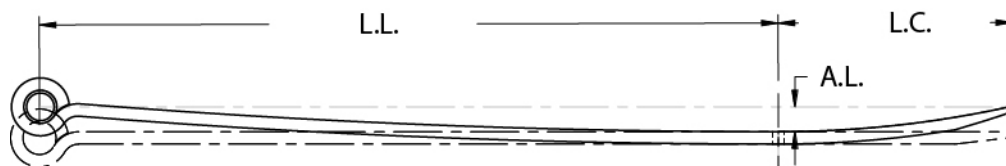

# SANDOVAL	# ORIGINAL	MODELO	ANCHO	ESPESOR	L./C.	L./L.	BRÍO	BUJE L.C	BUJE L.L
VW-0004-1	-	Tirante Worker trasera	3"	0.558"	33 1/2"	10 5/8"	1 1/8"	-	BB-RNG

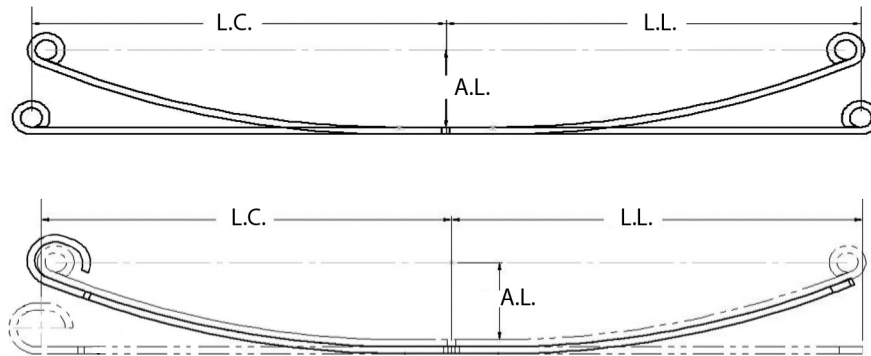

# SANDOVAL	# ORIGINAL	MODELO	ANCHO	ESPESOR	L./C.	L./L.	BRÍO	BUJE L.C	BUJE L.L
42026-VL	371010015	Withe 6000 Mod. 2000 / Delantera	4"	0.499"	26 1/2"	26 1/2"	5 1/2"		
42026-VL1				0.499"	26 1/2"	26 1/2"		PLK	PLK
42026-VL2				0.788"	26 1/2"	26 1/2"			

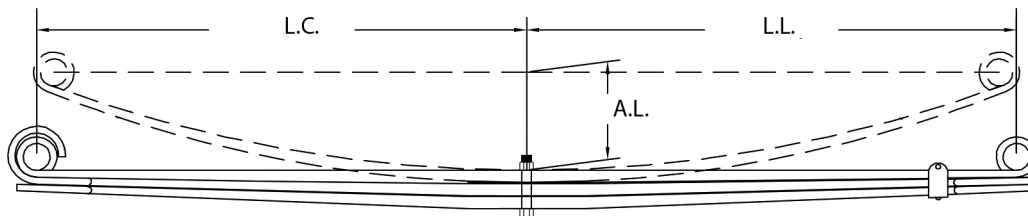

# SANDOVAL	# ORIGINAL	MODELO	ANCHO	ESPESOR	L./C.	L./L.	BRÍO	BUJE L.C	BUJE L.L
48025-V	-	Americano Mod. 89-00 / Delantera	4"	0.662"	25"	25"	-		
48025-V1				0.662"	25"	25"		PLK	PLK
48025-V2				0.662"	25"	26"			
48025-V3				0.662"	26"	26"			

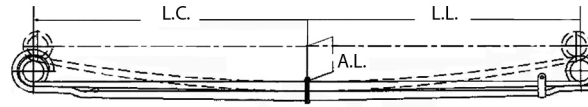

# SANDOVAL	# ORIGINAL	MODELO	ANCHO	ESPESOR	L./C.	L./L.	BRÍO	BUJE L./C	BUJE L./L
49835-V0	6790821, 6793913	Volvo FL6 / F6ZR Mod. 2004 / Delantera	100 mm	31 mm	35 7/16"	35 7/16"	4 1/2"		
49835-V01				31 mm	35 7/16"	35 7/16"			
49835-V02				31 mm	35 7/16"	37 3/8"			

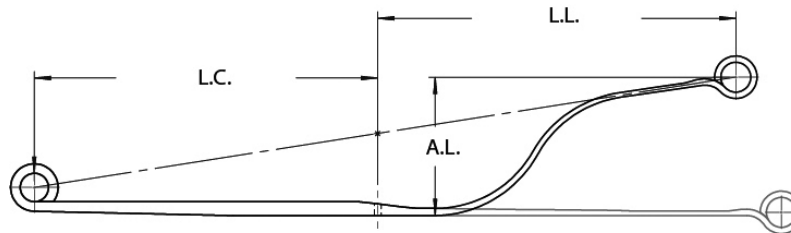

# SANDOVAL	# ORIGINAL	MODELO	ANCHO	ESPESOR	L./C.	L./L.	BRÍO	BUJE L./C	BUJE L./L
50032-VL	64772-000	Tractor Serie VN Mod. 97-00 / Delantera	4"	0.999"	27 5/16"	32 1/8"	5 3/8"	RB-233	RB-300

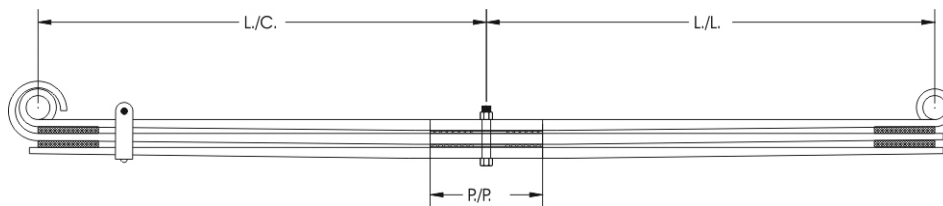

# SANDOVAL	# ORIGINAL	MODELO	ANCHO	ESPESOR	L./C.	L./L.	BRÍO	BUJE L./C	BUJE L./L
48026-V	371010036	Volvo 6000 Mod. 1997 / Delantera	4"	0.662"	26"	26"	4 1/2"		
48026-V1				0.662"	26"	26"		BM-PLK	BM-PLK
48026-V2				0.662"	26"	27"			
48026-V3				0.662"	27"	27"			

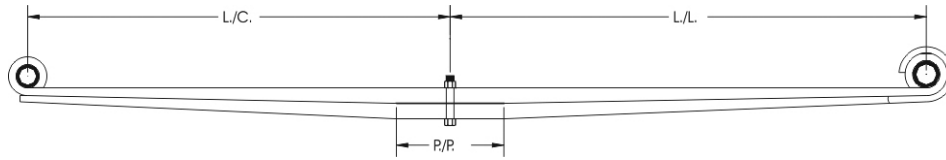

# SANDOVAL	# ORIGINAL	MODELO	ANCHO	ESPESOR	L./C.	L./L.	BRÍO	BUJE L./C	BUJE L./L
50027-V	257810	Tractor Serie VN Mod. 2001 / Delantera	4"	0.999"	27 1/2"	31"	4 3/4"		
50027-V1				0.999"	27 1/2"	31"		45 mm	45 mm
50027-V2				0.999"	28 1/2"	31"			

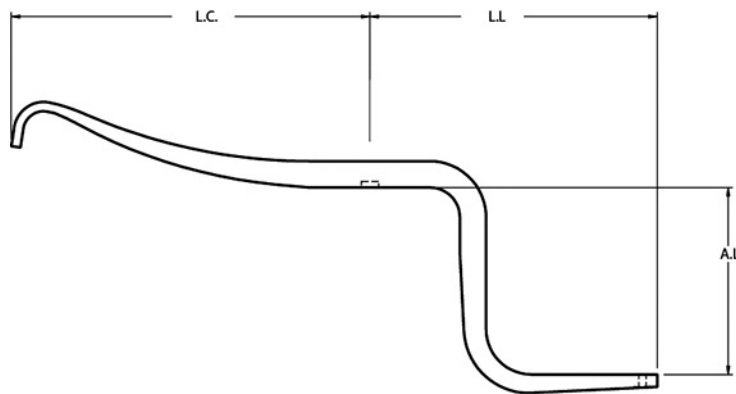

# SANDOVAL	# ORIGINAL	MODELO	ANCHO	ESPESOR	L./C.	L./L.	BRÍO	BUJE L./C	BUJE L./L
96-103	8065216	Tipo Zeta	3"	1.750"	23 3/4"	19 1/8"	N/A	N/A	N/A
96-1261	8180246		3"	1.750"	24 1/8"	19"	N/A	N/A	N/A
96-1301	8161834		3"	1.875"	23 3/4"	18 5/8"	N/A	N/A	N/A
96-1271	8086653		3"	1.750"	23 5/8"	19 3/8"	N/A	N/A	N/A

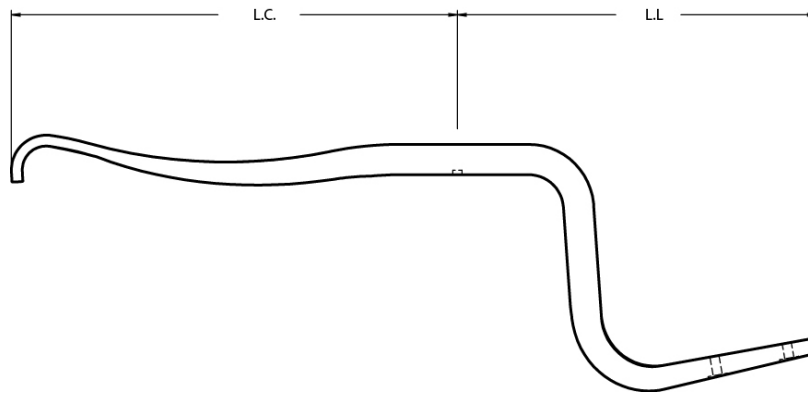

# SANDOVAL	# ORIGINAL	MODELO	ANCHO	ESPESOR	L./C.	L./L.	BRÍO	BUJE L./C	BUJE L./L
96-1273	8086647	Tipo Zeta	3"	1.750"	25 13/16"	20 5/8"	N/A	N/A	N/A

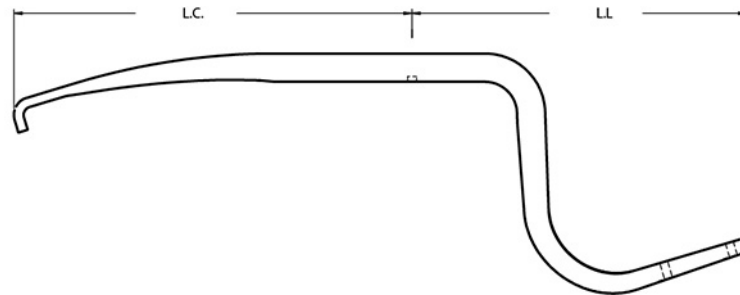

# SANDOVAL	# ORIGINAL	MODELO	ANCHO	ESPESOR	L./C.	L./L.	BRÍO	BUJE L./C	BUJE L./L
96-1319	20518808	Tipo Zeta Trasera	3"	1.750"	24 3/4"	20 3/4"	N/A	N/A	N/A

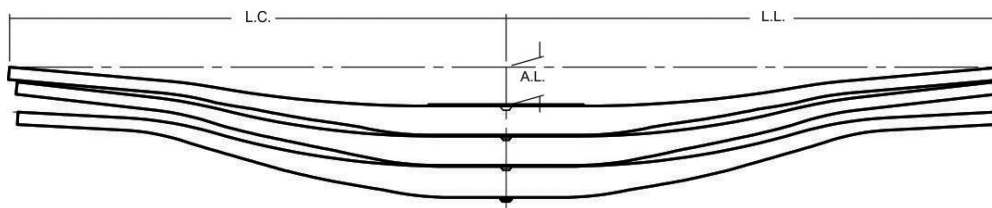

# SANDOVAL	# ORIGINAL	MODELO	ANCHO	ESPESOR	L./C.	L./L.	BRÍO	BUJE L./C	BUJE L./L
96-1307M	257900	White Mod. 2002-2006 / Trasera	3"	1.875"	32 1/4"	32 1/4"	2 1/2"		
96-1307M1				1.875"	32 1/4"	32 1/4"			
96-1307M2				2.000"	31 7/8"	31 7/8"			
96-1307M3				2.000"	31 7/8"	31 7/8"			

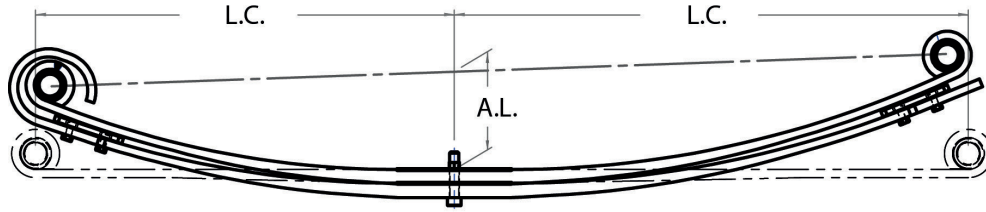

# SANDOVAL	# ORIGINAL	MODELO	ANCHO	ESPEJOR	L./C.	L./L.	BRÍO	BUJE L.C	BUJE L.L
96-1374	-	-	4"	0.788"	23 1/16"	28 5/16"	5 3/8"		
96-1374-1			4"	0.788"	23 1/16"	28 5/16"		TB-78 C/caja	TB-78 C/caja
96-1374-2			4"	0.788"	23 1/16"	29 3/4"			

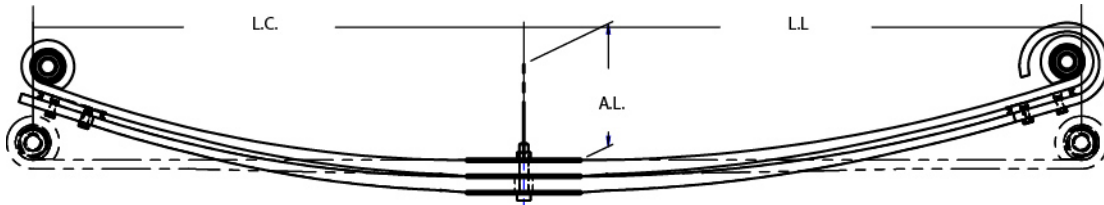

# SANDOVAL	# ORIGINAL	MODELO	ANCHO	ESPEJOR	L./C.	L./L.	BRÍO	BUJE L.C	BUJE L.L
	20789251	Volvo / GM	4"	0.905"	27 9/16"	31 5/16"	5.4"		
96-1384-1			4"	0.905"	27 9/16"	31 5/16"		RB-341	RB-341
96-1384-2			4"	0.905"	28 3/4"	31 5/16"			

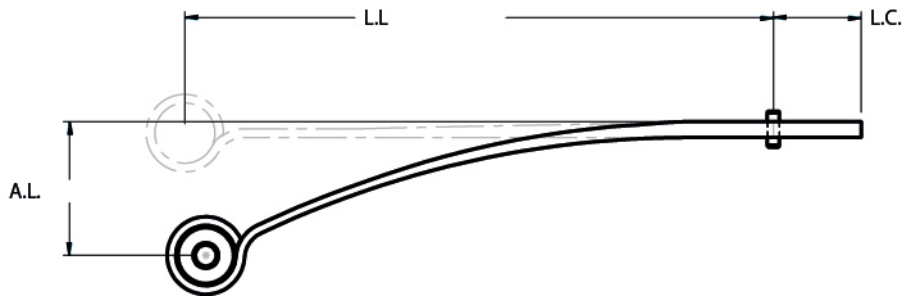

# SANDOVAL	# ORIGINAL	MODELO	ANCHO	ESPEJOR	L./C.	L./L.	BRÍO	BUJE L./C	BUJE L./L
96-1323	20521246	Tirante Air Suspension	3"	0.662"	24 1/2"	3 11/16"	5 9/16"	RB-290	N/A

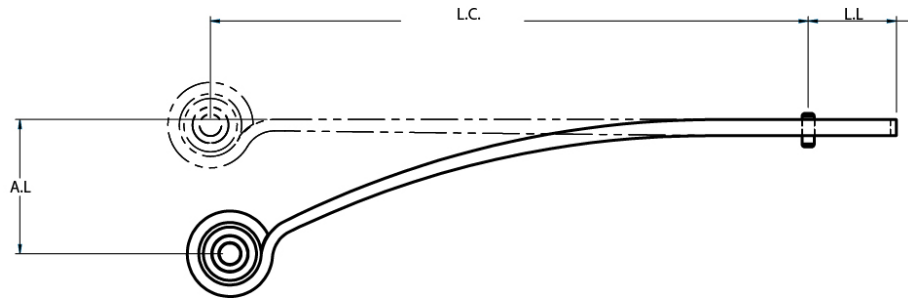

# SANDOVAL	# ORIGINAL	MODELO	ANCHO	ESPESOR	L./C.	L./L.	BRÍO	BUJE L./C	BUJE L./L
96-1333	20830477		3"	0.662"	24 9/16"	3 5/8"	5 1/2"	RB-290	N/A

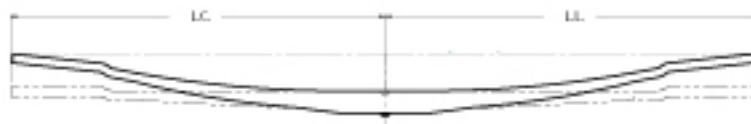

# SANDOVAL	# ORIGINAL	MODELO	ANCHO	ESPESOR	L./C.	L./L.	BRÍO	BUJE L./C	BUJE L./L
VL-0001-1	-	Volvo White 2005 (Trompo) Trasera	3"	0.662"	31 3/4"	31 3/4"	5 1/2"	NA	N/A

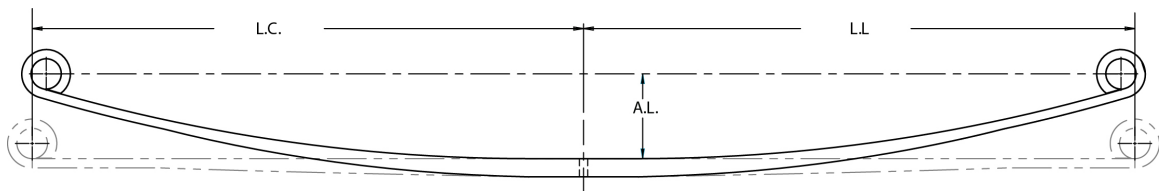

# SANDOVAL	# ORIGINAL	MODELO	ANCHO	ESPESOR	L./C.	L./L.	BRÍO	BUJE L./C	BUJE L./L
VL-0002	-	-	100 mm	30 mm	900 mm	900 mm	139.7 mm	50 mm	50 mm

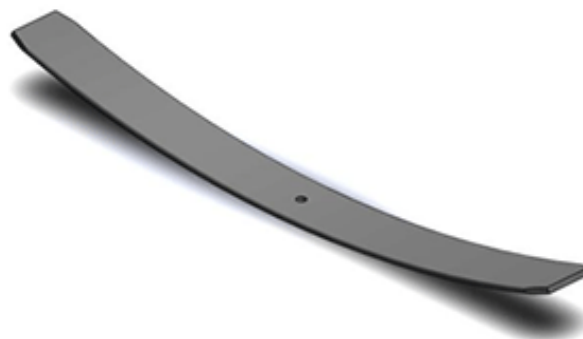

Hojas Lisas

# SANDOVAL	ANCHO	ESPESOR	L./C.	L./L.	BRÍO	DESCRIPCION
20317	2 1/4"	0.323"	17"	17"	3"	Extremos Despuntados
20319	2 1/4"	0.323"	19"	19"	3 1/4"	Extremos Despuntados
20321	2 1/4"	0.323"	21"	21"	4"	Extremos Despuntados
20323	2 1/4"	0.323"	23"	23"	4 1/2"	Extremos Despuntados
20326	2 1/4"	0.323"	26"	26"	5"	Extremos Despuntados
20328	2 1/4"	0.323"	28"	28"	5 3/4"	Extremos Despuntados
23319	2 1/2"	0.360"	19 1/2"	19 1/2"	3"	Extremos Despuntados
23321	2 1/2"	0.360"	21 1/2"	21 1/2"	4"	Extremos Cuadrados
23323	2 1/2"	0.360"	23 1/2"	23 1/2"	4 3/4"	Extremos Despuntados
23326	2 1/2"	0.360"	26"	26"	5"	Extremos Despuntados
23328	2 1/2"	0.360"	28"	28"	5 3/4"	Extremos Cuadrados
25319	2 1/2"	0.323"	19 1/2"	19 1/2"	3 1/2"	Extremos Despuntados
25321	2 1/2"	0.323"	21 1/2"	21 1/2"	4 1/4"	Extremos Despuntados
25323	2 1/2"	0.323"	23 1/2"	23 1/2"	4 3/4"	Extremos Despuntados
25326	2 1/2"	0.323"	26"	26"	5"	Extremos Cuadrados
25328	2 1/2"	0.323"	28 1/2"	28 1/2"	6"	Extremos Cuadrados
25330	2 1/2"	0.323"	30"	30"	6 1/2"	Extremos Despuntados
27326	2 1/2"	0.447"	26"	26"	5"	Extremos Despuntados
27328	2 1/2"	0.447"	28"	28"	5 3/4"	Extremos Cuadrados
27330	2 1/2"	0.447"	30"	30"	-	Extremos Cuadrados
32313	3"	0.449"	13"	13"	1 1/2"	Extremos Despuntados
32315	3"	0.449"	15"	15"	2"	Extremos Despuntados
32317	3"	0.449"	17"	17"	3"	Extremos Despuntados
32319	3"	0.449"	19"	19"	3 1/4"	Extremos Despuntados
32321	3"	0.449"	21"	21"	4"	Extremos Despuntados

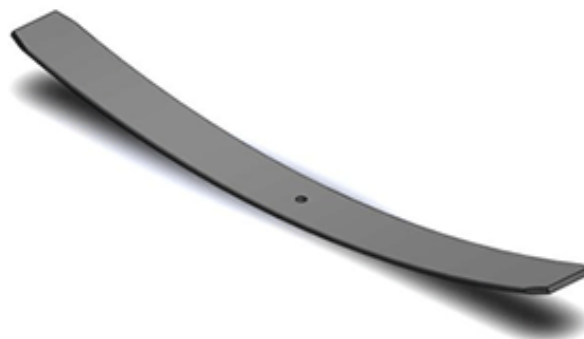

Hojas Lisas

# SANDOVAL	ANCHO	ESPESOR	L./C.	L./L.	BRÍO	DESCRIPCION
32322	3"	0.449"	22"	22"	4 3/8"	Extremos Cuadrados
32323	3"	0.449"	23"	23"	4 1/2"	Extremos Cuadrados
32324	3"	0.449"	24"	24"	4 1/2"	Extremos Despuntados
32326	3"	0.449"	26"	26"	5"	Extremos Cuadrados
32328	3"	0.449"	28 7/8"	28 7/8"	5 3/4"	Extremos Despuntados
32332	3"	0.449"	32"	32"	5 7/8"	Extremos Cuadrados
32526	3"	0.449"	22"	26"	5"	Extremos Cuadrados
33316	3"	0.360"	16 1/2"	16 1/2"	2 1/2"	Extremos Despuntados
33321	3"	0.360"	21"	21"	4"	Extremos Cuadrados
33323	3"	0.360"	23 1/2"	23 1/2"	4 1/2"	Extremos Despuntados
34325	3"	0.401"	25 1/2"	25 1/2"	5"	Extremos Despuntados
34328	3"	0.401"	28"	28"	5 3/4"	Extremos Cuadrados
40313	3 1/2"	0.401"	13"	13"	2"	Extremos Despuntados
42326	4"	0.499"	26"	26"	5"	Extremos Despuntados
42520	4"	0.499"	20"	22"	5"	Extremos Cuadrados
42522	4"	0.499"	17"	22"	Libre	Extremos Despuntados
42525	4"	0.499"	18"	25 1/2"	Libre	Extremos Despuntados
42526	4"	0.499"	23"	26"	4"	Extremos Despuntados
42525-LR	4"	0.499"	25"	28"	5"	Extremos Cuadrados
20323-MG	2 1/2"	0.323"	23 1/2"	23 1/2"	4 1/2"	Extremos Cuadrados

06	Astra	94	Isuzu
07	Chevrolet	98	Jeep
17	Chrysler	99	Kenworth
21	Dina	109	Lozano
32	Dodge	110	Mack
36	Famsa	111	MCM
37	Faw Trucks	114	Mercedes Benz
39	Ferbus	128	Mitsubishi
40	Fiat	131	Nissan
41	Ford	136	Peterbilt
55	Foton	140	Remolques
59	Freightliner	144	Reyco
70	Fruehauf	147	Tirantes
72	General Motors	148	Toyota
73	Hendrickson	155	Vilchis
77	Hino	157	Volkswagen
80	Hutchens	161	Volvo
81	Hyundai	167	Hojas Lisas
82	International		

54-144-01	77	22723-C	40, 41	28729-SP	114	32442-TR	147
55-1248	91	23016	141	28729-ST	115	32526	168
55-1516	92	23026-FL	42	28826-FD	43	32533-T	147
59-410-1	106	23030	7	28828-CH	13	32533-TDR	147
59-410-2	106	23032	8	28828-DG1	18	32534-T	147
75-128	136	23032-DG	32	28925-IZ	95	32534-TD	147
83-167	144	23127-SER	12	28925-IZM	95	32534-TDR	147
83-273	144	23319	167	28929-FG	115	32534-TR	147
90-297-2RD	154	23321	167	29025-NI	133	33019-A	44
96-1323	165	23323	167	29624-V	18	33026	20
17014-E	140	23326	167	30225-FD2RD	44	33028-VW	157
17123	98	23328	167	306037-MB1	115	33031-FD	45
18131-CV	21	24032	8	306037-MB2	116	33033-FD	45
18635-CV	99	24725-IZ	97	32021	70	33316	168
19822-B	148	24726-CG	37	32021-B	70	33321	168
19822-T	148	24726-IZ	94	32022-H	39	33323	168
19822-TY	148	24734M-MB	114	32023-L	109	34025-F	46
20022	131	24820-MSR	128	32028	111	34030	47
20023	131	25026	9	32028M	112	34030-B12	147
20024-TY	149	25026-CH1	10	32028-R	113	34030-B12R	147
20025-NI2RD	132	25026-CH2RD	10	32029-DG	19	34032-VW	157
20026	41	25026-FR	42	32029-DG2RD	20	34125-B	36
20317	167	25027-DG1	17	32030	21	34-1431-1	32
20319	167	25030	11	32030-DG	19	34-1431-2R	32
20321	167	25319	167	32038	22	34-1453-1	33
20323	167	25321	167	32038-14	147	34-1453-2RD	33
20323-MG	168	25323	167	32038-15R	147	34-1459-1	34
20326	167	25326	167	32125-LR	147	34-1459-2RD	34
20328	167	25328	167	32135-TF	147	34225-B	36
20722-TY	149	25330	167	32136-T	147	34325	168
20816-E	141	26026-C	43	32225-LR	147	34328	168
20822-NT1	132	27032-CH	12	32235-TFR	147	35125-FD	48
21026-C	11	27326	167	32313	167	35225-FD2RD	48
21124-E	17	27328	167	32315	167	36028-FD	47
21622-IZ	96	27330	167	32317	167	36030-F	59
21623-TY	150	27620-TY	151	32319	167	36038-MB	116
21722	150	27621-TY	152	32321	167	36122-TV	147
21722-TY	150	27827-IZ1	97	32322	168	36122-TVR	147
21725-NI	133	27827-IZ2	97	32323	168	36128-E	48
21729-TY	151	27920-DG	16, 17	32324	168	36228-E	48
22-1567-1	6, 7	27921-TY	152	32326	168	37028-CH	13
22-1801-1	72	27922-CG	38	32328	168	37036	23
22-1801-2R	72	27927-DG2RD	18	32332	168	37127-T	147

37127-TR 147	43-1265-2RD 50	49026-FL 66	701125-HI 78
37527-T 147	43-1289 50	49029-S 28	701534-MB 123
38019 73	43-1289HD-2RD 50	49032 102	702534-MB 123
38022-FL 60	43-1855 51	49125-IT 85	75-163 137
38030-FL 60	43-620 49	49128-P 67	75-167 107
38038-M 117	44026 101	49129-AQ 29	75-210 137
38926-F 61	44028 26	49132-K 103	75-212 138
38926-FG 61	44029 36	49225-I2 86	75-228 138
39023-K 99	44029-GR 121	49228-P 67	802129-HI1 78
39025-IN 82	45117 74	49232-K 103	83-167 144
39028-K 100	45217 74	49835-VO 162	90-287 153
39034-VW 158	46-1211 63	49928-KW1 103	90-297 153
39626-FL 62	46-1213 63	49928-KW2 103	96-103 163
39626HD-FL1 62	46-1302 64	50025-FL 67	96-1261 163
39633-FL 63	46-1345 64	50025-FLR 67	96-1271 163
39725-MB 73	46-1347 64	50025-IT 86	96-1273 164
39728-K 100	46-1434 65	50026-F 68	96-1301 163
39729-K 14	47025-GR 27	50027-V 163	96-1307M 164
39937-MB 117	47033-E 121	50029-IN 87	96-1319 164
40313 168	47033-M 122	50029-IT 87	96-1333 166
40509 82	47033M-M 122	50031 104	96-1374 165
40744-MB 118	47125-GR 27	50032 104	96-1384 165
41723-G 82	47128-P 65	50032-3R 105	AS-0001 6
41723-N 83	47225-GR 27	50032-KW 105	CG-0001 38
41723-NE 83	47228-P 65	50032-PT 136	CH-0002-1 15
42025-IN 84	48017-G 74	50032-VL 162	CH-0002-2RD 16
42025-K 14	48025-V 161	50117-E 68	CH-0004 16
42026-VL 161	48026 65	50-244 75	CR-0001 16
42028 24	48026-M 66	50-363 75	DG-0001 34, 35
42029-D 25	48026-V 162	50387Z 75	DG-0002-1 35
42029-V 25	48029 27	50389Z 75	DI-0001 29
42032M-MB 120	48029-RM 28	55-067 88	DI-0002 30
42032-MB 119	48125-FE 28	55067ZR 88	DI-0003 31
42035-VW 158	48127-KC 102	55-1133Z 88	FD-0004-1 52
42326 168	48227-KC 102	55-1180 89	FD-0005-1 52
42507-KW 101	48523-F 147	55-1216 90	FD-0006-1 53
42520 168	49024 155	55-1238 90	FD-0006-2 53
42522 168	49024-A 155	55-1256 89	FD-0007-1 54
42525 168	49024-B 156	55-900 89	FD-0010-1 54
42525-LR 168	49025-I 84	56-297-2 94	FI-0001-1 40
42526 168	49025M-IT 85	59-610 106	FL-0001 69
43028 26	49026-FE 102	62-023 110	FL-0002-1 69
43-1265-1 49	49026-FG 66	69-285 134	FL-0003 69

FN-0001	55	SW4	142
FN-0002-1	55	SW4-C	142
FN-0002-2	55	SW5	143
FN-0002-3	56	TRA-074	145
FN-0003-1	56	TRA-075	146
FN-0004	57	TRA-087	71
FN-0005	57	TRA-088	71
FN-0006	58	TRA2726	80
GM-0001-1	72	TRA2727	80
HE-0001	76	TRA2741	80
HHY-0001	81	TRA-3387	146
HHY-0002	81	TY-0002-2	154
HI-0001-1	79	VL-0001-1	166
HI-0001-2R	79	VL-0002	166
HI-0002-1	79	VW-0001-T	159
IT-0001	92	VW-0002-1	159
IT-0003	93	VW-0002-2	159
IT-0004-1	93	VW-0003-1	160
IT-0005	93	VW-0003-2	160
KW-0001	107	VW-0004-1	160
KW-0002	108		
KW-0003	108		
MB-0005	124		
MB-0006-1	125		
MB-0007	125		
MB-0008	125		
MB-0009	126		
MB-0010-1	126		
MB-0011-1	127		
MB-0011-3	127		
MK-0001-1	110		
MS-0001-1	128		
MS-0001-2R	129		
MS-0002-1	129		
MS-0002-2RD	129		
MS-0003	130		
NI-0001	134		
NI-0002-1	134		
NI-0003-1	135		
NI-0003-2RD	135		
NI-0005-1	135		
PT-0001	139		